

FM6320 User Manual

V1.25



Table of contents

1	INTRODUCTION	7
1.1	ATTENTION	7
1.2	INSTRUCTIONS OF SAFETY	8
1.3	LEGAL NOTICE	8
1.4	ABOUT DOCUMENT	8
2	BASIC DESCRIPTION	9
2.1	PACKAGE CONTENTS	9
2.2	BASIC CHARACTERISTICS	9
2.3	MECHANICAL FEATURES	10
2.4	TECHNICAL INFORMATION ABOUT INTERNAL BATTERY!	11
2.4.1	<i>Battery Disposal instructions:</i>	11
2.5	ELECTRICAL CHARACTERISTICS	12
2.6	ABSOLUTE MAXIMUM RATINGS	13
3	CONNECTION AND PINOUT	14
3.1	SIM CARD INSERT SCHEME	14
3.2	INSTALLING FM6320 DRIVERS	15
3.3	NAVIGATE LED	16
3.4	STATUS LED	17
3.5	SOCKET 2×10 PINOUT	17
3.6	USB	18
3.7	ACCESSORIES	18
4	FIRMWARE	25
4.1	UPDATING FIRMWARE USING USB CABLE	25
5	OPERATIONAL BASICS	26
5.1	OPERATIONAL PRINCIPLES	26
5.2	OPERATIONAL MODES	27
5.3	ACCELEROMETER	27
5.4	TOTAL ODOMETER	27
5.5	PROFILES	27
5.6	FEATURES	28
5.6.1	<i>Scenarios</i>	28
5.6.1.1	ECO driving/Green driving Scenario	28
5.6.1.2	Over Speeding Scenario	28
5.6.1.3	Authorized Driving and Immobilizer Scenario	28
5.6.1.4	iButton notification	28
5.6.1.5	Excessive idling	29
5.6.1.6	Jamming detection	29
5.6.1.7	Crash detection	29
5.6.2	<i>Trip</i>	29
5.6.3	<i>Geofencing</i>	29
5.6.4	<i>Auto Geofencing</i>	29
5.6.5	<i>iButton list</i>	29
6	CONFIGURATOR	30
6.1	STARTUP	30
6.2	CONFIGURATOR STRUCTURE	30
6.2.1	<i>Buttons area</i>	31
6.2.2	<i>Information area</i>	31
6.2.3	<i>Profiles/global parameters selection area</i>	32
6.3	PARAMETERS CONFIGURATION	32
6.3.1	<i>Global parameters Settings</i>	32
6.3.2	<i>External Devices Settings</i>	34

6.3.3	<i>Settings and configurable parameters menu</i>	35
6.3.4	<i>System Settings</i>	35
6.3.5	<i>GSM Settings</i>	36
6.3.5.1	GPRS.....	36
6.3.5.2	Data limits functionality	36
6.3.5.3	SMS Security.....	37
6.3.5.4	SMS Data.....	37
6.3.5.5	SMS Events.....	38
6.3.5.6	Operator List	39
6.3.6	<i>Features</i>	40
6.3.6.1	sMode	40
6.3.6.2	Scenarios	41
6.3.6.3	Trip.....	42
6.3.6.4	Geofencing	43
6.3.6.5	AutoGeofencing	44
6.3.6.6	iButton List.....	45
6.3.7	<i>CAN</i>	46
6.3.7.1	CAN interface parameters.....	46
6.3.8	<i>I/O</i>	49
6.3.8.1	FM6320 available I/O list.....	49
6.3.8.2	I/O configuring	52
6.3.8.3	I/O properties.....	54
6.3.8.4	K Line parameters	56
6.3.8.5	Configurable parameter values and Global parameter values.....	59
7	PROFILE SWITCHING	66
7.1	PROFILE SWITCHING DEPENDENCE ON GSM OPERATOR	67
7.2	PROFILE SWITCHING DEPENDENCE ON I/O EVENT	69
7.2.1	<i>Example #1</i>	69
7.2.2	<i>Example #2</i>	69
8	DUAL SIM FUNCTIONALITY	70
8.1.1	<i>Home Network</i>	71
8.1.2	<i>SIM 1 Roaming</i>	71
8.1.3	<i>SIM 2 Roaming</i>	72
8.1.4	<i>Unknown Operator</i>	73
8.1.5	<i>Dual SIM algorithm</i>	75
9	DATA ACQUISITION	76
9.1	GPS DATA ACQUISITION	76
9.1.1	<i>Min. Period</i>	77
9.1.2	<i>Min. Distance</i>	77
9.1.3	<i>Min. Angle</i>	77
9.1.4	<i>Min. Speed</i>	78
9.2	I/O DATA ACQUISITION	78
9.2.1	<i>Configuration</i>	78
9.2.2	<i>Event generation</i>	78
10	SLEEP MODE	79
11	DEEP SLEEP MODE	80
12	FEATURES AND SCENARIOS	81
12.1	ECO DRIVING/GREEN DRIVING SCENARIOS	81
12.1.1	<i>Mounting Requirements</i>	82
12.1.2	<i>Configuration</i>	84
12.1.3	<i>Data output</i>	84
12.2	OVERSPEEDING SCENARIO	85
12.2.1	<i>Mounting Requirements and Working Conditions</i>	85
12.2.2	<i>Configuration</i>	85
12.3	IMMOBILIZER/ AUTHORIZED DRIVING SCENARIO	85

12.3.1	Configuration.....	86
12.3.2	Configuration.....	86
12.4	EXCESSIVE IDLING SCENARIO	87
12.5	JAMMING DETECTION SCENARIO.....	87
12.5.1	Configuration.....	87
12.6	IBUTTON NOTIFICATION SCENARIO.....	87
12.6.1	Configuraton.....	88
12.7	CRASH DETECTION SCENARIO	88
12.7.1	Configuration.....	88
12.8	COM1 AND COM2 WORKING MODES	88
12.8.1	Silent Mode.....	88
12.8.2	FM Log Mode.....	88
12.8.3	LLS Mode	88
12.8.3.1	LLS Mode Configuration	88
12.8.4	LCD Mode Configuration	89
12.8.5	RFID HID Mode Configuration	89
12.8.6	RFID MF7 Mode Configuration	89
12.8.7	Garmin Mode Configuration.....	89
12.8.7.1	Settings.....	89
12.8.7.2	Firmware Configuration	89
12.8.8	TCP Link Mode	90
12.8.9	TCP Link Mode (Binary).....	90
12.8.10	NMEA Log Mode.....	91
12.8.11	Records to LCD mode.....	91
13	SMS COMMAND LIST	91
13.1	GETSTATUS	93
13.2	GETWEEKTIME	93
13.3	GETOPS	93
13.4	READOPS	94
13.5	GETNMEAINFO.....	94
13.6	GETCFGTIME	94
13.7	GETGPS	94
13.8	LOADPROFILE#	95
13.9	CPURESET	95
13.10	RESETALLPROF	95
13.11	GETVER	95
13.12	GETIO.....	95
13.13	GETINFO	95
13.14	DELETERECORDS.....	96
13.15	READIO #.....	96
13.16	SETDIGOUT ##### X Y Z W.....	96
13.17	GETPARAM #####	96
13.18	SETPARAM ##### #	97
13.19	FLUSH #,#,#,#,#,##	97
13.20	GETGNSS	98
13.21	SN X.....	98
13.22	BANLIST.....	98
13.23	CRASHLOG	99
13.24	BRAMINFO	99
13.25	ODINFO	99
14	FM6320 WITH LV-CAN 200 AND ALL-CAN 300 CAN ADAPTER	100
14.1	PURPOSE OF CAN ADAPTERS LV-CAN200 AND ALL-CAN300	100
14.2	LV-CAN200 AND ALL-CAN300 PROGRAM NUMBER SELECTION	100
14.2.1	LV-CAN200 and ALL-CAN300 program number configuration via SMS command.....	100
14.2.2	Selecting LV-CAN200 and ALL-CAN300 program number manually	101
14.2.3	Program number logic change	101

14.3	SIMPLE-CAN - CONTACTLESS CAN-BUS READER	102
14.4	CONNECTING FM6320 CAN ADAPTERS ALL-CAN300 AND LV-CAN200	103
14.5	FM 6320 CONFIGURATON	104
15	CAN	106
15.1	GENERAL DESCRIPTION	107
15.2	CONFIGURATION	107
15.3	EXAMPLE	108
15.4	FM6300J1708 CONNECTION	111
15.5	SOFTWARE CONFIGURATION OF FM6300 WITHJ1708	112
15.6	AUTOCAN DESCRIPTION	114
15.6.1	<i>Configuration</i>	114
15.6.2	<i>CAN monitoring</i>	115
15.6.3	<i>Offline configuration</i>	116
15.6.4	<i>AutoCAN ID list</i>	116
15.7	AUTOCAN CONFIGURATION OVER SMS	130
15.7.1	<i>SMS command format</i>	130
15.7.2	<i>AutoCAN element Id's</i>	131
16	USING TACHOGRAPH	132
16.1	CONNECTING TO TACHOGRAPH	132
16.2	TACHO WEB	135
16.3	TACHOCHECK SMS	136
17	RS485 INTERFACE	136
17.1	RS485 MODES	136
17.1.1	<i>RS485 Receive (Silent) Mode</i>	137
17.1.2	<i>RS485 Receive (TCP Link) Mode</i>	137
17.1.3	<i>RS485 Receive (LLS) Mode</i>	138
17.1.4	<i>RS485 Transmit (FM Log) Mode</i>	138
17.1.5	<i>RS485 Transmit (GPS Nmea) Mode</i>	138
17.1.6	<i>RS485 Self-Test Mode</i>	138
17.2	RS485 INTERFACE	139
18	RFID	139
19	GARMIN	140
19.1	SUPPORTED GARMIN FMI PROTOCOLS	141
19.1.1	<i>Standard protocols</i>	141
19.1.2	<i>Enhanced protocols</i>	142
19.2	SUPPORTED FEATURES ON TAVL CLIENT APPLICATION	142
19.3	TEXT MESSAGING	142
19.4	DESTINATION MESSAGE	142
19.5	ETA REQUEST MESSAGE	143
19.6	CONNECTION AND PINOUT	143
20	LLS SENSOR	144
20.1	SPECIFICATIONS	145
20.2	HARDWARE	145
20.3	CONNECTING LLS TO FM6320	145
21	MVC300 CAMERA	146
21.1	INTRODUCTION	146
21.2	STARTUP AND CONFIGURATION	146
21.2.1	<i>Camera parameters in FM6320</i>	148
21.2.2	<i>Camera parameters in MVC300</i>	148
21.3	FM6320 AND MVC300 CONNECTION	149
22	GPRS COMMANDS	149

23	DEBUG MODE.....	151
24	FM6320 REMOTE LOG	152
	MOUNTING RECOMMENDATIONS	155
24.1	CONNECTING WIRES.....	155
24.2	CONNECTING POWER SOURCE.....	155
24.3	CONNECTING IGNITION WIRE	155
24.4	CONNECTING GROUND WIRE	155
24.5	CONNECTING ANTENNAS.....	156
24.6	MODULE INSTALLATION	156
25	CHANGE LOG	157

1 INTRODUCTION

1.1 Attention



Do not disassemble the device. If the device is damaged, the power supply cables are not isolated or the isolation is damaged, before unplugging the power supply, do not touch the device.



All wireless data transferring devices produce interference that may affect other devices which are placed nearby.



The device must be connected only by qualified personnel.



The device must be firmly fastened in the predefined location.



The programming must be performed using a second class PC (with autonomic power supply).



The device is susceptible to water and humidity.



Any installation and/or handling during a lightning storm are prohibited.



FM6320 has USB interface;
Please use cables provided with FM6320 device.
Teltonika is not responsible for any harm caused by using wrong cables for PC <-> FM6320 connection.



This sign on the packaging means that the electric and electronic equipment to be utilized must be stored separately.

1.2 Instructions of safety

This chapter contains information on how to operate FM6320 safely. By following these requirements and recommendations, you will avoid dangerous situations. You must read these instructions carefully and follow them strictly before operating the device!

To avoid mechanical damage, it is advised to transport the FM6320 device in an impact-proof package. Before usage, the device should be placed so that its LED indicators are visible, which show the status of operation the device is in.

When connecting the connection (2x10) cables to the vehicle, the appropriate jumpers of the power supply of the vehicle should be disconnected.

Before dismounting the device from the vehicle, the 2x10 connection must be disconnected.

The device is designed to be mounted in a zone of limited access, which is inaccessible for the operator. All related devices must meet the requirements of standard EN 60950-1.

The device FM6320 is not designed as a navigational device for boats.

1.3 Legal Notice

Copyright © 2014 Teltonika. All rights reserved. Reproduction, transfer, distribution or storage of part or all of the contents in this document in any form without the prior written permission of Teltonika is prohibited.

Garmin and the Garmin logo are registered trademarks, all rights reserved.

Other products and company names mentioned here may be trademarks or trade names of their respective owners.

1.4 About document

This document contains information about the architecture, possibilities, mechanical characteristics, and configuration of the FM6320 device.

Acronyms and terms used in document:

PC – Personal Computer

GPRS – General Packet Radio Service

GPS – Global Positioning System

GSM – Global System for Mobile Communications

SMS – Short Message Service

AC/DC – Alternating Current/Direct Current

I/O – Input/Output.

Record – AVL data stored in FM6320 memory. AVL data contains GPS and I/O information

AVL packet - Data packet that is being sent to server during data transmission. AVL packet contains from 1 to 50 records.

Geofence – a virtual geographic area of interest that can be defined by a radius or polygon for the location. In this document term “Geofence” is often used as functionality, which generates an event when crossing a defined area.

2 BASIC DESCRIPTION

FM6320 is a terminal with GPS and GSM/3G connectivity, which is able to determine the object's coordinates and transfer them via the GSM/3G network. This device is perfectly suitable for applications, which need location acquirement of remote objects. It is important to mention that FM6320 has additional inputs and outputs, which let you control and monitor other devices on remote objects. FM6320 also has a USB port for device status log output and entering configurations.

2.1 Package contents¹

Usually the FM6320 device sample is supplied to the customer in a cardboard box containing all the equipment that is necessary for operation. The package contains:

FM6320 device

Input and output power supply cable with 2x10 connection pins

4 screws for assembling device

GPS/GLONASS antenna

GSM antenna

USB cable

Port 1/2 cable

Port 3 cable

2.2 Basic characteristics

GSM/GPRS/3G features:

- Telit HE910-GL 5-band module (GSM 850 / 900 / 1700 / 1900 / 2100 MHz);
- EGPRS class 33;
- SMS (text, data).

GNSS TG3300 Module features:

- Navigation Systems; GPS/GLONASS;
- Protocol NMEA-0183: GGA, GGL, GSA, GSV, RMC, VTG;
- Up to -162 dBm sensitivity.

Hardware features:

- STM32 processor;
- 1 MB internal Flash memory;
- External memory card slot;
- Built-in accelerometer.
- Internal backup battery included

Interface features:

- Power supply: 10 ÷ 30V;
- USB port;
- 4 digital inputs;
- 3 analog inputs;
- 4 open collector digital outputs;
- 4 1Wire[®] temperature sensor;

¹ Package content depends on Order Code, and can be customized by customer needs.

- 1Wire® iButton;
- LEDs indicating device status;
- K-Line interface for online Tachograph Vehicle Data transfer;
- 2xRS232 port;
- RS485 port;
- J1708 interface;
- LVCAN interface;
- CAN messages 2.0 A, B Active support. Speed up to 1 Mbit/s.
- Roaming enabling/disabling;
- Offline working mode;
- Records importing using USB/microSD card;
- Remote logs reading via SMS/GPRS;

Overvoltage protection (Devices with order code FM6320 Vxxxxx):

Table 1 Overvoltage Protecton:

Description	Voltage	Duration
Normal operation	10-30V	Unlimited
Protection turns on, device turns off.	34V	Unlimited
Maximum voltage	<70V	Unlimited
Maximum voltage impulse	90V	5 milliseconds

2.3 Mechanical features

Table 2 FM6320 physical interfaces and operation environment

Part name	Physical specification	Operation environment
Navigation LED	LED	Power supply 10...30 V DC 2 W Max Operation temperature: -25°C ... +55°C Storage temperature: -40°C ... +70°C Energy consumption ¹ : GPRS: --- 120 mA r.m.s Max., Nominal: --- average 65 mA r.m.s, GPS Sleep: --- average 28 mA, Deep Sleep: --- average less than 7 mA ² Storage relative humidity 5 ... 95 % (non condensating) Battery charge current: --- average 100 mA, Rated current: --- 250 mA, Internal fuse: 3A, 125V
Modem LED	LED	
GPS	GPS antenna connector SMA jack(female outer shell, female inner pin)	
GSM	GSM antenna connector RP-SMA jack(female outer shell, male inner pin)	
Socket 2x10	Tyco Micro MATE-N-LOK™ or similar	
USB	Mini USB socket	
Port1	RS232 and RS485 port channel 1 (RJ45 socket)	
Port2	RS232 port channel 1 (RJ45 socket)	
J1708	J1708 port channel	

¹ Energy consumption has been tested at 12V voltage with no battery charging.

²When in Deep Sleep mode no data storing and sending is activated.

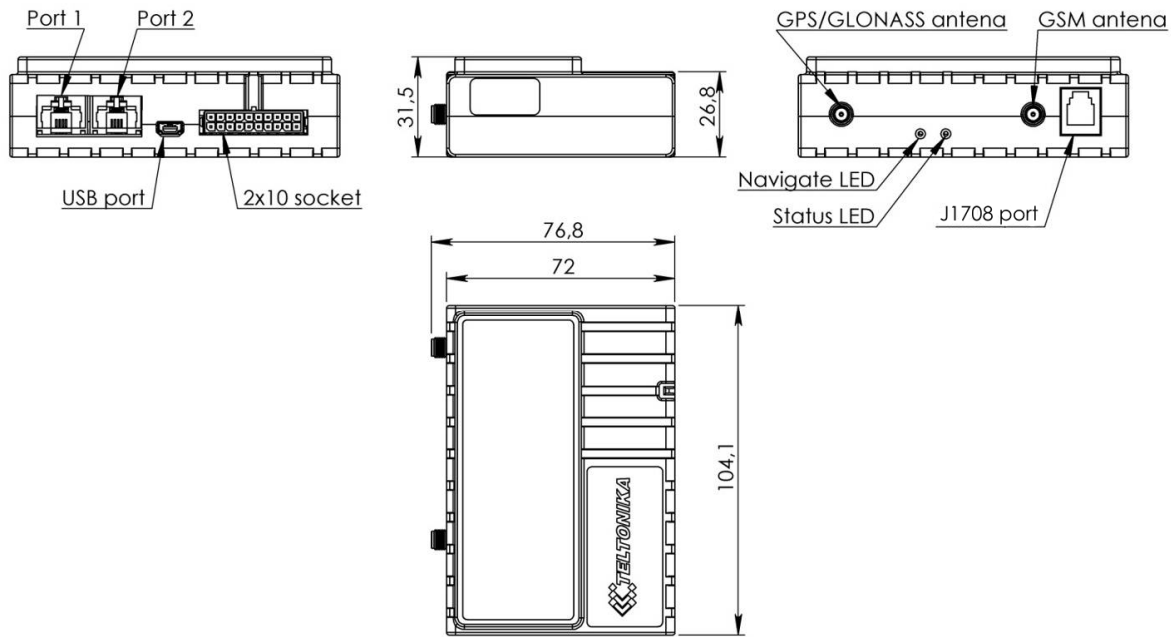

Figure 1 FM6320 view & dimensions in mm (tolerance ± 2 mm)

2.4 Technical Information about internal battery!

Ni-MH Rechargeable battery, 8.4V, 550 mA.

FM6320 operating time with internal backup battery depends on temperature, data sending frequency (SMS and GPRS), and accumulator age, number of charge/discharge cycles.

For example:

- In sleep mode a new FM6320 device, operating time approximately 5 hours
- In deep sleep mode – 35 hours
- Operating time for a new FM6320 device, working in normal mode (records are being acquired every 10 sec. and sent in packets of 4 records every 60 sec.), is approximately 2 h 10 min.
- Charging temperature: 0 – 40 °C



CAUTION: RISK OF EXPLOSION IF BATTERY IS REPLACED BY AN INCORRECT TYPE. DISPOSE OF USED BATTERIES ACCORDING TO THE INSTRUCTIONS.

2.4.1 Battery Disposal instructions:



Battery should not be disposed of with general household waste. Bring damaged or worn-out batteries to your local recycling center or dispose them to battery recycle bin found in stores.

2.5 Electrical characteristics

Table 3 Electrical characteristics

CHARACTERISTIC DESCRIPTION	VALUE	Min.	Typ.	Max.	Unit
	SUPPLY VOLTAGE				
Supply Voltage (Recommended Operating Conditions)	11.8	-	-	30	V
Supply Voltage (for internal rechargeable battery charging proper functioning)	11.8	-	-	30	V
POWER SUPPLY CURRENT (HARDWARE VERSION WITH INTERNAL BATTERY)					
Deep Sleep, average, I _{cc.ds}	-	2.5	4	-	mA
Sleep, average, I _{cc.ds} , V _{cc} =12V	-	45	-	-	mA
Sleep, average, I _{cc.ds} , V _{cc} =24V	-	25	-	-	mA
U _{cc} =12.6V, all modules fully working, internal battery is charging, I _{cc1}	-	-	-	350	mA
U _{cc} =12.6V, all modules fully working, internal battery is charged, I _{cc2}	-	-	-	300	mA
U _{cc} =25.2V, all modules fully working, internal battery is charging, I _{cc3}	-	-	-	195	mA
U _{cc} =25.2V, all modules fully working, internal battery is charged, I _{cc4}	-	-	-	140	mA
DIGITAL OUTPUT (OPEN DRAIN GRADE)					
Drain current (Digital Output OFF)	-	-	-	120	uA
Drain current (Digital Output ON, Recommended Operating Conditions)	-	-	-	300	mA
Static Drain-Source resistance (Digital Output ON)	-	-	-	300	mOhm
DIGITAL INPUTS					
Input resistance (DIN1, DIN2, DIN3)	15	-	-	-	kOhm
Input Voltage (Recommended Operating Conditions)	0	-	-	Supply voltage	V
Input Voltage threshold (DIN1)	-	7,5	-	-	V
Input Voltage threshold (DIN2, DIN3, DIN4)	-	2,5	-	-	V
ANALOG INPUTS					
Input Voltage (Recommended Operating Conditions), Range1	0	-	-	10	V
Input resistance, Range1	-	120	-	-	kOhm
Input Voltage (Recommended Operating Conditions) Range2	0	-	-	30	V

CHARACTERISTIC DESCRIPTION	VALUE			
	Min.	Typ.	Max.	Unit
Input resistance, Range2	-	147	-	kOhm
OUTPUT SUPPLY VOLTAGE 1-WIRE³				
Supply Voltage	3,3	-	3,9	V
Output inner resistance	-	7	-	Ohm
Output current ($U_{out} > 3.0V$)	-	30	-	mA
Short circuit current ($U_{out} = 0$)	-	130	-	mA
CAN INTERFACE				
Internal terminal resistors CAN bus	-	120	-	Ohm
Differential input resistance	19	30	52	kOhm
Recessive output voltage	2	2.5	3	V
Differential receiver threshold Voltage	0.5	0.7	0.9	V
Common mode input voltage	-30	-	30	V



When connecting a COM port to an active external device keep in mind that the first power supply must be connected to FM6320, and then the external device should be powered. Connecting external devices when FM6320 is powered off is not recommended.

2.6 Absolute Maximum Ratings

Table 4 Absolute maximum ratings

CHARACTERISTIC DESCRIPTION	VALUE			
	Min.	Typ.	Max.	Unit
Supply Voltage (Absolute Maximum Ratings)	-32		32	V
Digital output clamp threshold voltage (Absolute Maximum Ratings), ($I_{drain} = 2mA$)	36			V
Digital Input Voltage (Absolute Maximum Ratings)	-32		32	V
Analog Input Voltage (Absolute Maximum Ratings)	-32		32	V
Voltage on Supply Voltage 1-Wire (Absolute Maximum Ratings)	0		10	V
Voltage on Data Input/Output 1-Wire (Absolute Maximum Ratings)	0		10	V
Voltage on CANH, CANL (Absolute Maximum Ratings)	-58		58	V

³ 1-wire Supply voltage PIN is dedicated for 1-wire devices ONLY, do not use it for any other purpose.

3 CONNECTION AND PINOUT

3.1 SIM card insert scheme

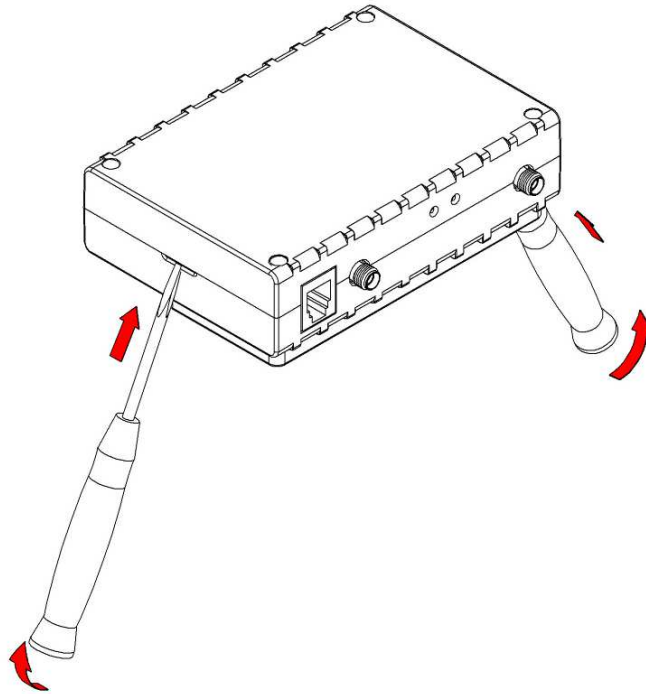

①

Gently open FM6320 case using screwdrivers

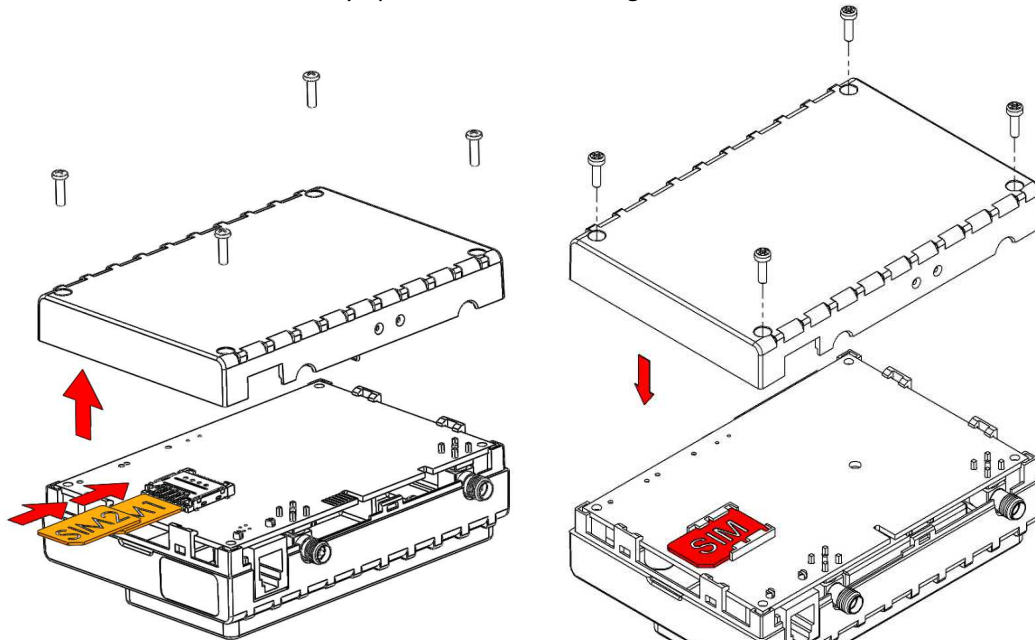

②

Take off FM6320 case and insert SIM cards as shown. SIM1 SLOT (default, recommended for 1 SIM mode) is closer to PCB, SIM2 SLOT is the upper one

③

Assemble device as shown and put screws into the holes

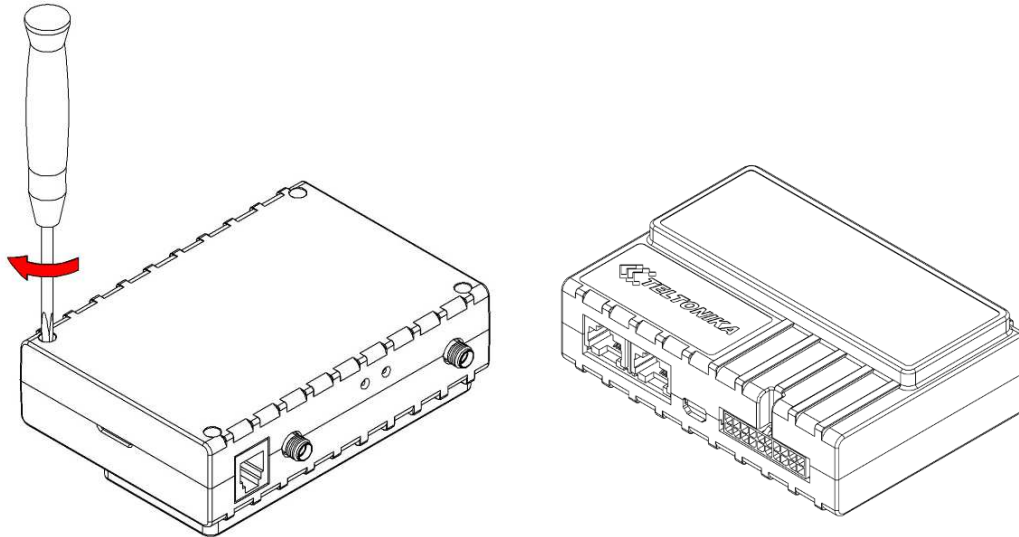

④

Screw all 4 screws

⑤

Device is ready

3.2 Installing FM6320 drivers

Software requirements

- Operating system 32-bit and 64-bit: XP with SP3 or later, Windows Vista, Windows 7, 8 and 10.
- MS .NET Framework V3.5 or later ([Microsoft](http://Microsoft.com))

Drivers

Please download Virtual COM Port drivers from Teltonika website: [FM6320 VCP Driver](#)

Installing drivers

Extract and run VCPDriver_V1.3.1_Setup.exe. This driver is used to detect FM6320 device connected to the computer. Click 'Next' in driver installation window (figures below):

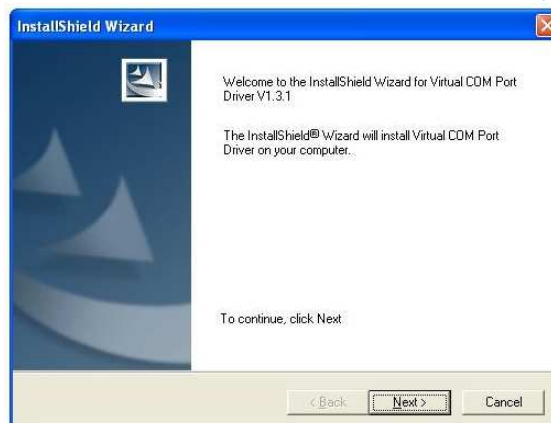

Figure 2 Driver installation window

This will launch the device driver installation wizard. In the following window click 'Next' button again:



Figure 3 Driver installation window

Setup will continue installing drivers and will display a window about successful process in the end. Click 'Finish' to complete setup:



Figure 4 Driver installation window

You have now installed drivers for FM6320 device successfully.

3.3 Navigate LED

Table 5 Navigate LED operation

Behaviour	Meaning
Permanently switched on	GPS signal is not received
Blinking every second	Normal mode, GPS is working
Off	GPS is turned off because: <ul style="list-style-type: none"> • Deep sleep mode Or <ul style="list-style-type: none"> • GPS antenna short circuited

3.4 Status LED

Table 6 Status LED Operation

Behaviour	Meaning
Blinking every second	Normal mode
Blinking every 2 seconds	Deep sleep mode
Blinking fast for a short time	Modem activity
Blinking fast constantly	Boot mode
Off	<ul style="list-style-type: none"> • Device is not working Or <ul style="list-style-type: none"> • Device firmware being flashed

3.5 Socket 2x10 pinout

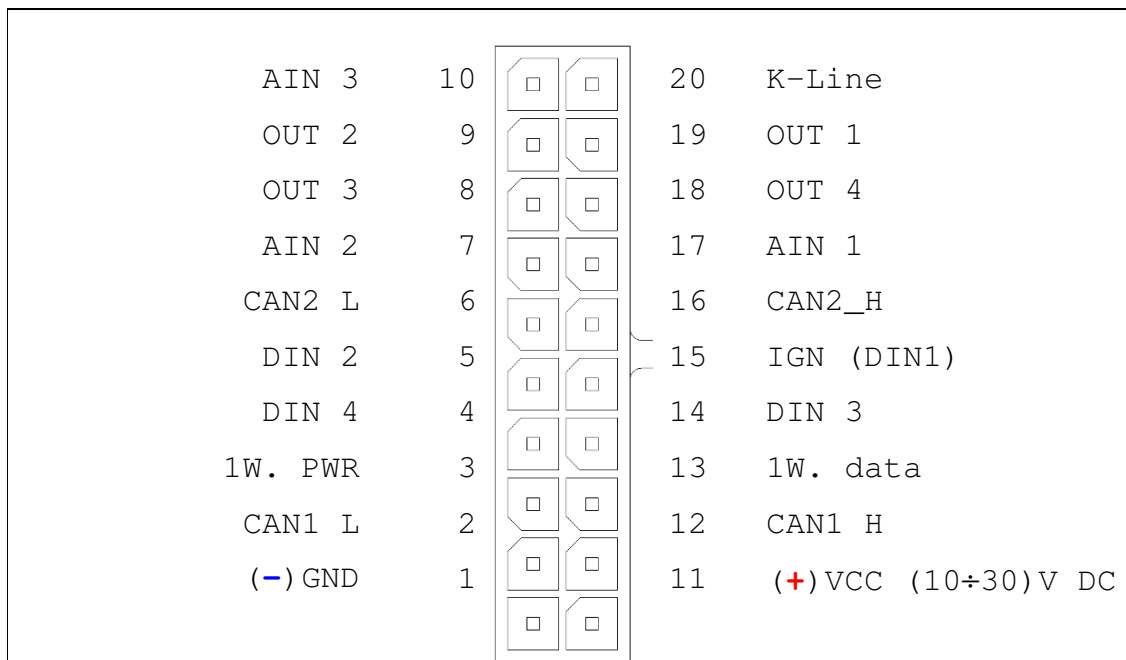

Figure 5 2x10 socket pinou

Table 7 2x10 SOCKET PINOUT DESCRIPTION

Pin Nr.	Pin Name	Description
1	(-)GND	(-) Ground pin. (10...30) V DC
2	CAN1 L	SAE J1939 CAN interface Low channel 1
3	1W. PWR	Power supply pin for Dallas 1-Wire® devices
4	DIN 4	Digital input. Channel 4
5	DIN 2	Digital input. Channel 2
6	CAN2 L	SAE J1939 CAN interface Low channel 2
7	AIN 2	Analog input, channel 2. Input range: 0 - 30V/ 0 - 10V DC
8	OUT 3	Digital output. Channel 3. Open collector output
9	OUT 2	Digital output. Channel 2. Open collector output
10	AIN 3	Analog input, channel 3. Input range: 0 - 30V/ 0 - 10V DC
11	(+)VCC (10...30) V DC	(+) Power supply pin (10...30) V DC
12	CAN1 H	SAE J1939 CAN interface High channel 1
13	1W. data	Data channel for Dallas 1-Wire® devices
14	DIN 3	Digital input, channel 3
15	DIN 1	Digital input, channel 1 (RESERVED FOR IGNITION LINE)
16	CAN2 H	SAE J1939 CAN interface High channel 2
17	AIN 1	Analog input, channel 1. Input range: 0 - 30V/ 0 - 10V DC
18	OUT 4	Digital output. Channel 4. Open collector output
19	OUT 1	Digital output. Channel 1. Open collector output
20	K-LINE	K-LINE interface for online Tachograph Vehicle Data transfer

3.6 USB

When FM6320 is connected to a PC it creates a STM Virtual COM Port, which can be used as a system port (to flash firmware and configure the device).

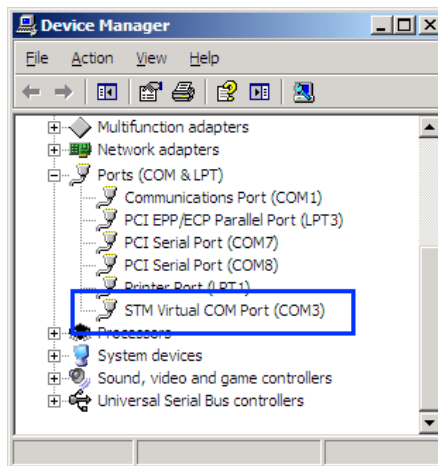

Figure 6 COM-Ports

3.7 Accessories



Note: Teltonika does not provide any additional equipment like panic buttons, door sensors etc, except 1 – wire devices: TTJ-101 thermo sensor, I-Button, 1-

wire RFID. These devices are not included in FM6320 package and can be offered by special order only.

1 – Wire devices

One of the FM6320 features is realized 1-Wire data protocol, which enables connection of up to three different type thermometers (DS1820, DS18S20 and DS18B20) and I-Button [DS1990A](#). Figure 7 and Figure 9 shows FM6320 and 1-wire devices connection schemes.

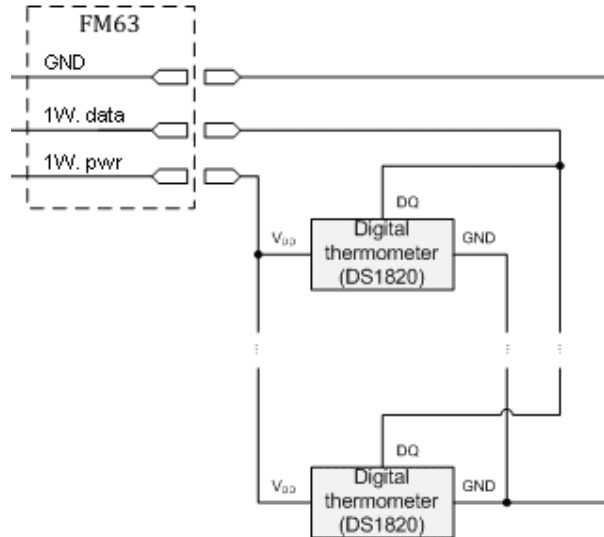

Figure 7 Temperature sensors connection scheme

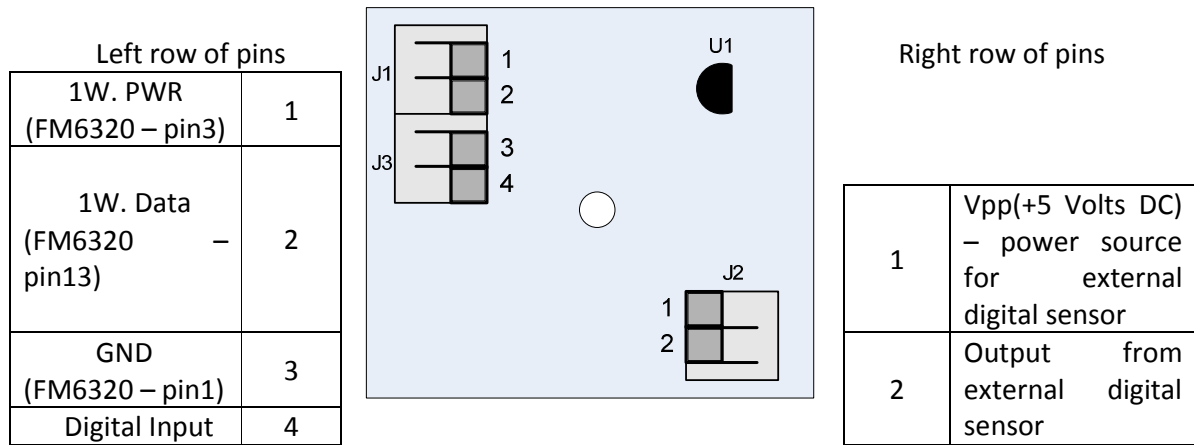

Figure 8 Digital thermometer DS1820 and TTI 100 connection scheme

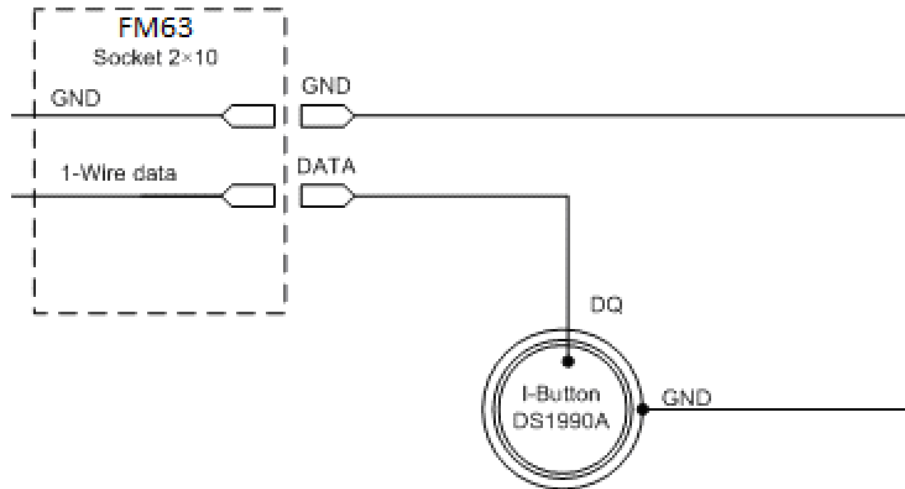

Figure 9 Digital key "I-Button" DS1990A connection scheme

Fuel tank sensors

A fuel tank level sensor exists in most of the cars, which shows the approximate fuel level in the driver's indicator panel. It is possible to connect FM6320 Analog input (if sensor returns analogue signal proportional to fuel level). Figure 10 describes the connection scheme to the FM6320 and fuel tank sensor. After the connection to the tank fuel level sensor, calibration is needed. Calibrations needed due of the fact that most fuel tank sensors are not linear. Calibration is being performing by measuring voltage dependence on volume of fuel in tank.

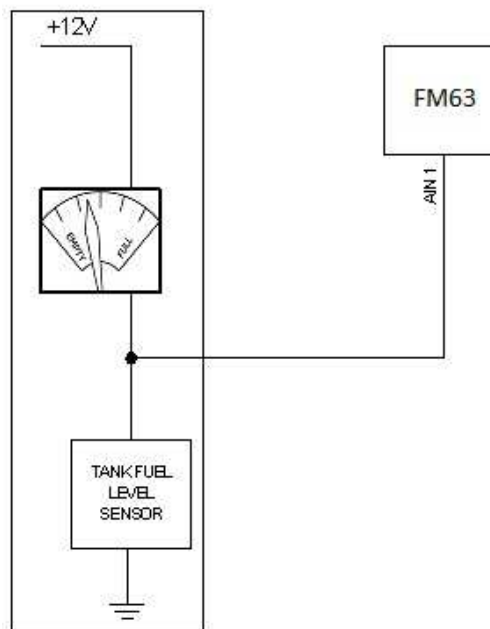

Figure 10 Fuel tank sensor

Impulse counters

Figure 11 describes the connection scheme to the FM6320. Here two pulse meters are used, where one is mounted on the direct flow valve and the other on the return flow valve. Data from both meters is sent to the FM6320. Then FM6320 calculates DIN3-DIN4. Resulting difference equals to fuel consumption. Filter should be used on the direct flow pipe to prevent any damage caused by impurities in the liquid. The filter mounted in the meter inlet is only a safety filter and it is too small to act as a strainer.

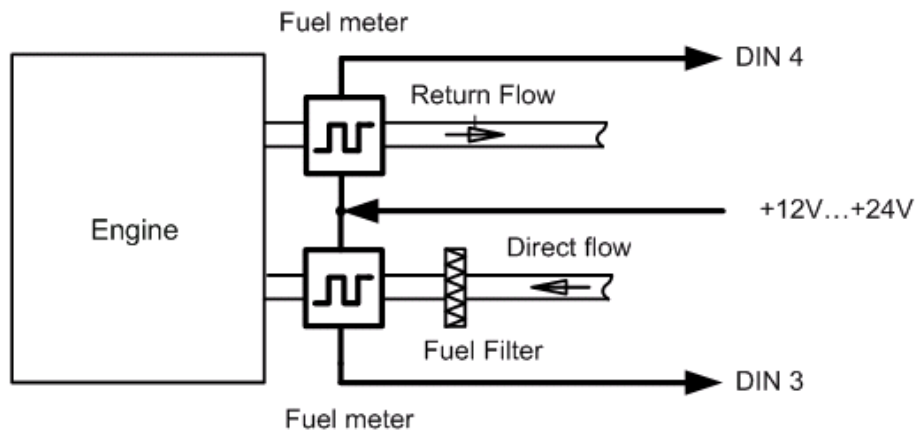

Figure 11 Pulse fuel meters connection scheme

Alarm buttons, door sensors, etc

Alarm buttons, door sensors, ignition, etc return two states: high or low voltage. Digital inputs should be used to read this information. Figure 12 below shows how to connect alarm button, door sensor, etc.

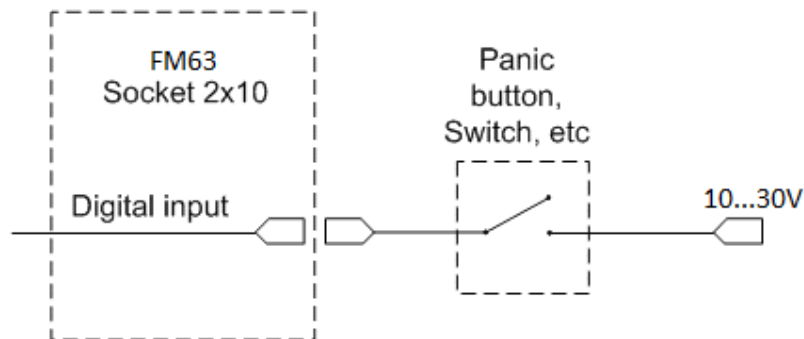

Figure 12 Panic button connection

In cases when sensor output signal is negative an additional relay has to be installed to convert negative signal to positive.

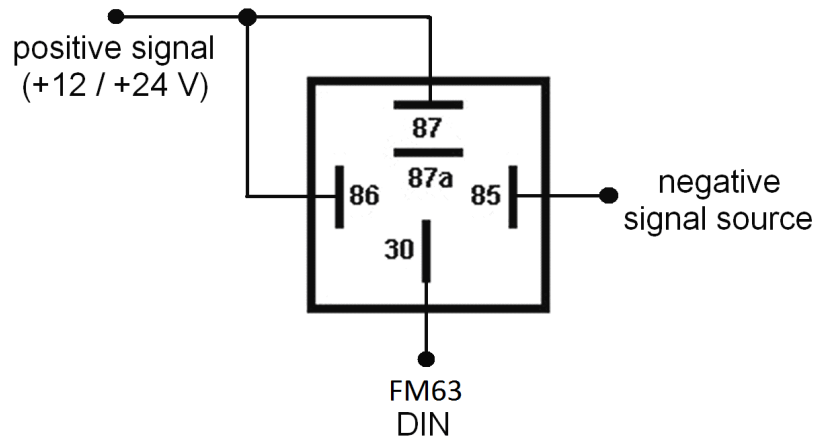

Figure 13 Inverting relay connection

Immobilizer relay

When connected as shown below, FM6320 disables engine starter when output is ON. More details about relays can be found below.

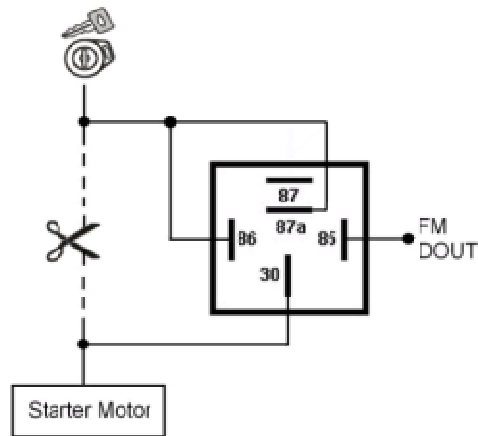

Figure 14 Immobilizer relay connection

Relays

A simple automotive relay is used to invert input signal or to immobilize engine starter. Note, that they are available as 12 or 24 Volt.

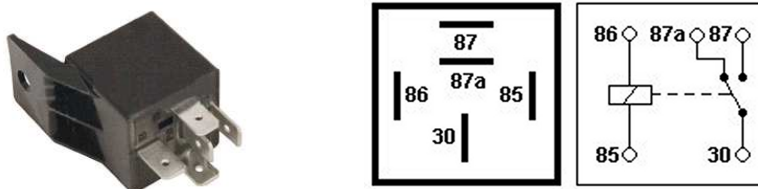

Figure 15 Relay pinout

LV-CAN200

Light vehicle CAN adapter, which allows to read CAN data from light vehicles. LV-CAN200 supports more than 1200 models of vehicles.

Readable data:

- Vehicle Driven Distance
- Total fuel consumption
- Fuel level (Dashboard)
- Engine speed (RPM)
- Vehicle speed (wheel)
- Acceleration position



Figure 16 LV-CAN200 adapter

Technical details:

- Power supply (+9... +50)V DC
- Power supply current:
 - Active mode max 50mA
 - Standby mode max 2mA
- Working temperature -40..85 °C
- Max working humidity 85 % (non condensate)



Information about LV-CAN200 installation schemes will be provided individually by sales representative.

ALL-CAN300

ALL-CAN300 is designed to acquire CAN data from any kind of transport (light vehicles, trucks, buses, agriculture transport, special transport). ALL-CAN300 supports more than 1800 models of vehicles.



Figure 17 ALL-CAN300 adapter

Supported OnBoard computer data:

- Ignition indication
- Vehicle mileage
- Vehicle speed
- Total fuel consumption
- Fuel level (Dashboard)
- Acceleration position
- Engine temperature
- Engine working
- Engine lifetime
- Alarm
- Driver's seat belt
- Passenger's seat belt

Technical data:

- Power supply (+9... +50)V DC
- Power supply current:
 - Active mode max 50mA
 - Standby mode max 2mA
- Working temperature -40..85 °C
- Max working humidity 85 % (non condensate)

4 FIRMWARE

4.1 Updating firmware using USB cable

FM6320 functionality is always improving, new firmware versions are developed. Current module firmware version can be retrieved from configurator. See configuration description for details. Contact sales manager to get the latest firmware.

Connect FM6320 to PC with the USB cable. Launch “Firmware Updater”, select COM port to which device is connected, click connect, and when IMEI and Firmware version fields are filled, start the update. Device needs some time to send IMEI and Firmware version, so do not be afraid if IMEI will not show up immediately, disconnect and after 1-2 minutes try to connect again. When starting update device will open link with updater. With link open device downloads firmware and starts installing. Wait until updater becomes green and it gives message that firmware is done. Update process may take up to several minutes.

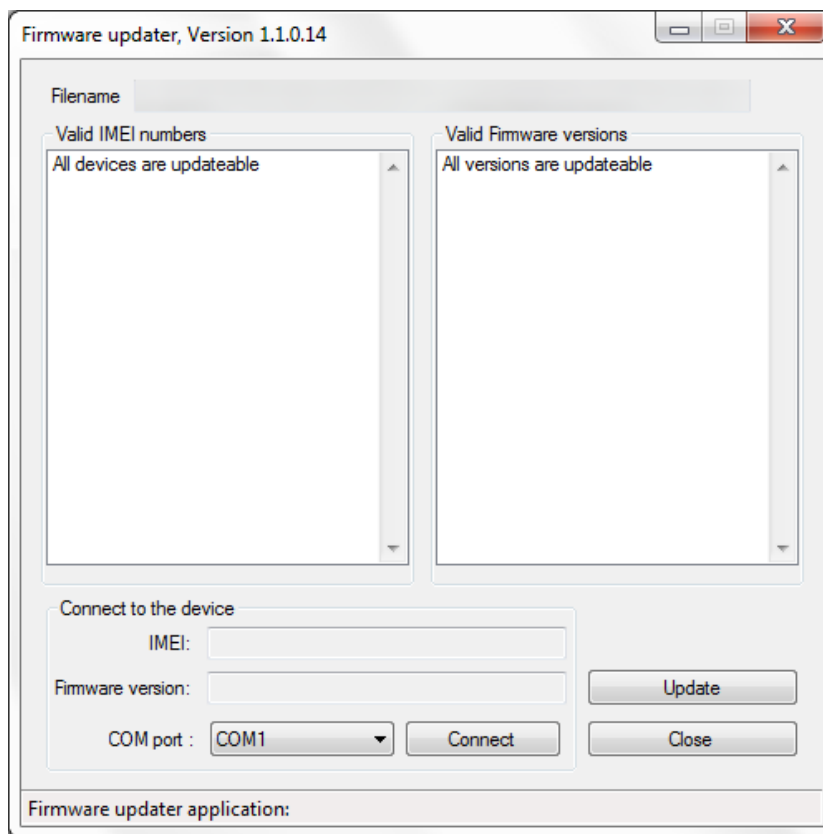

Figure 18 FM updater screen

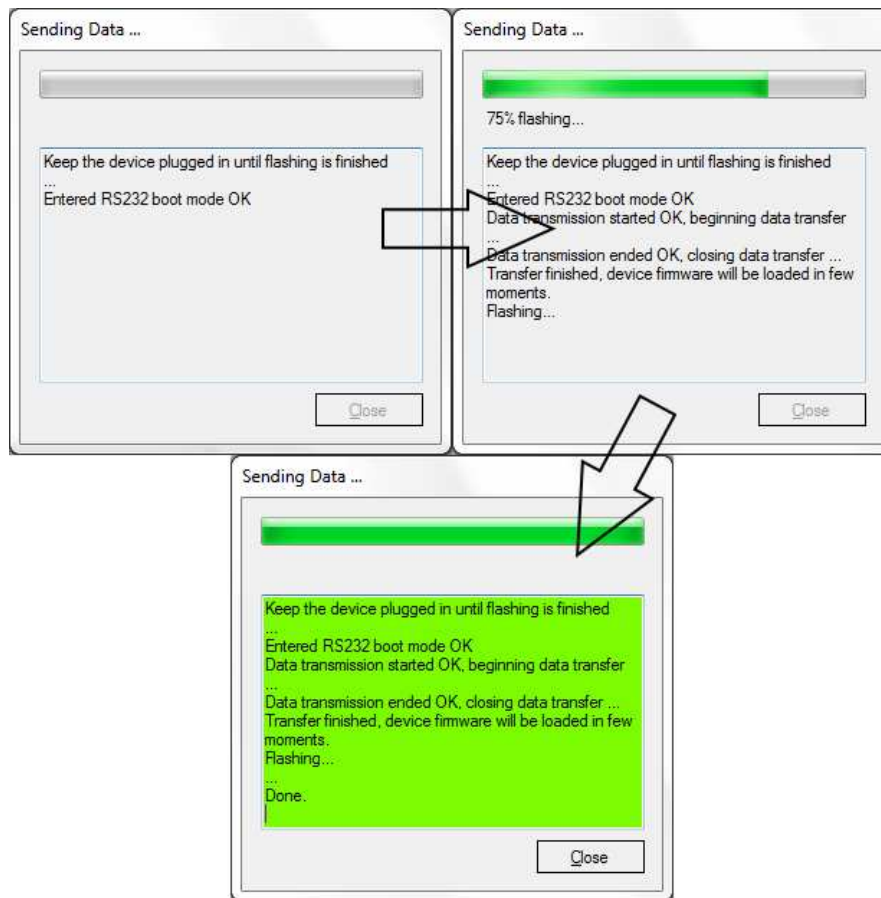

Figure 19 FM firmware updating finished

You may now close the update window and start using your FM6320 device.

5 OPERATIONAL BASICS

5.1 Operational principles

FM6320 module is designed to acquire records and send them to server. Records contain GPS and I/O information. Module uses GPS receiver to acquire GPS data and is powered with 3 data acquire methods: time-based, distance-based and angle-based. Method's details are described in Data Acquisition chapter 9. All data is stored in flash memory and later can be sent via GPRS/3G or SMS channels. GPRS/3G mode is the most preferred data sending mode. SMS mode is mostly used in areas without GPRS/3G coverage or when GPRS usage is too expensive.

GPRS/3G and SMS settings are described in chapters 6.3.5.1 and 6.3.5.3. FM6320 communicates with server using special data protocol. Data protocol is described in device protocols documentation. Please contact Teltonika sale manager to find out more about protocols documentation purchase.

FM6320 can be managed by SMS commands (SMS Command list is described in SMS Command List section) and GPRS commands (GPRS Command list is described in GPRS Command List section). Module configuration can be performed over TCP or via SMS. Configuration parameters and modes are described in device protocols documentation.

5.2 Operational Modes

FM6320 is designed to operate in two different modes: Normal Mode and Deep Sleep Mode (Standby mode). Normal Mode means that FM6320 is fully functional and performs all the functionality mentioned above in Operational principals section.

Deep Sleep Mode is designed to dramatically reduce power consumption. It is a separate mode and certain conditions must be fulfilled to switch from Normal operation and enter this mode. Detailed information about how FM6320 enters/exits Deep Sleep Mode and what functions does FM6320 perform while in this mode can be found in chapter 11.

5.3 Accelerometer

FM6320 has a built in 3 axis accelerometer which allows the device to indicate if vehicle is moving or not, as well as measure acceleration. Accelerometer sensitivity can be configured – it has 2 configurable global parameters: start and stop timeouts that define time intervals in seconds. To indicate that a vehicle is moving, FM6320 constantly (in frequency of 50 Hz) checks for g force change on X, Y and Z axes. If measured g force keeps exceeding the set limit (it is not configurable) for defined time interval in “Movement Filter Start” field (Figure 20), then the vehicle is considered as moving. Same settings for idle indication apply – if g force change is less than the set limit for time interval defined in “Movement Filter Stop” field then the vehicle is considered as idle (not moving).

Example for default parameters: Movement Filter Start = 1 and Movement Filter Stop = 30 means that movement will be detected after 1 second and stop will be detected after 30 seconds of inactivity.

The image shows a dialog box titled "Accelerometer Settings". It contains two input fields, each with a spin button and a unit indicator "s.". The first field is labeled "Movement Filter Start" and has the value "1". The second field is labeled "Movement Filter Stop" and has the value "200".

Figure 20 Accelerometer settings

5.4 Total Odometer

Total odometer is used to calculate travelled distance in FM6320 as a separate I/O element. When FM6320 detects movement, it starts counting distance using GPS signal or reading from selected source. If GPS is selected: every second it checks current location and calculates distance between current and previous point. It keeps adding these intervals until it is time to make a record, then FM6320 records its location and adds odometer value, which is equal to the sum of all distances, measured every second. When record is made, it continues to add distance till next record. If one of other sources is selected FM6320 reads value from that source instead of counting it by GPS.

Total odometer current value can be set to change calculation start point for Total Odometer if GPS source is selected

5.5 Profiles

FM6320 has 4 profiles saved in Flash memory of the module. Every profile has a list of parameters, which enables FM6320 to operate in different modes while using different profiles. The easiest way to understand what is a profile is to compare it to a list of instructions that are written for different cases. You are allowed to setup up to 4 different module behaviours. Global

parameters contain settings that are common for all 4 profiles. This means that if FM6320 is set to call to predefined number, you will be able to call it while using any profile.

Profile 3 is default profile for FM6320. It is always loaded on the very first start-up and further profile switching is proceeded after operator scan or I/O element changes.

Switching between profiles (changing behaviour) can be performed by GSM Operator (mostly used for roaming applications), or by Profile switching depending on I/O Event (on I/O value changing). More information about Profile switching functionalities can be found in chapters 7.1 (Switching by GSM Operator) and 7.2 (Switching by I/O Element).

5.6 Features

Using available features can greatly increase FM6320 usability options.

5.6.1 Scenarios

Six scenarios are available on FM6320 device:

- Any Digital Output can be used by scenarios: Authorized Driving/Immobilizer, iButton notification, ECO driving/Green driving, Overspeeding and Jamming detection.
- Excessive idling functionality does not use Digital Output

5.6.1.1 ECO driving/Green driving Scenario.

Gives the ability to periodically monitor driving characteristics and warn the driver against over accelerating, braking or cornering. More about ECO driving/Green driving read in chapter 12.1

5.6.1.2 Over Speeding Scenario.

Helps to prevent from exceeding fixed speed and inspects driver if needed. Any DOUT (which is configured) is controlled by scenario for user needs, to manage buzzer, LED etc.

5.6.1.3 Authorized Driving and Immobilizer Scenario.

Gives ability to use vehicle for 500 specific iButton owners (specified in iButton list). Any DOUT (which is configured) is controlled by scenario for user needs, to manage immobilizer, buzzer, LED etc.

Vehicle can be used only if iButton is connected. In this scenario iButton list is not used - connect any iButton to pass Immobilizer security. Any DOUT (which is configured) is controlled by scenario for user needs. DOUTX is continuously OFF. DOUTX turns ON if Ignition turns ON (Din1=1). After iButton ID is read (any iButton is attached), DOUTX turns OFF. After iButton identification DIN1 (ignition) can be turned OFF (Din1=0) for configured Ignition timeout (by default 30 seconds), otherwise immobilizer must be repeated.

5.6.1.4 iButton notification.

Scenario used to inform user that I button was read succesfully. When scenario is enabled, and iButton tag is detected, configured DOUT goes ON for configurable duration (min: 0.1 s; max: 10.00 s; default: 0.2 s). If Immobilizer scenario is enabled and iButton's indication scenario is enabled and the same DOUT controls are chosen then in case iButton is attached DOUT is not affected.

iButton's event generation works as a standard IO event generation

5.6.1.5 Excessive idling.

If ignition (DIN1 or Power Voltage) is on and vehicle is not moving, FM6320 after configured time period generate event. When vehicle starts moving FM6320 after configured time period generate event that vehicle idle time ends.

5.6.1.6 Jamming detection.

Radio jamming is the (usually deliberate) transmission of radio signals that disrupt communications by decreasing the signal to noise ratio. When jamming detection is enabled, FM6320 informs (with buzzer or LED, connected to any DOUT) driver about jamming event.

5.6.1.7 Crash detection.

If Crash detection is enabled, it monitors acceleration on each axis, if acceleration exceeds configured value; event with value "1" is generated.

* Crash detection scenario available from firmware Ver.00.02.34



Note: Authorized Driving and Immobilizer Scenarios are combined into a single scenario.



Note: All scenarios can be activated at the same time and one DOUT can control all scenarios.

5.6.2 Trip

Trip customizable feature enables user extended monitoring of performed trips (from engine start at present location to engine stop at arrived location), log their start and stop points, view driven total distance. Event will be **generated (included into send records) only** when trip starts and finishes.

5.6.3 Geofencing

Geofencing is another feature which is highly customizable and can detect wherever a car enters or leaves customized areas. More about Geofencing can be read in chapter 6.3.6.4.

5.6.4 Auto Geofencing

Auto Geofencing feature, if enabled, is activated automatically by turning off car ignition. Next time before driving user has to disable Auto Geofencing with iButton or by turning on car ignition. In case of theft, the car leaves Auto Geofencing zone without authorization and FM6320 device automatically sends high priority record to AVL application.

5.6.5 iButton list

iButton list is used to enter authorized iButton ID codes, which are used to authenticate driver in Authorized driving and Auto Geofencing options.

6 CONFIGURATOR

6.1 STARTUP

FM6320 configuration is performed via FM6320 Configurator program. FM6320 Configurator can be downloaded from [FM6320 Downloads](#). Contact sales manager to get the latest FM6320 Configurator version. FM6320 configurator operates on Microsoft Windows OS and uses MS .Net Framework 3.5 or higher. Please ensure that MS .Net Framework 3.5 or later is installed on your PC before starting configurator. Latest MS .Net Framework version can be downloaded from official Microsoft web page.

Module configuration is performed over USB cable or COM connection. Configuration process starts from starting FM6320 Configurator program and then connecting to FM6320 device via “Connect” button located on the top left corner of configurator. If one of the communication sources (USB cable or COM2) is connected to the device, the configurator will detect it automatically and if connected successfully IMEI, version fields, which were empty, now are filled with certain numbers depending on Modem IMEI and firmware version of your device (Figure 21).

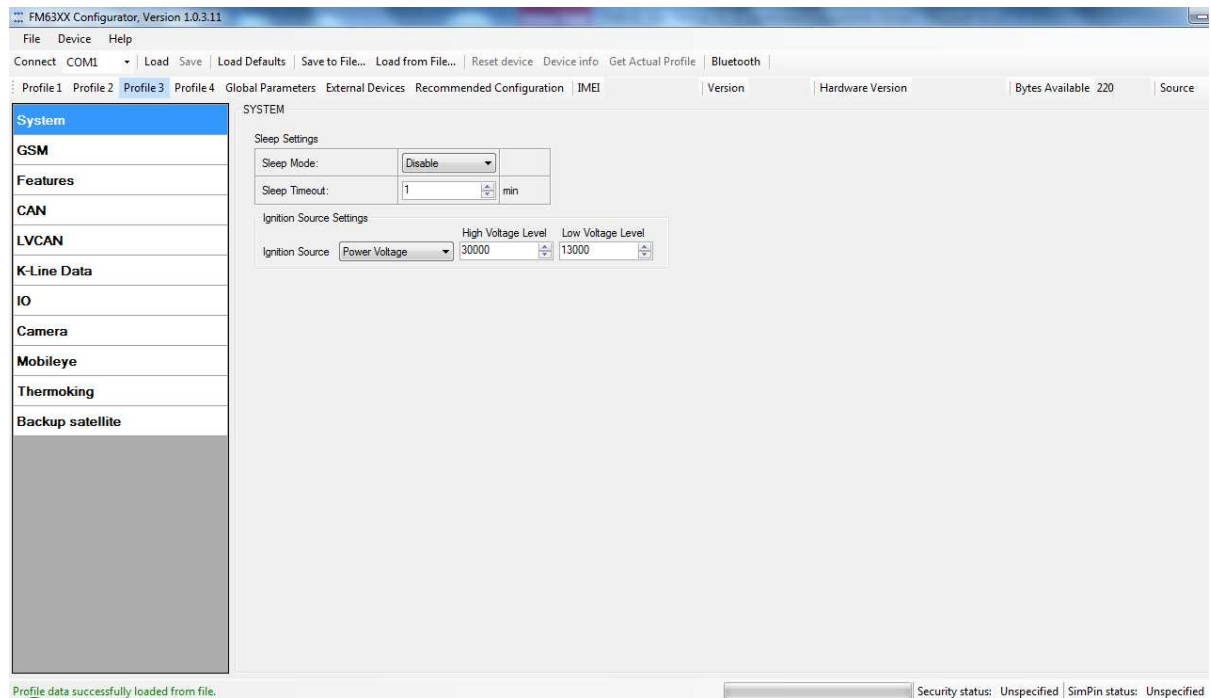

Figure 21 FM6320 Configurator window

6.2 Configurator structure

FM6320 has four user editable profiles, which can be both loaded and saved to the device. User can also revert to default settings, by pressing Load Defaults button. Any modification of configuration settings has to be saved to FM6320 device, otherwise it will not be written to device flash memory.

FM6320 Configurator is divided into 5 main areas (Figure 22):

1. Buttons area;
2. Information area;
3. Profiles or global parameters selection area;

4. Settings menu;
5. Configurable parameters and values menu.

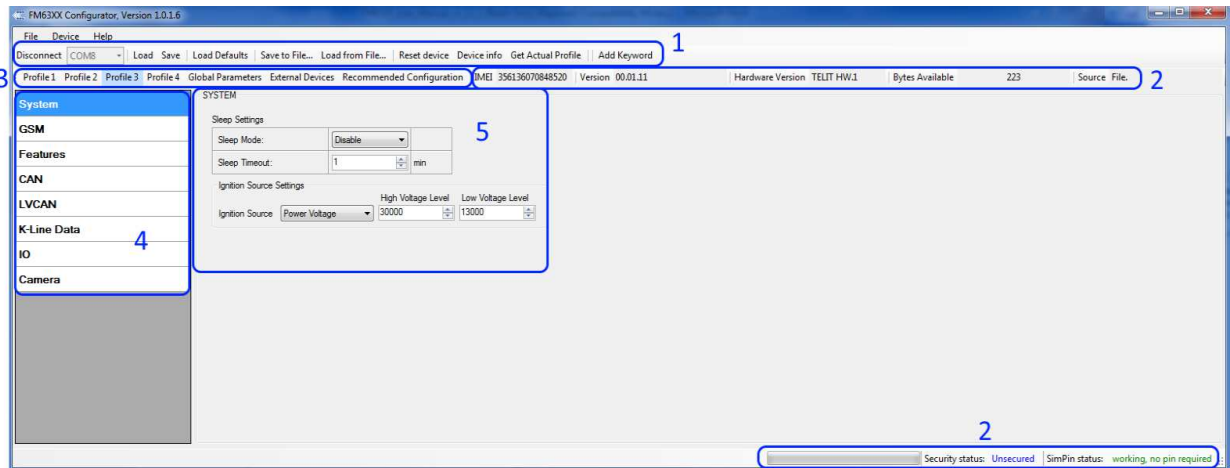

Figure 22 FM6320 Configurator window structure

6.2.1 Buttons area

Table 8 Configurator buttons area description

Main Buttons	
Button	Description
<i>Connect</i>	connects the device
<i>Load</i>	reads configuration parameters from FM6320 Flash memory
<i>Save</i>	saves configuration parameters to FM6320 Flash memory
<i>Load Defaults</i>	loads default FM6320 settings that later can be modified
<i>Save to File...</i>	allows user to save currently entered settings to .XML or .Bin file for later usage or update over FOTA.
<i>Load from File...</i>	allows user to load configuration saved in .XML or .Bin extension file
<i>Reset device</i>	reboots FM6320 and displays processor firmware version
<i>Info device</i>	allows user to see actual device I/O's information
<i>Get Actual Profile</i>	Informs user about active profile
Additional Buttons	
Button	Description
<i>SIM PIN</i>	allows to enter PIN code if inserted SIM card has activated PIN code security
<i>Add Keyword⁴ / Change Keyword / Switch Security Off</i>	buttons are used to protect configurator from unauthorized access to configuration

6.2.2 Information area

FM6320 information area is divided into 2 parts located on the top right and bottom of the configurator. When configurator is connected to the device via USB or COM2 port all necessary information about the device is shown here:

⁴ Keyword is of 4 - 10 symbol length (Latin text and/or numbers). If a keyword is set, every time user reconnects FM6320 to USB or COM ports he will be asked to enter a valid keyword when connecting FM6320 to configurator. User is given 5 attempts to enter a valid keyword before blocking the configurator.

- IMEI – unique number for every FM6320 and usually servers recognize different devices by this number;
- Version – firmware version of the device;
- Hardware version – hardware version of the device;
- Bytes available – shows how much bytes remains in configuration.
- SOURCE – configuration source (device or file);
- STATUS – status bar;
- SECURITY STATUS – status of the configurator security;
- SIM PIN STATUS – status of SIM card in the device;

6.2.3 Profiles/global parameters selection area

FM6320 has 4 user editable profiles stored in Flash no. 1-4 memories and one extra profile stored in Flash no. 0 which cannot be edited by user. Profile from Flash no. 0 is used by system and cannot be selected as active, while profiles from Flash no. 1-4 are fully editable and can be selected as active.

Reading profiles, Global parameters and External Devices from Flash memory is a very simple procedure. By pressing “Load” button all 4 profiles, Global parameters and External Devices are loaded to the configurator (Figure 23). To configure 3rd profile choose the TAB named “Profile 3” and all configurable parameters of this profile will be available to change.

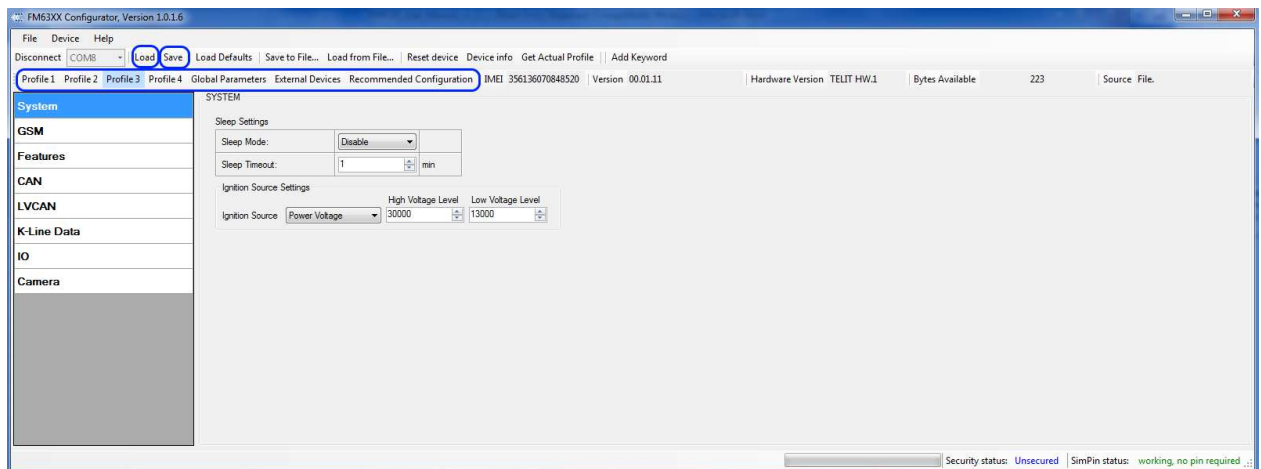

Figure 23 FM6320 Configurator profiles loading window

After changing profile, Global parameters and External Devices, changes can be saved to FM6320 Flash. By pressing “Save” button all 4 profiles, Global parameters and External Devices are saved to the Flash (Figure 24).

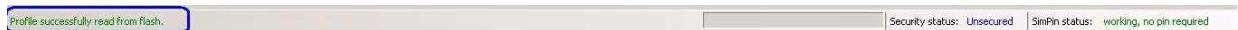

Figure 24 FM6320 Configurator profiles saving information

6.3 Parameters Configuration

6.3.1 Global parameters Settings

Global parameters do not depend on selected profile; they are common for all profiles. To configure these parameters choose the TAB named “Global Parameters” and make all necessary changes (Figure 25)

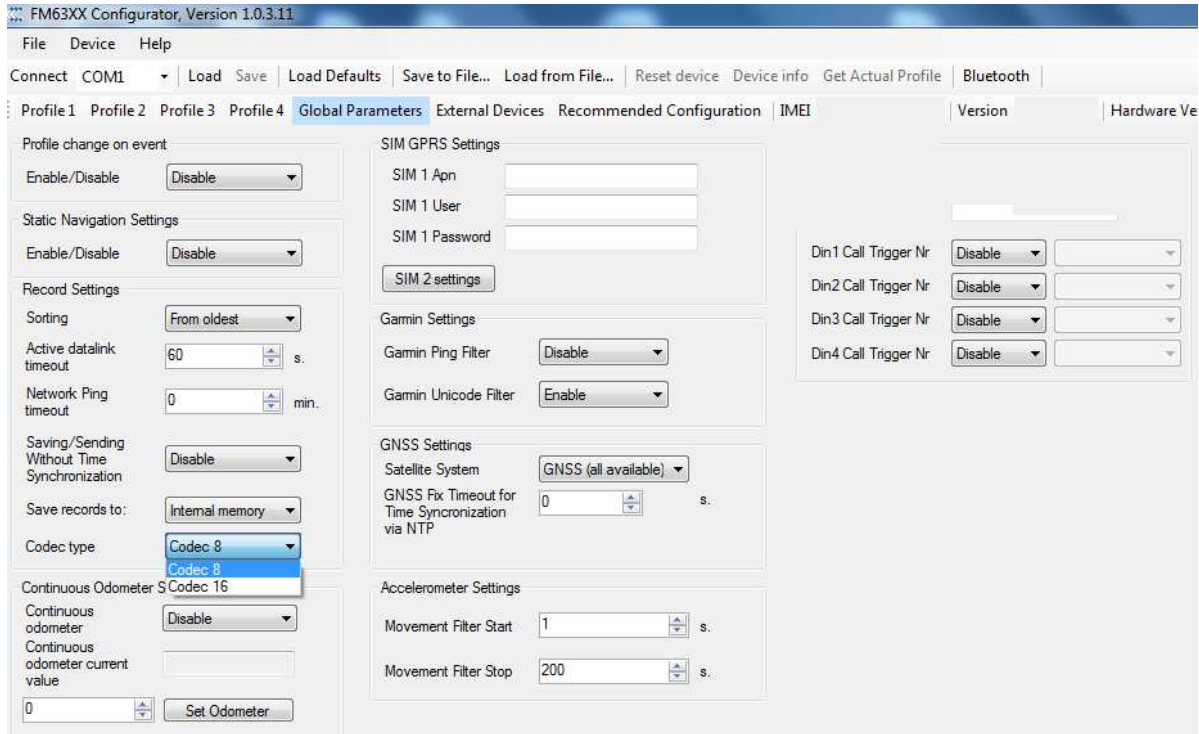

Figure 25 FM6320 Global parameters

Table 9 Global parameters description

Parameter Name	Parameter description
Profile change on event	Allows selecting profile switching method. When ‘Profile change on event’ is disabled – FM6320 switches profiles depending on GSM operator code method. Otherwise it switches profiles depending on I/O events.
Record Settings	Are used to switch between two data sending modes: starting from newest records or starting from oldest record. Active data link timeout defines how many seconds should FM6320 keep connection to the server before disconnecting after successful data transfer. Note that even if it disconnects from server, it always keep active GPRS session.
Accelerometer settings	Defines accelerometer how many seconds should movement be detected by accelerometer in order to set movement for FM6320 application and how many seconds after movement is not detected by accelerometer FM6320 application should treat like movement is still there.
Static Navigation settings	Functionlity filters GNSS data and filters GNSS jums till movement or ignition detected. Parameter can be enabled or disabled.
GNSS Settings	Allows choosing satellite systems – GNSS(all available), GPS, GLONASS, GNSS+SBAS, GPS+SBAS
Total Odometer settings	Allows chosing source for Total Odometer functionality and start value. Value is saved as Total Odometer I/O must be enabled .

Parameter Name	Parameter description
Garmin settings	Allows enabling or disabling functionality and Unicode.
DualSim GPRS Settings	Allows to enter Sim Apn, user name and password.
Tachograph settings	Allows to choose ignition source for tachograph.
Codec Type	Allow to choose codec 8 or codec 16 protocol of device

6.3.2 External Devices Settings

External Devices do not depend on selected profile; they are common for all profiles. To configure these parameters choose the TAB named “External Devices” and make all necessary changes (Figure 26)

Figure 26 FM6320 External Devices

Table 10 Global parameters description

Parameter Name	Parameter description
FMS/Tachograph Settings	Are used to configure CAN line and Tachograph setting such as Enable/Disable, baudrate, operation mode, tachograph ignition source, tachograph type.
Web DDD	User can enable Web DDD synchronization functionality, enter WebDDD server domain and port.
Analog Input Settings	User can change the range of analog inputs. There are two possible changes: 10 V (0-10 V) and 30 V (0-30 V).
COM1 and COM2 Settings	Configures COM1 and COM2 ports. User can configure baudrate, working mode, enable/disable timestamp and change CMD ID(used to identify from which COM port data came).
RS485 Settings(COM1)	Configures RS485 settings such as activation of RS485 protocol, baudrate and working mode.
LLS Sensor Settings	Allows user to set LLS sensors addresses in preferred order
Network Time	GNSS Settings, where you Enables/Disables time synchronization from

Parameter Name	Parameter description
Protocol	NTP server when there is no valid GPS signal from satellites

6.3.3 Settings and configurable parameters menu

Every FM6320 profile has seven main groups of parameters:

1. System – main parameters for all device;
2. GSM has 7 subgroups:
 - a. GPRS
 - b. GPRS Limits
 - c. SMS Security
 - d. SMS Data
 - e. SMS Events Numbers
 - f. SMS Events
 - g. Operator list
3. Features has 6 subgroups:
 - a. sMode
 - b. Scenarios
 - c. Trip
 - d. Geofencing
 - e. Auto Geofencing
 - f. IButton List
4. CAN
5. LVCAN
6. I/O
7. Camera

6.3.4 System Settings

System settings have 2 configurable parameters (Figure 27):

- Sleep settings, where user can disable sleep, turn on or deep sleep.
- Ignition source settings, for choosing which ignition source prefer to use DIN1, DIN2, DIN3, DIN4, Movement or External Voltage. While using External Voltage levels must be set.

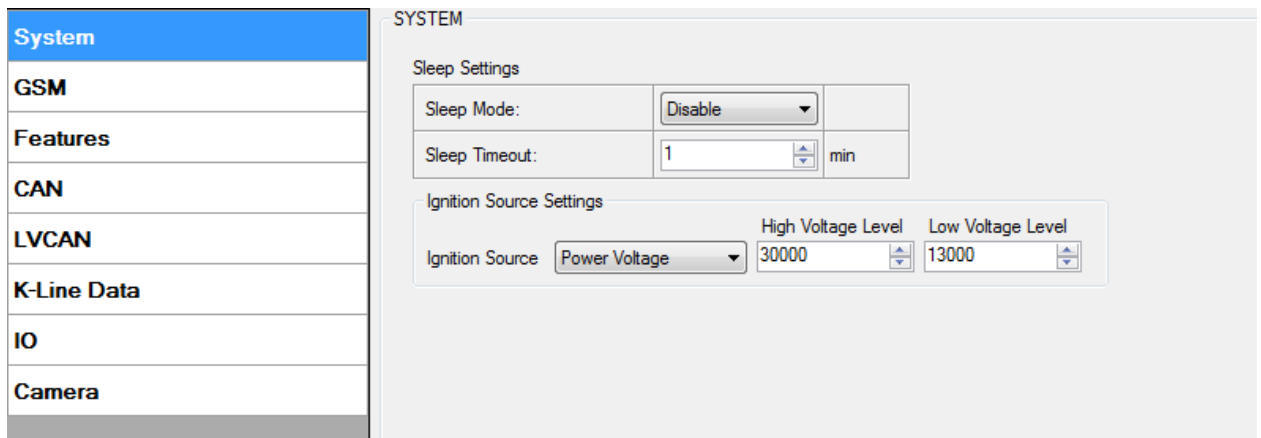

Figure 27 System Settings Configuration

When Vehicle Alternator is working supply voltage is usually 2-4 Volts higher than nominal battery voltage. By such difference FM6320 can identify when engine is on.

Example:

High Level: 15000
 Low Level: 13000

If External Voltage 14V, then ignition is ON.
 If External Voltage 12V, then ignition is OFF.
 If External Voltage 16V, then ignition is OFF.

6.3.5 GSM Settings

6.3.5.1 GPRS

'GPRS' defines main parameters for FM6320: destination server Domain (can be entered either IP or domain name) and port. Also both TCP and UDP protocols are supported. Server Response Time defines the time how long device will wait for response from server before device denies the connection between FM6320 and server.

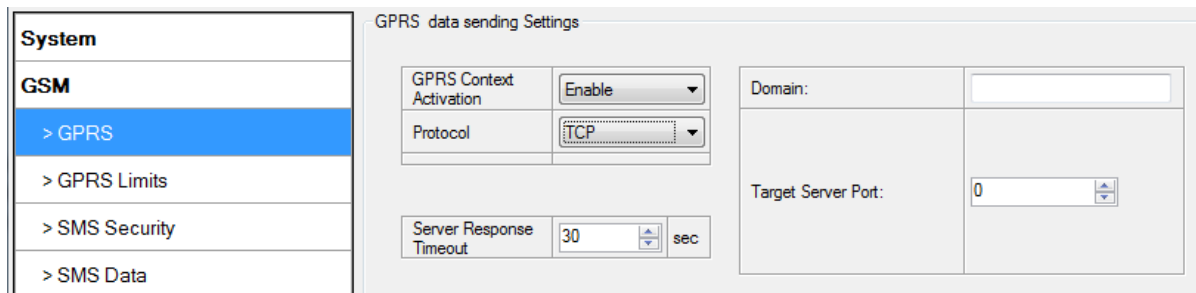

Figure 28 GSM->GPRS Settings Configuration

6.3.5.2 Data limits functionality

Data limit can be configured for Home and Roaming Separately. Currently Min Settings for Home and Roaming are 1MB. User can choose to get SMS notification (in SMS Events section) if Data limit has been reached. SMS is send only one time.

User can get current status of datalimits using SMS: **'getlimits'**.

User can reset data limits using SMS: **'resetlimits'**.

These SMS can be GPRS commands too. When data limit will be hit following scenario will be executed:

In TCP mode:

Open GPRS only if there is high or panic Priority. Send only high or panic priority. Low priority records sending will recover on month 1 day.

In UDP mode:

Open GPRS only if there is high or panic Priority. Send only high or panic priority. Low priority records sending will recover on month 1 day.

6.3.5.3 SMS Security

Essential fields in 'SMS Security' part is 'SMS Login' and 'SMS Password' (Figure 29). This login and password is used with every SMS sent to FM6320. If login and password are not set, every SMS sent to FM6320 device has to include two spaces before command (<space><space><command>).

Command structure: <login><space><password><space><command>.

Examples:

1. SMS login and password are set - "asd 123 getgps"
2. SMS login and password are not set - " getgps"



Phone numbers have to be written in international standard, without using "+" or "00" signs in prefix. **If no numbers are entered in configuration then commands SMS are allowed to be sent from all GSM numbers.**

<p>System</p> <p>GSM</p> <ul style="list-style-type: none"> > GPRS > GPRS Limits <li style="background-color: #0070C0; color: white;">> SMS Security > SMS Data > SMS Events Numbers > SMS Events > Operator list <p>Features</p> <p>CAN</p> <p>LVCAN</p> <p>K-Line Data</p> <p>IO</p>	<p>SMS Security settings</p> <table border="1" style="width: 100%; border-collapse: collapse;"> <tr> <td style="width: 30%;">SMS login:</td> <td style="width: 30%;"><input type="text"/></td> <td style="width: 40%;"></td> </tr> <tr> <td>SMS password:</td> <td><input type="text"/></td> <td></td> </tr> </table> <p>Authorized phone numbers:</p> <table border="1" style="width: 100%; border-collapse: collapse;"> <thead> <tr> <th style="width: 5%;"></th> <th style="width: 95%;">Phone number</th> </tr> </thead> <tbody> <tr><td>▶ 01</td><td style="background-color: #0070C0; color: white;"></td></tr> <tr><td>02</td><td></td></tr> <tr><td>03</td><td></td></tr> <tr><td>04</td><td></td></tr> <tr><td>05</td><td></td></tr> <tr><td>06</td><td></td></tr> <tr><td>07</td><td></td></tr> <tr><td>08</td><td></td></tr> <tr><td>09</td><td></td></tr> <tr><td>10</td><td></td></tr> </tbody> </table> <p style="text-align: right;">(Server Phone Number)</p>	SMS login:	<input type="text"/>		SMS password:	<input type="text"/>			Phone number	▶ 01		02		03		04		05		06		07		08		09		10	
SMS login:	<input type="text"/>																												
SMS password:	<input type="text"/>																												
	Phone number																												
▶ 01																													
02																													
03																													
04																													
05																													
06																													
07																													
08																													
09																													
10																													

Figure 29 GSM->SMS Security Settings

6.3.5.4 SMS Data

SMS data sending Settings enables or disables **periodic** data and event SMS sending to server (Figure 30). Configuration is divided into 4 main parts:

1. SMS data sending settings;
2. SMS Week Time button;

3. Server Phone Number (has to be written in first position of Authorized phone numbers);
4. SMS Events PreDefined Numbers (phone numbers, to which SMS [has to be written in SMS Event Numbers section] events will be sent);

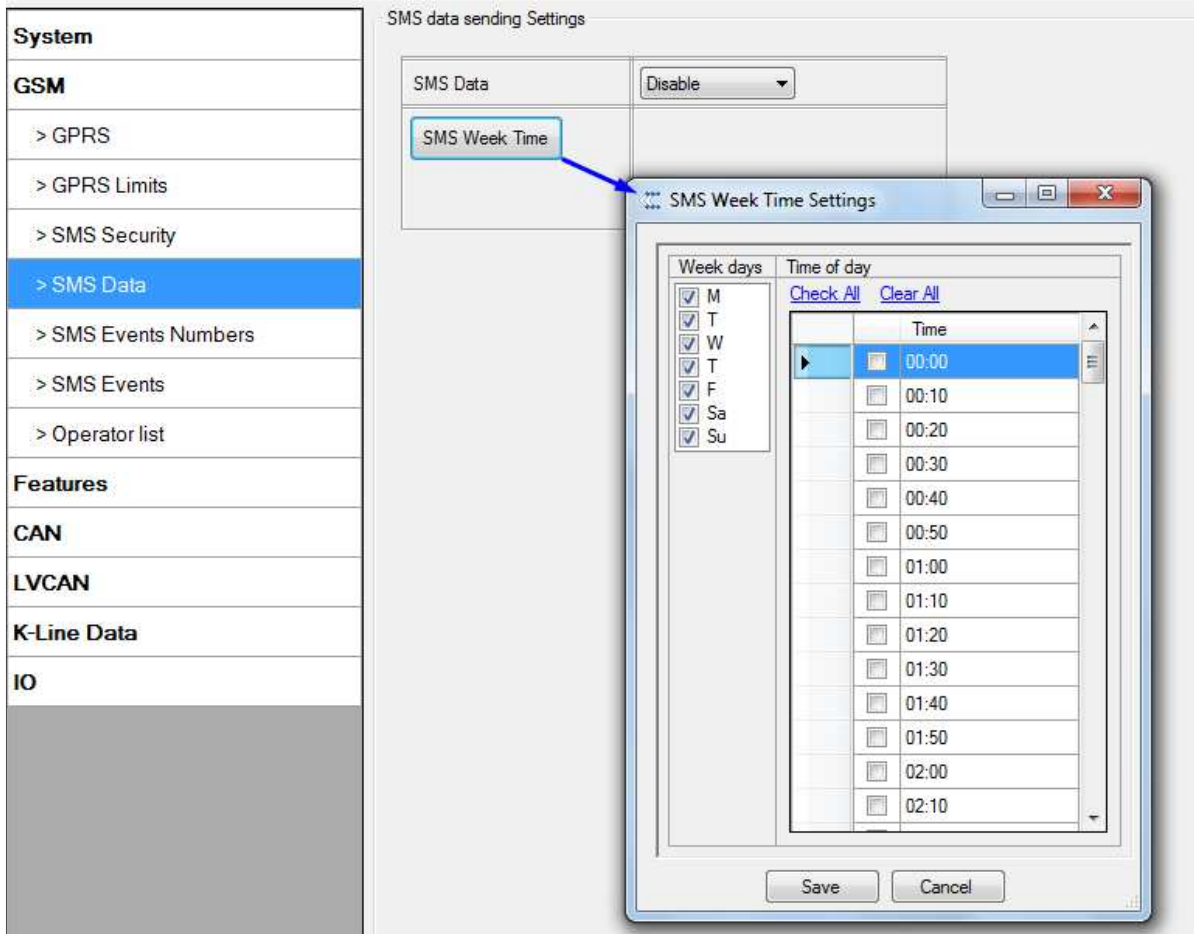

Figure 30 GSM->SMS Settings Configuration (2)

Using these settings FM6320 can send SMS with 24-coordinates in one SMS; it is used in areas where no GPRS coverage is available. Module collects data and sends to server binary SMS containing information about last 24 collected points. SMS sending schedule is set in SMS Week Time tab. 24-Coordinates SMS decoding is described in device documentation document. Please contact Teltonika sale manager to find out more about protocols documentation purchase.

6.3.5.5 SMS Events

FM6320 is able to send SMS messages to PreDefined phone numbers (recipients) if any of selected events are triggered. User can send SMS alert message of selected event to maximum 10 preDefined phone numbers. AVL ID of parameter has to be entered in configuraton to receive its SMS event (Figure 31). PreDfined phone numbers must be entered in SMS Events Numbers list. Maximum 10 recipients are allowed in SMS Events Numbers list (Figure 32).

System		
GSM		
> GPRS		
> GPRS Limits		
> SMS Security		
> SMS Data		
> SMS Events Numbers		
> SMS Events		
> Operator list		
Features		
CAN		

SMS Events			
	AVL ID	Phone number	SMS text
1	1		Event SMS 1
2	1		Event SMS 2
3	66		Event SMS 3
4	0		Event SMS 4
5	0		Event SMS 5
6	0		Event SMS 6
7	0		Event SMS 7
8	0		Event SMS 8
9	0		Event SMS 9
10	0		Event SMS 10

Figure 31 FM3 SMS events List Configuration

System	
GSM	
> GPRS	
> GPRS Limits	
> SMS Security	
> SMS Data	
> SMS Events Numbers	
> SMS Events	
> Operator list	
Features	
CAN	
LVCAN	
K-Line Data	

SMS Events Numbers		Profile Independent
SMS Time Zone:	UTC-00:00	
SMS Events PreDefined Numbers		
	Phone number	
▶ 01		
02		
03		
04		
05		
06		
07		
08		
09		
10		

Figure 32 SMS Events Numbers list

6.3.5.6 Operator List

FM6320 is able to use GPRS with all operators but if any operator is entered in the preferred operator list, FM6320 is allowed to connect to GPRS only when operating in listed operator's network. Also operator list has influence on profile switching (see details in chapter 7.1) if Global parameter "Profile switching on event" is disabled.

FM6320 will not connect to GPRS using network of operator which is listed in black list.

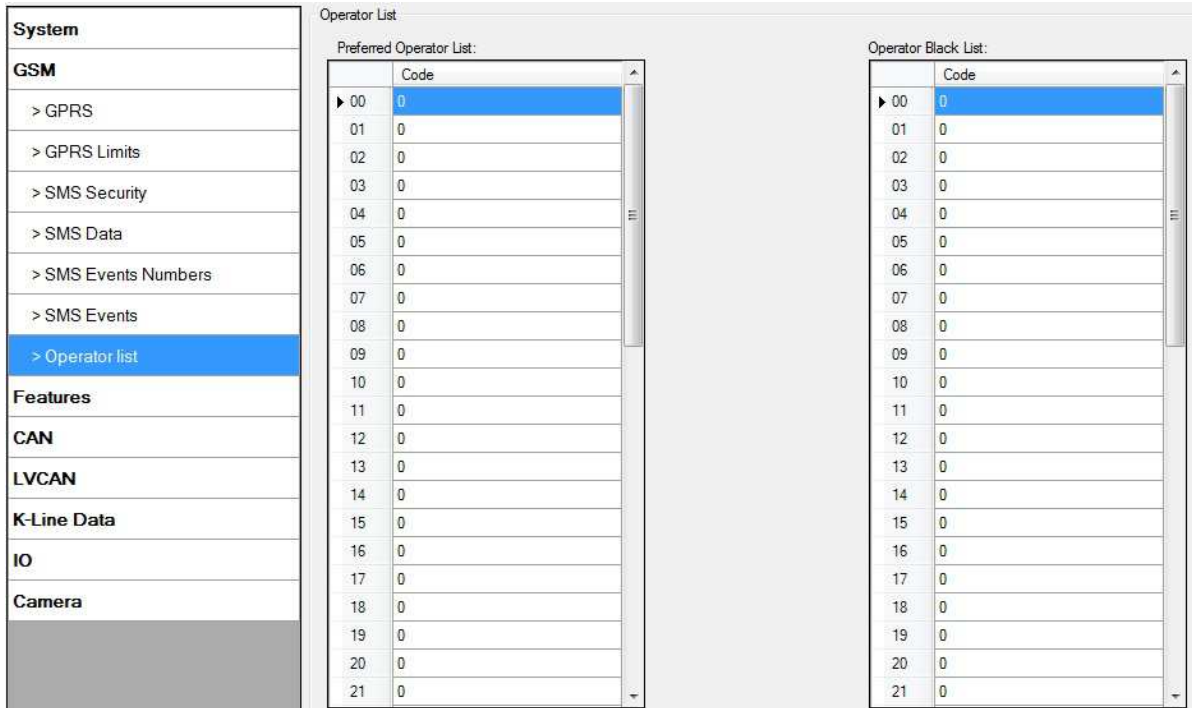

Figure 33 FM6320 Operator List Configuration

6.3.6 Features

6.3.6.1 sMode

FM6320 is able to collect records using four methods at the same time: time, distance, speed and angle based data acquisition (Chapter 9) Send and Save Parameters configuration is available in Features->sMode category (6.3.6.1):

- Min Period – time period change that initializes record save.
- Min Angle – angle change that initializes record save (only if vehicle is moving).
- Min Distance – distance change that initializes record save (only if vehicle is moving).
- Send period – GPRS data sending to server period. Module makes attempts to send collected data to server every defined period. If it does not have enough records (depends on parameter Min. Saved Records described above), it tries again after defined time interval.
- Min speed – minimal speed the vehicle has to move in order to save record (only if neither Min Angle nor Min Distance was triggered).
- GPRS Context Week Time tab – most GSM billing systems charge number of bytes (kilobytes) transmitted per session. During the session FM6320 makes connection and transmits data to a server. FM6320 tries to control the session as much as possible. Session can last hours, days, weeks or session can be closed after every connection in certain GSM networks – this depends on GSM network provider. GPRS Context Week Time defines session re-establishing schedule if session was closed by network. New GPRS context is opened if 10 minutes are left till time checked in table. Therefore if all boxes are checked, FM6320 is able to open new connection anytime. At scheduled time match FM6320 checks for GPRS session activity. If GPRS session is

alive, FM6320 sends data to server according to Send period parameter. If it is not, FM6320 checks if it is able to re-establish the session.

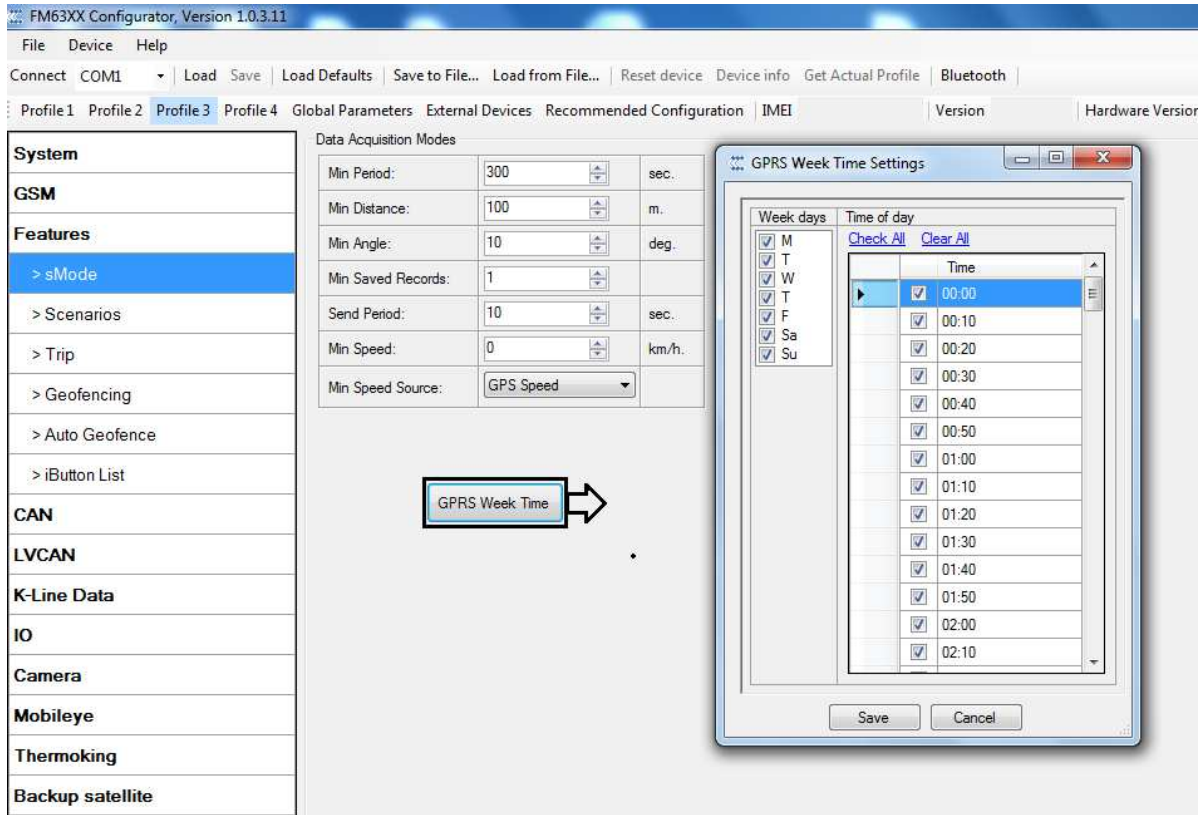

Figure 34 FM6320 sMode>Data Acquisition

6.3.6.2 Scenarios

In scenarios window seven different scenarios are available (Eco/Green Driving, Immobilizer/ Authorizing driving, iButton notification, Excessive Idling, Jamming detection, Over speeding and Crash detection). They have six possible states: disabled, no DOUT control, DOUT1 control, DOUT2 control, DOUT3 control, DOUT4 control (except excessive idling and crash detection). Excessive idling and Crash detection scenario has two states: Disable and Enable. All scenarios can be activated at the same time and all scenarios that use DOUT can control the same DOUT. Scenarios configurable parameters are shown in Figure 35. All values of these parameters are described in Chapter 12.

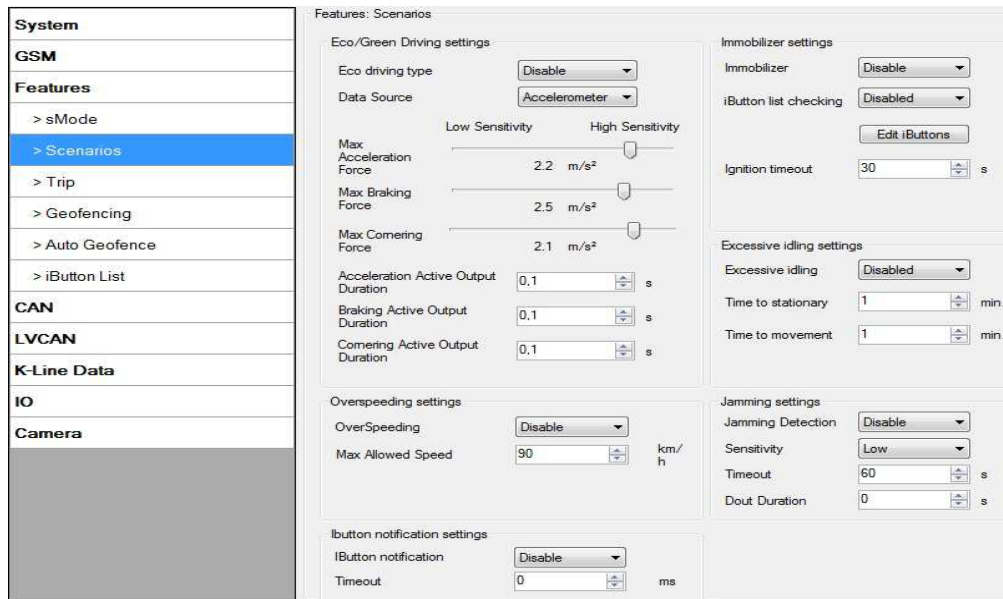

Figure 35 FM6320 Scenarios configuration

6.3.6.3 Trip

Trip window offers user to configure Trip feature. If Trip is enabled configuration of parameters is available:

- Start Speed – speed, which is detected as minimum speed to indicate Trip start.
- Ignition Off Timeout – timeout to wait if ignition was off, to detect Trip stop.
- Odometer Trip Mode – Between records or Continuous can be chosen. For this feature I/O Trip Odometer value feature must be enabled.
- Remember iButton ID – Send ibutton value to server while trip is detected

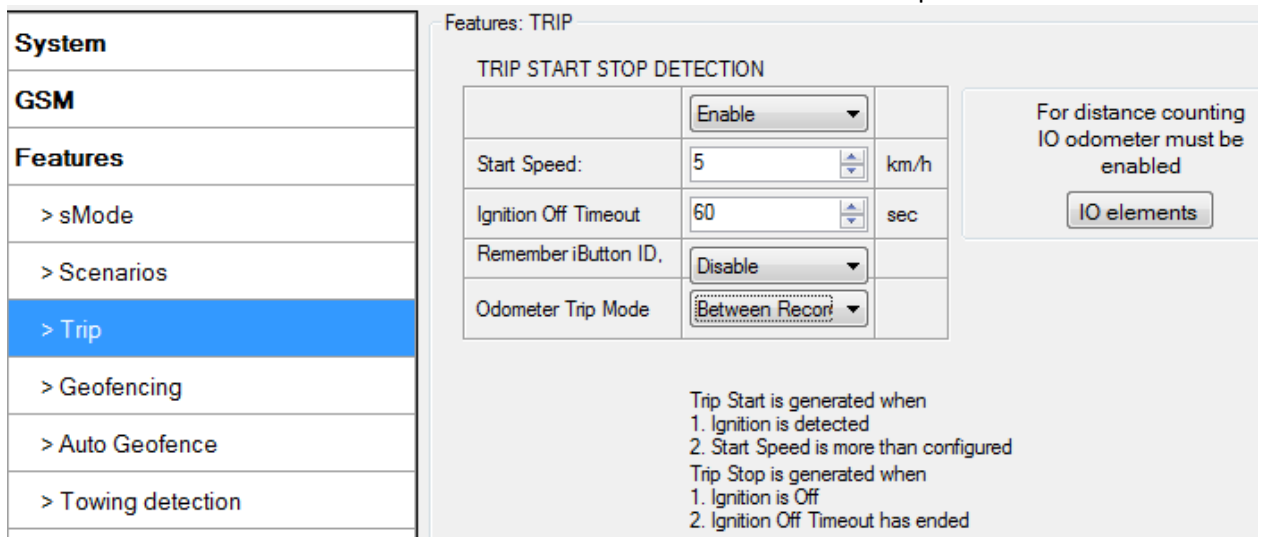

Figure 36 FM6320 Features->Trip Configuration

If I/O Trip Odometer is enabled and Odometer Trip Mode distance counting variable is set to Continuous, Trip distance is going to be counted continuously (from Trip start to Trip stop). This value is written to I/O Odometer value field. When Trip is over and next Trip begins, Odometer Trip value is reset to zero, and it is counted continuously again.

If I/O Trip Odometer is enabled and Continuous Distance Counting variable is set to “Between Records”, then distance is going to be counted only between every record made. This value is written to I/O Trip Odometer value field and reset to zero every new record until Trip stops. If later all Odometer values are summed up manually user gets distance driven over the whole Trip period.

When trip is enabled and Remember iButton ID in trip settings is also enabled, device will remember iButton (during trip) when it is attached. Ibutton value will lose after reset. When iButton value is saved, it will be stored in iButton I/O and will be added with every record. When new iButton is attached, its ID will be added to iButton I/O and old iButton value will be forgotten. When iButton is attached and ignition is not ON, then iButton is saved but value will not be added to I/O. If ignition is not attached in Ignition OFF timeout, then iButton value is removed. It is added only when ignition is set on and trip event occurred. The iButton is removed from iButton IO (set to 0) when trip end event occurs.

6.3.6.4 Geofencing

Geofencing settings:

FM6320 has 50 configurable Geofence zones and it can generate event when defined Geofence zone border has been crossed or overspeeding is occurred in a configured geofence zone.

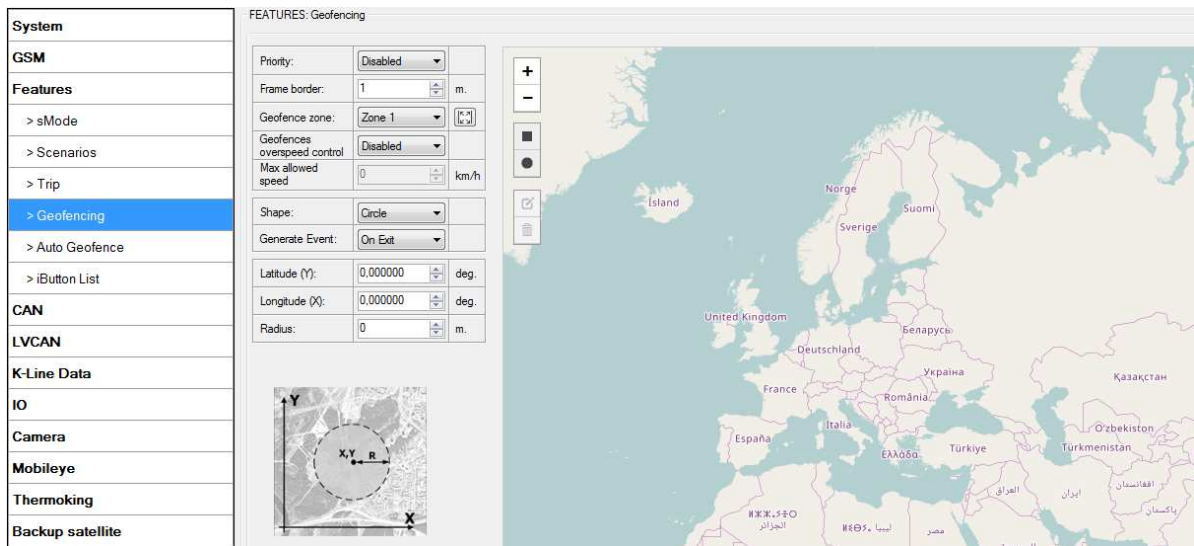

Figure 37 FM6320 Features->Geofencing Configuration (1)

Configuration of the parameters is available in Features->Geofencing (Figure 37)

- Frame border – frame border is an additional border around Geofence zone. It is additional area around defined zone used to prevent false event recording when object stops on the border of the area and because of GPS errors some records are made inside area and some – outside. Event is generated only when both borders are crossed. See Figure 38 for details: track 1 is considered to enter the area while track 2 does not.
- Geofence zone - User can configure upto 50 geofence zones without interfering DOUT control or allowed speed limit of other zones.

- Geofence overspeed control – Option to use any DOUT if overspeed event happens in a configured geozone.
- Max allowed speed – Max allowed speed in a configured geozone

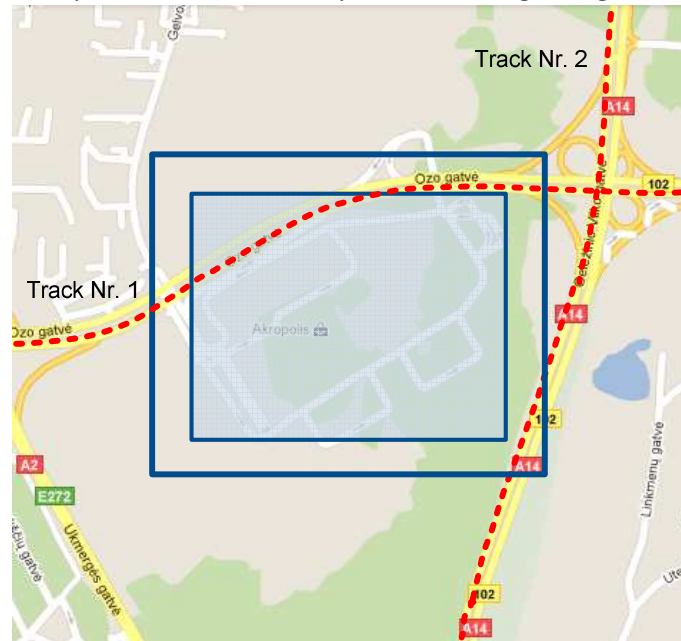

Figure 38 Geofence border

- Shape – can be rectangular or circle
- Priority – priority of Geofence event: low, high or panic, SW21, SW22, SW23, SW24. These levels define priority of event information sending to server. See I/O element description for more details about priorities.
- Generate event (On entrance, On exit, On both) – choose when record will be generated (or no event);
- X1 – geofence zone left bottom corner X coordinate;
- Y1 – geofence zone left bottom corner Y coordinate;
- X2 or R – geofence zone upper right corner X coordinate (radius of circle when Circular zone used);
- Y2 – geofence zone upper right corner Y coordinate;

6.3.6.5 AutoGeofencing

AutoGeofence – the last known position after movement = off. If your car is being taken away – you can be notified. The shape and size of the geofence zones are configurable. There is a possibility to state whether entering in or out of the geofence triggers an asynchronous message.

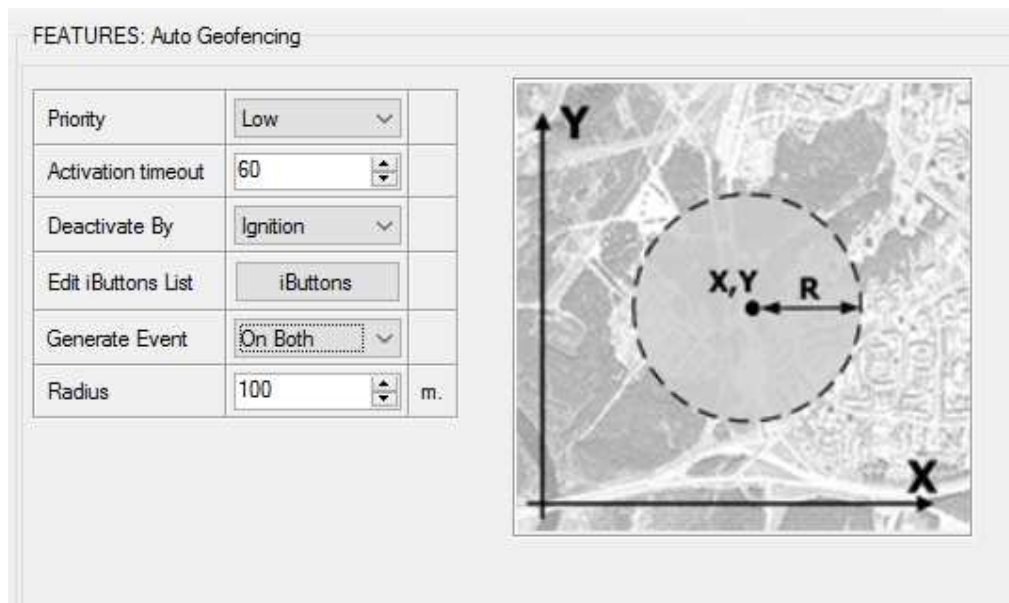

Figure 39 FM6320 Features->Geofencing Configuration (2)

Auto Geofencing option can be configured by following parameters (Figure 39):

- Activation TMO – Time period before Geofence is activated after vehicle stops.
- Deactivate By:
 - Ignition – if ignition becomes high it will drop AutoGeofence Zone
 - iButton – if iButton is attached it will drop AutoGeofence Zone
- Edit iButton List – if list is not empty, attached iButton is tested against iButton list, if match is found AutoGeofence zone is dropped.
- Priority – Priority of generated event, which will be applied to saved record.
- Generate Event:
 - Enter Event – Event generation on Geofence entrance.
 - Exit Event – Event generation on Geofence exit.
 - On Both - Event generation on Geofence entrance or exit.
 - No Event

Auto Geofencing does not require entering coordinates, instead it requires GPS visibility. If vehicle stopped and activation timeout is reached, Auto Geofence will be created around the vehicles last position by set Radius value. Auto Geofence event generation works the same as Geofencing mentioned above.

6.3.6.6 iButton List

iButton list is used to enter authorized iButton ID codes, which are used to authenticate driver in Immobilizer scenario or Auto Geofencing options.

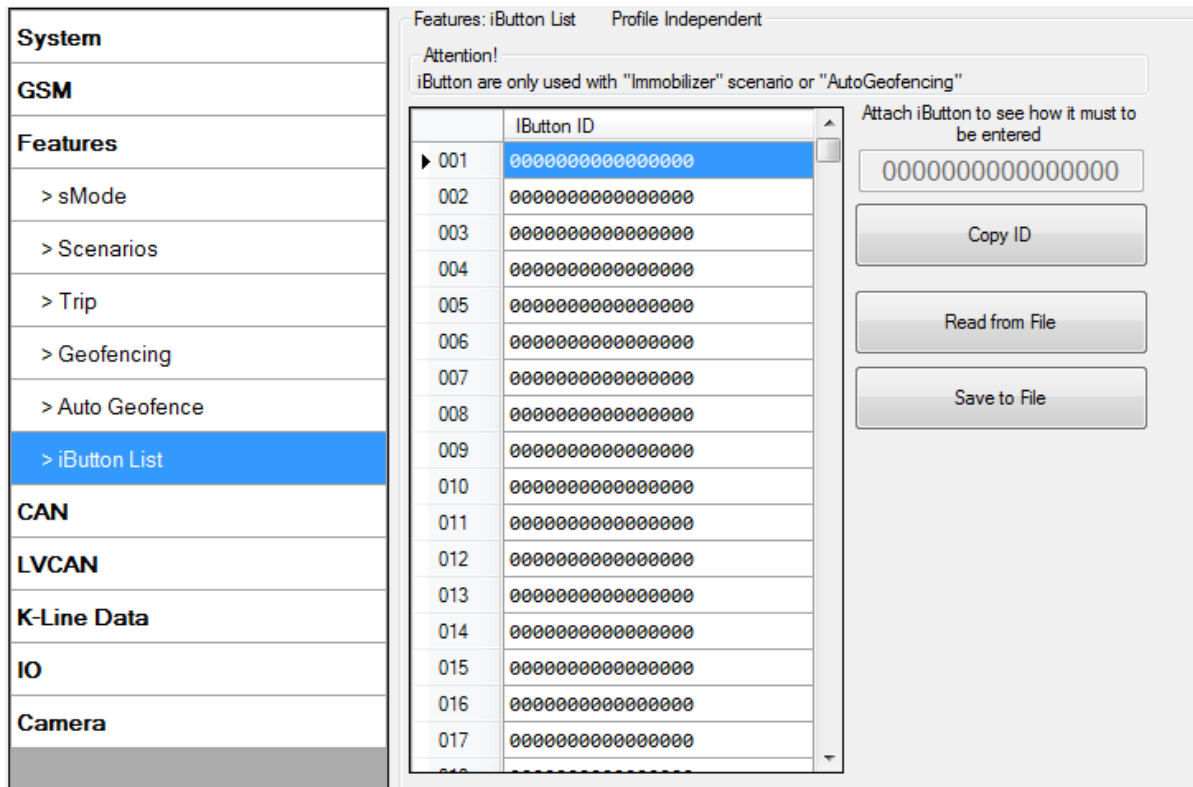

Figure 40 Features->iButton Configuration

iButton value must be entered as it is written on it. User can save 500 iButtons to .csv file and read them from same file using *Read from File* and *Save to File* buttons. User can also enter ibutton key ID in Ibutton ID list by attaching ibutton key to reader then connecting reader to device after that click 'copy ID' and paste ibutton key in ibutton ID list.

6.3.7 CAN

CAN - Controller Area Network (CAN or CAN-bus) is a computer network protocol and bus standard designed to allow microcontrollers and devices to communicate with each other and without a host computer.

6.3.7.1 CAN interface parameters

CAN 1 Enable parameter (ID=146)

Parameter enables or disables CAN 1 interface. Possible values: 0 – disable, 1 – enable.

Table 11 CAN 1 Enable parameter

Minimum value	Maximum value	Recommended value	Value type
0	1	1	U8

CAN 1 Baud Rate (ID=147)

Parameter defines CAN 1 bus baud rate. For Auto Baud rate ID=760 value is 0. Available baud rates are 50, 100, 125, 250, 500 and 1000 kbps.

Table 12 CAN 1 Baud Rate

Minimum	Maximum	Recommended	Value type
---------	---------	-------------	------------

value	value	value	
0	1000	250	U32

CAN 1 operational mode (ID=148)

Parameter defines if CAN 1 line working at silent mode or normal mode. 0 – Silent, 1 – Normal.

Table 13 CAN Baud Rate

Minimum value	Maximum value	Recommended value	Value type
0	1	1	U8

CAN 2 Enable parameter (Used for tachograph) (ID=149)

Parameter enables or disables CAN 2 interface. Possible values: 0 – disable, 1 – enable.

Table 14 CAN 2 Enable parameter

Minimum value	Maximum value	Recommended value	Value type
0	1	1	U8

CAN 2 Baud Rate (ID=150)

Parameter defines CAN 2 bus baud rate. Available baud rates are 250, 500.

Table 15 CAN Baud Rate

Minimum value	Maximum value	Recommended value	Value type
250	500	250	U32

I/O Example:

ManualCAN1:

CAN#0 I/O (ID=x406)

CAN#0 I/O parameter priority

Parameter defines CAN I/O element priority. Enable or Disable.

Table 16 CAN#0 I/O priority

Minimum value	Maximum value	Recommended value	Goes with (depends on) parameters	Value type
0	1	0	CAN#0 I/O CAN Type ID CAN#0 I/O OutputDataMask CAN#0 I/O CAN ID	U8

CAN#0 I/O CAN Type ID

Parameter defines CAN element ID length. CAN element ID could be 11 or 29 bits length. For 11 bits ID parameter value is 0, for 29 bits ID – 1.

Table 17 CAN#0 CAN Type ID

Minimum value	Maximum value	Recommended value	Goes with (depends on) parameters	Value type
0	1	1	CAN#0 I/O Priority CAN#0 I/O OutputDataMask CAN#0 I/O CAN ID	U8

CAN#0 Output data mask

Parameter defines CAN data mask. This parameter is 8 bit length and indicates which data bytes of CAN message are sent for calculation and which are ignored. Bit value 1 means that CAN data byte will be preceded and sent to server.

Example: 00110011 is 51 integer.

Table 18 CAN#0 Output data mask

Minimum value	Maximum value	Recommended value	Goes with (depends on) parameters	Value type
0	255	-	CAN#0 I/O Priority CAN#0 I/O CAN Type ID CAN#0 I/O CAN ID	U8

CAN#0 CAN ID

Parameter defines CAN identifier. ID can be 11 or 29 bits length.

Example: 18FEE925 (total fuel used)

Table 19 CAN#0 CAN ID

Minimum value	Maximum value	Recommended value	Goes with (depends on) parameters	Value type
0	FFFFFFFF	-	CAN#0 I/O Priority CAN#0 I/O CAN Type ID CAN#0 I/O OutputDataMask	U32

To configure CAN#0 I/O element every value above should be separated with comma. For example, SMS should look like:

" setparam 1406 1,0,00110011,18FEE925" (" setparam 1406 <priority>,<CANtypeID>,<outputData Mask>,<CANID>)

*51 is output data mask converted in binary **00110011**

*Above SMS example will configure first profile CAN#0 I/O element with low priority,high level 1,low level 0,logic operand is event on exit,averaging constant is 1,CAN type ID is for 29 bits,output data mask is 51 but must be written after converting in binary,CAN ID is for total fuel used.

The rest CAN elements are configured in the same sequence. CAN elements and parameters ID's are listed below.

Table 20 CAN elements and parameters

Manual CAN 1 Element Number	CAN1 Element parameters	Manual CAN 2 Element Number	CAN2 Element parameters
CAN#0	x406	CAN#0	x504
CAN#1	x407	CAN#1	x505
CAN#2	x408	CAN#2	x506

CAN#3	x409	CAN#3	x507
CAN#4	x410	CAN#4	x508
CAN#5	x411	CAN#5	x509
CAN#6	x412	CAN#6	x510
CAN#7	x413	CAN#7	x511
CAN#8	x414	CAN#8	x512
CAN#9	x415	CAN#9	x513



There are only 14 I/O parameters that could use Averaging Constant: Digital Inputs (1-4); Analog Inputs (1-4); Battery Voltage; Battery Current; External Voltage; PDOP; HDOP; Speedometer.

I/O parameters: "Current Profile", "Fuel level meter" (1-2), "Fuel temperature" (1-2), "GNSS Status", "Network Type", "Movement", "Active GSM Operator", "iButton ID", "Odometer", "GSM Signal", "Deep Sleep", "Cell ID", "Area Code", "PCB Temperature", "Dallas temperature Sensor 0..2", "Fuel Counter" and "RFID ID" cannot use Averaging constant functionality.

6.3.8 I/O

If all I/O elements are disabled AVL packet comes with GPS information only. After enabling I/O element(s) AVL packet in couple with GPS information contains current value(s) of enabled I/O element.

6.3.8.1 FM6320 available I/O list

Table 21 PERMANENT I/O elements list description

Permanent I/O elements (are always sent (with every record) to server if enabled)			
Nr.	Property Name	Bytes	Description
1	Digital Input Status 1	1	Logic: 0 / 1
2	Digital Input Status 2	1	Logic: 0 / 1
3	Digital Input Status 3	1	Logic: 0 / 1
4	Digital Input Status 4	1	Logic: 0 / 1
5	Digital Output Status 1	1	Logic: 0 / 1
6	Digital Output Status 2	1	Logic: 0 / 1
7	Digital Output Status 3	1	Logic: 0 / 1
8	Digital Output Status 4	1	Logic: 0 / 1
9	Analog Input 1	2	Voltage: mV, 0 – 30 V
10	Analog Input 2	2	Voltage: mV, 0 – 30 V
11	Analog Input 3	2	Voltage: mV, 0 – 30 V
12	Profile	1	Value in scale 1 – 4
13	Battery Voltage	2	Voltage: mV
14	Battery Current	2	Voltage: mA
15	GNSS PDOP	2	Probability * 10; 0-500
16	GNSS HDOP	2	Probability * 10; 0-500
17	External Voltage	2	Voltage: mV, 0 – 30 V
18	GNSS status	2	0-off/ 1-no antenna / 2- no fix/ 3-got fix/ 4-sleep/ 5-over current

Permanent I/O elements (are always sent (with every record) to server if enabled)			
Nr.	Property Name	Bytes	Description
19	Movement sensor	1	0 – not moving, 1 – moving.
20	Trip Odometer value	4	Distance between two records: m
21	GSM Operator	4	Currently used GSM Operator code
22	Speed	2	Value in km/h, 0 – xxx km/h
23	iButton ID	8	iButton ID number
24	GSM signal level	2	Value in scale 1 – 5
25	Network Type	1	Logic: 0 / 1
26	Acceleration	1	In mG /10. Acceleration change on X axis * Available since 00.00.54
27	Deceleration	1	In mG /10. Acceleration change on X axis * Available since 00.00.54
28	Cell ID	4	Base station ID. Vvalid CID ranges are from 0 to 65535 on GSM and CDMA networks and from 0 to 268435455 on UMTS and LTE networks.
29	Area Code	2	Location Area code (LAC), it depends on GSM operator. It provides unique number which assigned to a set of base GSM stations. Max value: 65536
30	Deep Sleep	1	0 – not deep sleep mode, 1 – deep sleep mode
31	PCB Temperature	2	10 * Degrees (°C)
32	Dallas ID 1	2	Shows ID of first Dallas sensor
33	Dallas Temperature 1	8	10 * Degrees (°C), -55 - +115, if 3000 – Dallas error
34	Dallas ID 2	2	Shows ID of second Dallas sensor
35	Dallas Temperature 2	8	10 * Degrees (°C), -55 - +115, if 3000 – Dallas error
36	Dallas ID 3	2	Shows ID of third Dallas sensor
37	Dallas Temperature 3	8	10 * Degrees (°C), -55 - +115, if 3000 – Dallas error
38	Dallas ID 4	2	Shows ID of fourth Dallas sensor
39	Dallas Temperature 4	8	10 * Degrees (°C), -55 - +115, if 3000 – Dallas error
40	Dallas ID 5	2	Shows ID of fifth Dallas sensor
41	Dallas Temperature5	8	10 * Degrees (°C), -55 - +115, if 3000 – Dallas error
42	Dallas ID 6	2	Shows ID of sixth Dallas sensor
43	Dallas Temperature 6	8	10 * Degrees (°C), -55 - +115, if 3000 – Dallas error
44	Fuel Counter	4	Difference of generated impulses on two signal lines
45	Ignition	1	0 – ignition is off, 1 – ignition is on
46	RFID COM1	8	Displays activated RFID card ID from COM1
47	Total Odometer	4	Total odometer value km
48	RFID COM2	8	Displays activated RFID card ID from COM2
49	IMSI	8	IMSI code
50	CCID	24	CCID Code
51	LLS #1Fuel	2	Fuel level, measured by LLS sensor on COM2, in kvants or liters.
52	LLS #1 temperature	1	Fuel temperature, measured by LLS sensor on COM2, in degrees Celsius.
53	LLS #2 Fuel	2	Fuel level, measured by LLS sensor on COM2, in kvants or liters.
54	LLS #2 temperature	1	Fuel temperature, measured by LLS sensor on COM2, in degrees Celsius.
55	LLS #3 Fuel	2	Fuel level, measured by LLS sensor on COM2, in kvants or liters.

Permanent I/O elements (are always sent (with every record) to server if enabled)			
Nr.	Property Name	Bytes	Description
56	LLS #3 temperature	1	Fuel temperature, measured by LLS sensor on COM2, in degrees Celsius.
57	LLS #4 Fuel	2	Fuel level, measured by LLS sensor on COM2, in kvants or liters.
58	LLS #4 temperature	1	Fuel temperature, measured by LLS sensor on COM2, in degrees Celsius.
59	LLS #5 Fuel	2	Fuel level, measured by LLS sensor on COM2, in kvants or liters.
60	LLS #5 temperature	1	Fuel temperature, measured by LLS sensor on COM2, in degrees Celsius.

Table 22 EVENTUAL I/O elements list description

Eventual IO elements (generated and sent record to server only if appropriate conditions are met)			
Nr.	Property Name	Bytes	Description
61	CAN1 0	Varying ⁵	ID Specific data
62	CAN1 1	Varying	ID Specific data
63	CAN1 2	Varying	ID Specific data
64	CAN1 3	Varying	ID Specific data
65	CAN1 4	Varying	ID Specific data
66	CAN1 5	Varying	ID Specific data
67	CAN1 6	Varying	ID Specific data
68	CAN1 7	Varying	ID Specific data
69	CAN1 8	Varying	ID Specific data
70	CAN1 9	Varying	ID Specific data
71	CAN2 0	Varying ⁶	ID Specific data
72	CAN2 1	Varying	ID Specific data
73	CAN2 2	Varying	ID Specific data
74	CAN2 3	Varying	ID Specific data
75	CAN2 4	Varying	ID Specific data
76	CAN2 5	Varying	ID Specific data
77	CAN2 6	Varying	ID Specific data
78	CAN2 7	Varying	ID Specific data
79	CAN2 8	Varying	ID Specific data
80	CAN2 9	Varying	ID Specific data
81	Geofence zone 01	1	Event: 0 – target left zone, 1 – target entered zone
82	Geofence zone 02	1	Event: 0 – target left zone, 1 – target entered zone
83	Geofence zone 03	1	Event: 0 – target left zone, 1 – target entered zone
84	Geofence zone 04	1	Event: 0 – target left zone, 1 – target entered zone
85	Geofence zone 05	1	Event: 0 – target left zone, 1 – target entered zone
86	Geofence zone 06	1	Event: 0 – target left zone, 1 – target entered zone
87	Geofence zone 07	1	Event: 0 – target left zone, 1 – target entered zone
88	Geofence zone 08	1	Event: 0 – target left zone, 1 – target entered zone
89	Geofence zone 09	1	Event: 0 – target left zone, 1 – target entered zone
90	Geofence zone 10	1	Event: 0 – target left zone, 1 – target entered zone

⁵ CAN property length can vary depending on filter settings. Data can be sent as 1, 2, 4 or 8 byte property.

⁶ CAN property length can vary depending on filter settings. Data can be sent as 1, 2, 4 or 8 byte property.

Eventual IO elements (generated and sent record to server only if appropriate conditions are met)			
Nr.	Property Name	Bytes	Description
91	Geofence zone 11	1	Event: 0 – target left zone, 1 – target entered zone
92	Geofence zone 12	1	Event: 0 – target left zone, 1 – target entered zone
93	Geofence zone 13	1	Event: 0 – target left zone, 1 – target entered zone
94	Geofence zone 14	1	Event: 0 – target left zone, 1 – target entered zone
95	Geofence zone 15	1	Event: 0 – target left zone, 1 – target entered zone
96	Geofence zone 16	1	Event: 0 – target left zone, 1 – target entered zone
97	Geofence zone 17	1	Event: 0 – target left zone, 1 – target entered zone
98	Geofence zone 18	1	Event: 0 – target left zone, 1 – target entered zone
99	Geofence zone 19	1	Event: 0 – target left zone, 1 – target entered zone
100	Geofence zone 20	1	Event: 0 – target left zone, 1 – target entered zone
101	Auto Geofence	1	Event: 0 – target left zone, 1 – target entered zone
102	Trip	1	1 – trip start, 0 – trip stop
103	Immobilizer	1	1 – iButton connected
104	Authorized driving	1	1 – authorized iButton connected
105	ECO driving/Green driving type	1	1 – harsh acceleration, 2 – harsh braking, 3 - harsh cornering
106	ECO driving/Green driving value	1	Depending on ECO driving/Green driving type: if harsh acceleration, braking and cornering – $g \cdot 10 \text{ m/s}^2$
107	Over Speeding	1	At over speeding start km/h, at over speeding end km/h
108	Excessive idling	1	1- idling detected, 0- idling ended
109	Jamming detection	1	1 – jamming start, 0 – jamming stop
110	Crash detection	1	1 – crash event occurred



There are two types of operations with Permanent I/O elements: simple monitoring and event generating. Monitoring method is used when current I/O information needed with regular GPS coordinates. Event generating method is used when additional AVL packet is needed when current value of I/O exceeds predefined High and Low levels. I/O settings allow defining I/O event criteria.

6.3.8.2 I/O configuring

I/O configuration has 7 main parts (Figure 41)

System	I/O						
	Property Input	<input type="checkbox"/> Enabled	Priority	LowLevel	HighLevel	GenerateEvent	Averaging Constant
GSM	Digital input 1	<input type="checkbox"/>	Disabl	0	0	On Both	10
Features	Digital input 2	<input type="checkbox"/>	Disabl	0	0	Monitoring	10
CAN	Digital input 3	<input type="checkbox"/>	Disabl	0	0	Monitoring	10
LVCAN	Digital input 4	<input type="checkbox"/>	Disabl	0	0	Monitoring	10
K-Line Data	Digital output 1	<input type="checkbox"/>	Disabl	0	0	Monitoring	10
IO	Digital output 2	<input type="checkbox"/>	Disabl	0	0	Monitoring	10
	Digital output 3	<input type="checkbox"/>	Disabl	0	0	Monitoring	10
	Digital output 4	<input type="checkbox"/>	Disabl	0	0	Monitoring	10
	Analog input 1	<input type="checkbox"/>	Disabl	0	0	Monitoring	10
	Analog input 2	<input type="checkbox"/>	Disabl	0	0	Monitoring	10
	Profile	<input type="checkbox"/>	Disabl	0	0	Monitoring	10
	Battery Voltage	<input type="checkbox"/>	Disabl	0	0	Monitoring	10
	Battery Current	<input type="checkbox"/>	Disabl	0	0	Monitoring	10
	GNSS PDOP	<input type="checkbox"/>	Disabl	0	0	Monitoring	10
	GNSS HDOP	<input type="checkbox"/>	Disabl	0	0	Monitoring	10
	External voltage	<input type="checkbox"/>	Disabl	11000	30000	Monitoring	10
	Gnss Status	<input type="checkbox"/>	Disabl	0	0	Monitoring	
	Movement sensor	<input type="checkbox"/>	Disabl	0	0	On Exit	10
	Odometer value	<input type="checkbox"/>	Disabl	0	0	Monitoring	
	GSM operator	<input type="checkbox"/>	Disabl	0	0	Monitoring	
	Speed (km/h)	<input type="checkbox"/>	Disabl	0	0	Monitoring	10
	iButton ID	<input type="checkbox"/>	Disabl	0	0	Monitoring	10
	GSM signal level	<input type="checkbox"/>	Disabl	0	0	Monitoring	10
	Deep sleep	<input type="checkbox"/>	Disabl	0	0	Monitoring	
	PCB Temperature	<input type="checkbox"/>	Disabl	0	0	Monitoring	10

Figure 41 FM6320 I/O Configuration (1)

Table 23 I/O Configuration window description

Pos. Nr.	DESCRIPTION
1.	Property inputs list
2.	Enable/Disable chosen property input - allows enabling I/O element so it is added to the data packet and is sent to the server. By default, all I/O elements are disabled and FM6320 records only GPS information.
3.	Priority - AVL packet priority. There are Low, High, Panic, SW21, SW22, SW23 and SW24 priorities. Regular packets are sent as Low priority records. When low priority event is triggered, FM6320 makes additional record with indication that the reason for that was I/O element change. When High priority is selected, module makes additional record with high priority flag and sends event packet immediately to the server. First it tries to send it using GPRS. If GPRS fails, it doesn't send AVL packet using SMS mode, if SMS is enabled in SMS settings. Panic priority event forces module to send AVL packet to server via GPRS and if GPRS fails, it sends AVL packet using SMS mode, if SMS is enabled in SMS settings. Then it switches its operating profile to Profile 4 (for details see chapter 7.2). SW2X priorities switch profiles on event (SW21 – Profile 1, SW22 – Profile 2 and so on).
4.	High Level - define I/O value range. If I/O value enters or exits this range, FM6320 generates event.
5.	Low Level – define I/O value range. If I/O value enters or exits this range, FM6320 generates event.
6.	Generate event – defines when to generate event. When value enters defined range, exits it or both enters and exits.
7.	Averaging Constant – it is an I/O event delay parameter. In some applications there is no need to generate events on every I/O range enter/exit immediately. Sometimes it is necessary to wait some time interval before event generating to be ensuring that

Pos. Nr.	DESCRIPTION
	<p>current event is not a short time event. Averaging constant allows setting I/O event delay (averaging). If I/O value is entering or leaving predefined range, it must have same value for Averaging constant time. One unit of averaging constant value equals 100 milliseconds.</p> <p>Selected data source value input averaging constant are calculated by following formula:</p> $VAL^{Mean} = \frac{VAL^{Mean-1} \times (CONST - 1) + REALVAL}{CONST}$ <p>Where: VAL^{Mean} – Value calculated during actual cycle⁷; VAL^{Mean-1} – Value calculated during previous cycle; CONST – Averaging constant; REALVAL – Real value detected on digital input.</p>

6.3.8.3 I/O properties

I/O properties are additional data sources, which are recorded along with usual GPS data.

IO#0 (ID=x300)

I/O#0 priority

Parameter defines I/O property type of priority: 0 is disabled, 1 is low, 2 – high, 3 – panic, 4 – SW21, 5 – SW22, 6 – SW23, 7 –SW24.

Table 24 I/O Type of Priority

Minimum value	Maximum value	Recommended value	Goes with (depends on) parameters	Value type
0	7 (ex. 3)	0	I/O#0 property parameter I/O#0 High level I/O#0 Low level I/O#0 logic operand I/O#0 averaging constant	S8

I/O#0 High level

Parameter defines high value of triggered I/O property. This parameter is used to set thresholds for I/O properties to generate events.

Table 25 I/O High Value

Minimum value	Maximum value	Recommended value	Goes with (depends on) parameters	Value type
0	9999999	1	I/O#0 property parameter – priority I/O#0 Low level I/O#0 logic operand	S32

⁷ One cycle equal to 100 ms.

			I/O#0 averaging constant	
--	--	--	--------------------------	--

I/O#0 Low level

Parameter defines low value of triggered I/O property. This parameter is used to set thresholds for I/O properties to generate events.

Table 26 I/O Low Value

Minimum value	Maximum value	Recommended value	Goes with (depends on) parameters	Value type
0	9999999	0	I/O#0 property parameter – priority I/O#0 High level I/O#0 logic operand I/O#0 averaging constant	S32

I/O#0 logic operand

Parameter defines when event is sent: 0 is event on exit, 1 – on entrance, 2 – on both, 3 – monitoring, 4 – hysteresis, 5 – on change.

Table 27 I/O Logic Operand

Minimal value	Maximum value	Recommended value	Goes with (depends on) parameters	Value type
0	5	2	I/O#0 priority I/O#0 High level I/O#0 Low level I/O#0 averaging constant IO#0 (ID=x300)	S8

I/O#0 averaging constant

Parameter defines I/O property sample length to average. If no averaging needed default value is 10.

Table 28 I/O Averaging constant

Minimum value	Maximum value	Recommended value	Goes with (depends on) parameters	Value type
1	99999999	1	IO#0 (ID=x300) I/O#0 priority I/O#0 High level I/O#0 Low level I/O#0 logic operand	S32

To configure I/O#0 element every value above should be separated with comma. For example, configuring first profile I/O#0 element by SMS, SMS should look like: “ **setparam 1300 1,0,0,1,1**” (“ setparam 1300 <priority>,<HighLevel>,<LowLevel>,<Operand>,<AvgConstant>”)

Other I/O property elements can be configured in the same logic. All I/O element parameters are listed below.

Table 29 I/O Elements

I/O Element Number	I/O element parameters	I/O Element Number	I/O element parameters
I/O#0 – Digital input 1	x300	I/O#29 – PCB Temp.	x324
I/O#1 – Digital input 2	x301	I/O#30 – Dallas ID 1	x325
I/O#2 – Digital input 3	x302	I/O#31 – Dallas Temp. 1	x326
I/O#3 – Digital input 4	x303	I/O#32 – Dallas ID 2	x327
I/O#4 – Digital output 1	x304	I/O#33 – Dallas Temp. 2	x328
I/O#5 – Digital output 2	x305	I/O#34 – Dallas ID 3	x329
I/O#6 – Digital output 3	x306	I/O#35 – Dallas Temp. 3	x330
I/O#7 – Digital output 4	x307	I/O#36 – Dallas ID 4	x331
I/O#8 – Analog input 1	x308	I/O#37 – Dallas Temp. 4	x332
I/O#9 – Analog input 2	x309	I/O#38 – Dallas ID 5	x499
I/O#10 – Analog input 3	X445	I/O#39 – Dallas Temp. 5	x500
I/O#10 – Profile	x310	I/O#40 – Dallas ID 6	x501
I/O#11 – Battery voltage	x311	I/O#41 – Dallas Temp. 6	x502
I/O#12 – Battery Current	x312	I/O#42 – Fuel Counter	x333
I/O#13 – GPS PDOP	x313	I/O#43 – Ignition	x334
I/O#14 – GPS HDOP	x314	I/O#44 – RFID ID	x335
I/O#15 – Ext. Voltage	x315	I/O#45 – Total Odometer	x519
I/O#16 – GNSS Status	x316	I/O#46 – RFID COM2	x520
I/O#17 – Movement sensor	x317	I/O#47 – IMSI code	x524
I/O#18 – Odometer value	x318	I/O#48 – CCID code	x525
I/O#19 – GSM Operator	x319	I/O#49 – LLS #1 temp.	x336
I/O#20 – Speed	x320	I/O#50 – LLS #1 meter	x337
I/O#21 – iButton ID	x321	I/O#51 – LLS #2 temp.	x338
I/O#22 – GSM Signal level	x322	I/O#52 – LLS #2 meter	x339
I/O#23 – Network Type	x447	I/O#53 – LLS #3 temp.	x340
I/O#24 – Acceleration	x448	I/O#54 – LLS #3 meter	x341
I/O#25 – Deceleration	x449	I/O#55 – LLS #4 temp.	x342
I/O#26 – Cell ID	x450	I/O#56 – LLS #4 meter	x343
I/O#27 – Area Code	x451	I/O#57 – LLS #5 temp.	x344
I/O#28 – Deep Sleep	x323	I/O#58 – LLS #5 meter	x345

6.3.8.4 K Line parameters

Table 30 K line elements and parameters

Name	Parameter Name	Configuration ID	Available Values
KLINE Driver Recognize	Priority	X050*	0 – disable 1 – low 2 – high
	High level		N/A
	Low level		N/A
	Generate event		3 – Monitoring

Name	Parameter Name	Configuration ID	Available Values
			5 – On change
KLINE Driver 1 working state	Priority	X051*	0 – disable 1 – low 2 – high
	High level		N/A
	Low level		N/A
	Generate event		3 – Monitoring 5 – On change
KLINE Driver 2 working state	Priority	X052*	0 – disable 1 – low 2 – high
	High level		N/A
	Low level		N/A
	Generate event		3 – Monitoring 5 – On change
KLINE Overspeed	Priority	X053*	0 – disable 1 - low 1 – high
	High level		N/A
	Low level		N/A
	Generate event		3 – Monitoring 5 – On change
KLINE Driver 1 card	Priority	X054*	0 – disable 1 – low 2 – high
	High level		N/A
	Low level		N/A
	Generate event		3 – Monitoring 5 – On change
KLINE Driver 2 card	Priority	X055*	0 – disable 1 – low 2 – high
	High level		N/A
	Low level		N/A
	Generate event		3 – Monitoring 5 – On change
KLINE Driver 1 rel time states	Priority	X056*	0 - disable 1 – low 2 – high
	High level		N/A
	Low level		N/A
	Generate event		3 – Monitoring 5 – On change
KLINE Driver 2 rel time states	Priority	X057*	0 – disable 1 – low 2 – high

Name	Parameter Name	Configuration ID	Available Values
	High level		N/A
	Low level		N/A
	Generate event		3 – Monitoring 5 – On change
KLINE Vehicle speed	Priority	X058*	0 – disable 1 – low 2 – high
	High level		0 – 255 km/h
	Low level		0 – 255 km/h
	Generate event		0 – On range exit 1 – On range entrance 2 – On both 3 – Monitoring 4 – Hysteresis 5 – On change
KLINE Odometer	Priority	X059*	0 – disable 1 – low 2 – high
	High level		N/A
	Low level		N/A
	Generate event		3 – Monitoring 5 – On change
KLINE Distance	Priority	X060*	0 – disable 1 – low 2 – high
	High level		N/A
	Low level		N/A
	Generate event		3 – Monitoring 5 – On change
KLINE Tacho Timestamp	-	X061*	-
KLINE Driver 1 ID	Priority	X062*	0 – disable 1 – low 2 – high
	High level		N/A
	Low level		N/A
	Generate event		3 – Monitoring 5 – On change
KLINE Driver 2 ID	Priority	X063*	0 – disable 1 – low 2 – high
	High level		N/A
	Low level		N/A
	Generate event		3 – Monitoring 5 – On change

* X – Profile number 1/2/3/4

To configure any K Line parameter, every parameter should be separated with comma. For example, configuring first profile Kline Driver 2 ID by SMS, SMS should look like: “ **setparam 1062 1,,,3**” (“ setparam 1062 <Priority>,<HighLevel>,<LowLevel>,<generateEvent>”) Driver 2 ID does not have High/Low level so they are skipped by using comma “,,” Other Kline properties can be configured in the same logic.

6.3.8.5 Configurable parameter values and Global parameter values

Configurable parameters:

Table 31 Configurable parameter values

Parameter	ID	Parameter value				Value type	
		MIN	MAX	Default	Recommended		
System settings (6.3.4)							
Sleep Mode							
0	Disable	x000	0	2	0	-	U8
1	Enable						
2	Deep sleep						
Sleep Timeout		x001	0	9000	1	-	U16
Ignition source							
0	Power voltage	x900	0	5	0	-	U8
1	Din 1						
2	Din 2						
3	Din 3						
4	Din 4						
5	Movement						
High Voltage Level (for Ignition)		x901	0	30000	0	-	U16
Low Voltage Level (for Ignition)		x902	0	30000	0	-	U16
GPRS data sending settings (6.3.5.1)							
GPRS Context Activation		x240	0 (Disable)	1 (Enable)	0	-	S8
Domain or IP			Empty	56 char	Empty	-	-
Target Server Port			0	65535	0	-	U16
Protocol			0 (TCP)	1 (UDP)	0	-	U8
Server Response Timeout			5	300	5	-	U16
Configuring format:		<Enable>,<Domain/IP>,<port>,<protocol>,<Server Reponse Tmo>					
GPRS data limit settings (6.3.5.2)							
Enable GPRS limits		x241	0 (Disable)	1 (Enable)	0	-	U8
Data limit Home			1	10000	100	-	U16
Data limit Roaming			1	10000	10	-	U16
Configuring format:		<Enable>,<Data Limit Home>,<Data Limit Roaming>					
SMS security settings (6.3.5.3)							
SMS Login		x252	Empty	5 char	Empty	-	S8[5]
SMS Password		x253	Empty	5 char	Empty	-	S8[5]
Authorized phone numbers		x260-x269	Empty	16 char	Empty	-	S8[17]

Parameter	ID	Parameter value				Value type
		MIN	MAX	Default	Recommended	
SMS data sending settings (6.3.5.4)						
SMS Data	x250	0 (Disable)	1 (Enable)	0	-	U8
SMS Data send week time schedule	x273	Binary decoding	Binary decoding	-	-	20 byte array
Configuring format:	<x1>,<x2>,<x3>,<x4>.....<x19>					
Operator list settings (6.3.5.6)						
Preferred Operator	x271	0	99999999	0	-	U32
Black List Operator	x272	0	99999999	0	-	U32
Configuring format: (setparam Y271 X)	X is start position. If no X is set starts from 0 Max 19 operator codes can be set (separated by comma) in one SMS command.					
Reading format: (getparam Y271 X)	X values can be 1,2,3. If X = 1, Operator codes from 0-19 are read from configuration and sent via SMS. If X = 2, Operator codes from 20-39 are read from configuration and sent via SMS. If X = 3, Operator codes from 40-49 are read from configuration and sent via SMS. If X = any other, Operator codes from 0-19 are read from configuration and sent via SMS *User must use X, without X value device responds that parameter is wrong or it can respond with wrong operator codes.					
Data Acquisition settings (Chapter 9)						
Data acquisition modes	x010					
Min Period (in seconds)		0	99999999	600	-	U32
Min Distance (in meters)		0	65535	0	-	U32
Min Angle (in degrees)		0	180	0	-	U16
Min Speed (in km/h)		0	400	0	-	U16
Min Speed Source		0 (from GPS)	1 (from LVCAN)	0	-	U8
Min Saved Records		1	25	10	1	U8
Min Send Period (in seconds)		0	99999999	600	-	U32
Configuring format:	<minperiod>,<mindistance>,<minangle>,<minspeed>,<minspeedsource>,<minsavedrec>,<sendperiod>					
GPRS Week Time	x016	-	-	-	-	-
Configuring format:	<x1>,<x2>,<x3>,<x4>.....<x19>					
Geofencing settings (6.3.6.4)						
Frame Border (in meters)	x020	0	99999999	1	1000	U32
Geofence Overspeed control	x021	0	5	0	-	U8
Geofence Zone #1	x030					
Zone #1 Shape		0 (Circle)	1 (Rectangle)	0	-	U32
Zone #1 priority		0	7 (exl. 3)	0	-	U8
0		Low				
1		High				
2	Panic					
4	SW21					

Parameter		ID	Parameter value				Value type
			MIN	MAX	Default	Recommended	
5	SW22						
6	SW23						
7	SW24						
Zone #1 Generate Event							
0	No Event						
1	On enter		0	3	0	-	U8
2	On exit						
3	On both						
Min Angle (in degrees)			0	180	0	-	U16
Zone #1 Longitude X1 (Rectangle) / X (Circle)			-180	180	0	-	Float
Zone #1 Longitude X2 (Rectangle) / R (Circle)			-180	180	0	-	Float
Zone #1 Latitude Y1 (Rectangle) / Y (Circle)			-90	90	0	-	Float
Zone #1 Latitude Y2 (Rectangle) / None (Circle)			-90	90	0	-	Float
Zone #1 Longitude X2 (Rectangle) / R (Circle)			-180	180	0	-	Float
Zone #1 Latitude Y2 (Rectangle) / None (Circle)			0	180 / 9999999.99	0	0	Float
Geofencing overspeeding value			-90	90	0	-	Float
			0	250	0	-	U16
Configuring format:		<shape>,<priority>,<generateEvent>,<fx1>,<fy1>,<fx2>,<fy2>,<geo_overspeed_val>					
Geofence Zone #2	x031	Same configuration as Geofence Zone #1					
Geofence Zone #3	x032						
Geofence Zone #4	x033						
Geofence Zone #5	x034						
Geofence Zone #6	x035						
Geofence Zone #7	x036						
Geofence Zone #8	x037						
Geofence Zone #9	x038						
Geofence Zone #10	x039						
Geofence Zone #11	x040						
Geofence Zone #12	x041						
Geofence Zone #13	x042						
Geofence Zone #14	x043						
Geofence Zone #15	x044						
Geofence Zone #16	x045						
Geofence Zone #17	x046						
Geofence Zone #18	x047						
Geofence Zone #19	x048						
Geofence Zone #20	x049						
Auto Geofencing settings (6.3.6.5)							
Autogeofence	x290						
Deactivate By		0 (Ignition)	1 (iButton)	0	-	U8	
Activation Timeout (in seconds)		0	65535	60	60	U16	

Parameter	ID	Parameter value				Value type	
		MIN	MAX	Default	Recommended		
Min Angle (in degrees)		0	180	0	-	U16	
Zone #1 priority							
0	Low						
1	High						
2	Panic						
4	SW21						
5	SW22						
6	SW23						
7	SW24						
Zone #1 Generate Event							
0	No Event						
1	On enter						
2	On exit						
3	On both						
Radius (in meters)		0	9999999	100	100	U32	
Configuring format:	<deactivateBy>,<tmo>,<priority>,<eventGenerating>,<radius>						
Eco/Green driving settings (Chapter 12.1)							
Eco driving type		x910					
0	Disable						
1	No DOUT control						
2	DOUT1 control						
3	DOUT2 control		0	5	0	-	U8
4	DOUT3 control						
5	DOUT4 control						
Eco source			0 (accelerometer)	1 (GPS)	0	-	U8
Max Acceleration Force			5	100	22	25	Float
Max Braking Force			5	100	25	35	Float
Max Cornering Force		5	100	21	-	Float	
Acceleration Active Output Duration		0	100	1	-	Float	
Braking Active Output Duration		0	100	1	-	Float	
Cornering Active Output Duration		0	100	1	-	Float	
Configuring format:	<Eco driving type>,<Ecosource><MaxAcceleration>,<MaxBraking>,<MaxCornering>,<AccOutputDuration>,<BrakingOutputDuration>,<CorneringOutputDuration>						
Overspeeding settings (Chapter 12.2)							
Overspeeding mode		x911	0	5	0	-	U8
0	Disable						
1	No DOUT control						

Parameter		ID	Parameter value				Value type
			MIN	MAX	Default	Recommended	
2	DOUT 1 control						
3	DOUT 2 control						
4	DOUT 3 control						
5	DOUT 4 control						
Max Allowed Speed			0	300	90	-	
Configuring format:		<Overspeeding mode>,<MaxSpeed>					
Immobilizer settings (Chapter 12.3)							
Immobilizer mode		x912	0	5	0	-	U8
0	Disable						
1	No DOUT						
2	DOUT1 control						
3	DOUT2 control						
4	DOUT3 control						
5	DOUT4 control						
iButton List checking		0 (Disable)	1 (Enable)	0	-	U8	
Ignition Timeout		1	255	30	-	U16	
Configuring format:		<ImmobMode>,<button_enable>,<TMO>					
Excessive Idling settings (Chapter 12.4)							
Excessive Idling		x913	0 (Disable)	1 (Enable)	0	-	U8
Time to stationary			0	255	1	-	U16
Time to movement			0	255	1	-	U16
Configuring format:		<Enable>,<Time to stationary>,<Time to movement>					
Jamming settings (Chapter 12.5)							
Jamming Detection		x914	0	5	0	-	U8
0	Disable						
1	No DOUT						
2	DOUT1 control						
3	DOUT2 control						
4	DOUT3 control						
5	DOUT4 control						
Sensitivity		1 (low)	3 (High)	0	-	U8	
Timeout		1	255	60			
Dout duration		1	255	0	-	U16	
Configuring format:		<Enable>,<Sensitivity>,<Start_TMO>,<DOUT_duration_TMO>					
iButton Notification settings (Chapter 12.6)							

Parameter	ID	Parameter value				Value type	
		MIN	MAX	Default	Recommended		
iButton notification	x915	0	5	0	-	U8	
0							Disable
1							No DOUT control
2							DOUT1 control
3							DOUT2 control
4							DOUT3 control
5		DOUT4 control					
iButton Notification		0 (Disable)	1 (No dout control)	0	-	U8	
Timeout		1	65530	0	-	U16	
Configuring format:	<Enable/Dout control>,<DOUT TMO>						
Crash Detection settings (12.7)							
Scenario			0 (Disable)	1 (Enable)	0	-	U8
Acceleration Threshold			16	8000	4000	-	U8
Configuring format:	<Scenario>,<Threshold>						
Trip settings (6.3.6.3)							
Trip	x280	0 (Disable)	1 (Enable)	0	-	U8	
Start Speed		0	255	5	-	U8	
Ignition Off Timeout		0	65536	60	-	U16	
Remember iButton ID, while Trip detected		0 (Disable)	1 (Enable)	0	-	U8	
Configuring format:	<Enable>,<StartStopSpeed>,<IgnitionOffTimeout>,<remember iButton>						

This parameter manages when it is allowed to open GPRS context. When module starts it is prohibited to open the context. When modem's GPRS context is closing (for example changing network) it is allowed to open it only at a defined time. It is possible to allow connections every 10 minutes up to once per day.

Example value: 7F,FF,FF,FF,FF,FF,FF,FF,FF,FF,FF,FF,FF,FF,FF,FF,FF,FF,FF,FF

Schedule parameter format:

Time is defined as 19 byte array ('getparam' 1545 returns 20 bytes). First byte of array defines week days; the rest 18 bytes define timestamps with 10 minute interval. In first byte, first bit (LSB) defines if module should connect to GPRS (send SMS) on Monday, second bit – on Tuesday and so on up to seventh bit – which means Sunday. Eighth bit (MSB) is not used. If bits value is 0 then device is not allowed to open GPRS context, but if it is already open – does not close it. If value is 1 it will work as day minutes are defined in rest of the bytes. Day's minutes are defined by 18 bytes (144 bits). Every nth bit (beginning from the first bit (LSB) and ending 18 bytes 8th bit (MSB)) indicates every 10th minute of the day (day has 1440 minutes).

Sample: GPRS will be allowed on Monday to Friday at 8:00 and 16:00 GMT. The following value should be configured:

00011111 00000000 00000000 00000000 00000000 00000000 00000000 00000001 00000000 00000000
 00000000 00000000 00000000 00000001 00000000 00000000 00000000 00000000 00000000

Red bits indicate that GPRS will be allowed every day except Saturdays and Sundays. Blue bits indicate 480 and 720 minutes (480min = 8h and 720min = 16h). So the parameter value should be: 1F,00,00,00,00,00,00,01,00,00,00,00,00,01,00,00,00,00,00

It should be sent as UTF8 encoded string.

Global and External devices parameters:

Table 32 Global parameters values

Parameter	ID	Possible Parameter Value	Default Value
Profile Change On Event	100	0/1 (0 – disable, 1 – enable, 2 – Dual SIM)	0
Preferred records saving destination	101	0/1 (0 – internal memory, 1 – SDcard)	10
Analog Input 1-2 Type	105	0/1 (0 – 10 V, 1 – 30 V)	0
Static Navigation On/Off	107	0/1 (0 – disable, 1 – enable)	1
Records Sorting	108	0/1 (0 – from newest, 1 – from oldest)	0
Active Data Link Timeout	109	0 – 259200 (time in seconds)	5
Accelerometer Filter Start Value	112	1 – 10 (time in seconds)	1
Accelerometer Filter Stop Value	113	1 – 255 (time in seconds)	30
Total Odometer	114	0/1/2/3/4 (0 – GPS, 1 – LVCAN, 2-ALLCAN, 3-FMS, 4-KLINE)	0
J1708 Enable parameter	115	0/1 (0 – GPS, 1 – LVCAN, 2 – ALLCAN, 3 -FMS, 4 -Kline)	0
GNSS Satellite System	116	0/1/2/3/4 (0 – all available, 1 – GPS, 2 – GLONASS, 3 – GNSS (all available) + SBAS, 4 – GPS + SBAS)	0
Garmin Ping	117	0/1 (0 – disable, 1 – enable)	0
Garmin Unicode	118	0/1 (0 – disable, 1 – enable)	1
Com1 baudrate	119	0 – 115200	
COM1 Mode	120	0-255 (5 - Silent, 13 – FM Log, 97 – LLS Mode, 98 – LCD Mode, 99 – RFID Mode, 100 – RFID MF7 Mode, 101 – Garmin Mode, 161 – COM TCP Link Mode, 177 – COM TCP Link Mode Binary, 201 – Records to LCD mode, 10-11 – reserved)	0
GNSS TMO For NTP	121	0-300	0
COM2 Baudrate	122	0 – 115200	5
COM2 Mode	124	0 – 255 (5 - Silent, 13 - FM Log, 15 – NMEA, 97 - LLS, 98 - LCD, 99 - RFID, 100 - RFID M7, 101 - Garmin, 161 - COM TCP Link, 177 - COM TCP Link binary, 201 – Records to LCD mode)	115200
COM1 Timestamp	151	0/1 (0 – disable, 1 – enable)	0
COM1 CMD ID	152	0 – 100	0
COM2 Timestamp	153	0/1 (0 – disable, 1 – enable)	10
COM2 CMD ID	154	0 – 100	3
Network Ping Timeout	155	0 – 30 (time in minutes)	0

Parameter	ID	Possible Parameter Value	Default Value
Data saving without time synchronization	157	0/1 (0 – disable, 1 – enable)	0
Tachograph ignition source	158	1/2/3/4	3
SMS Event number	222-231	string	„“
RS485 Activate	232	0/1	0
RS485 Baudrate	233	0 – 115200	115200
RS485 Mode	234	0 – 255 (5 – Silent, 13 – Log mode, 15 – NMEA, 97 – LLS Mode, 161 – TCP link mode, 171 – Binary mode)	5
SIM1 GPRS APN	240	All character range	
SIM1 GPRS USER	241	All character range	
SIM1 GPRS PASS	242	All character range	
SIM2 GPRS APN	243	All character range	
SIM2 GPRS USER	244	All character range	
SIM2 GPRS PASS	245	All character range	
LLS 1-5	256-260	0,255	0
SMS event data min-max	300-499	SMS Events	
Tachograph device	159	0 - DTC0 1381, 1 - SE5000	0
webDDD	160	0/1 (0 – disable, 1 – enable)	0
webDDD domain	161	Maximum 56 Char	Empty
webDDD port	162	0 - 65535	0
iButton List	500-999	0 - FFFFFFFF	0

Configuring SMS event by SMS there is special SMS format:

SMS Format: setparam X Y,W,Z

X – ID

Y – Enable/Disable (1/0)

W – Telephone number INDEX (0 – 9)

Z – SMS Text

Example: “ setparam 300 1,5,Digital Input 1 Event!”

7 PROFILE SWITCHING

FM6320 has 4 profiles saved in Flash memory of the module. Every profile has a list of parameters, which enables FM6320 to operate in different modes while using different profiles. The easiest way to understand what is a profile is to compare it to a list of instructions that are written for different cases. You are allowed to setup up to 4 different module behaviours. Global parameters and external devices contain settings that are common for all 4 profiles. This means that if you set FM6320 to call to a predefined number, you will be able to call it while using any

profile. Basic scheme of Global parameters, external devices and profiles is shown below. According to the scheme, every profile has a list of parameters. Global parameters and external devices are common for all profiles. (Figure 42)

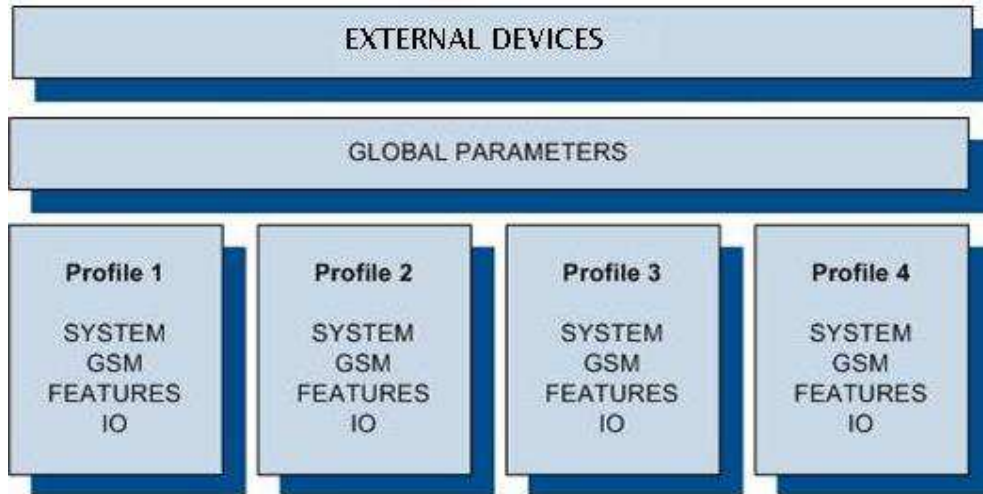

Figure 42 FM6320 profile structure

Switching between profiles (changing behaviour) can be performed by Profile switch depending on GSM operator code (mostly used for roaming applications), or by Profile switch depending on I/O event (on I/O value changing).

Profile 3 is default profile for FM6320. It is always loaded on the very first start-up and further profile switching is proceeded after operator scan or I/O element changes (although device remembers which profile it used after that).

7.1 Profile Switching dependence on GSM Operator

GSM Operator code profile switching is mostly used in roaming applications, when the purpose is to have information from module both from Home and Roaming operator network for a reasonable price. This method allows you to define different module behaviour in Home network, Roaming network and unknown operator areas. See Figure 43 below for details.

Profile 1 is configured for home network. Data acquisition and send intervals are quite frequent here. To make profile use effective, it is wise to set more optimized parameters in roaming profile (Profile 2) – this usually includes larger coordinate recording intervals, packets with greater number of coordinates sending, and in some cases GPRS context available only for a certain time interval. Profile 3 can either contain operator codes (rarely used) or have an empty list. Profile 4 is not used (profile 4 can only be used when FM6320 encounters a 'panic' priority event (see Chapter 7)).

In the example (Figure 43) FM6320 connects to operator with code 24702. It checks profile 1 operator list, but there is only one operator code entered which does not mach. Then it checks profile 2 operators list. This code is entered there, so FM6320 switches to profile 2.

If there are no operator codes entered in all profiles after operator search task FM6320 will check all 3 profiles and won't find any operators in any list. In such a case, FM6320 will switch to profile 3. Note that before switching to profile 3, the device closes the GPRS session.



Operator search is performed every 15 minutes. If no operators are entered in any profile it can have influence on GPRS sessions. IF GPRS sessions are attaching/detaching every 15 minutes it means configuration of FM6320 is performed incorrectly.

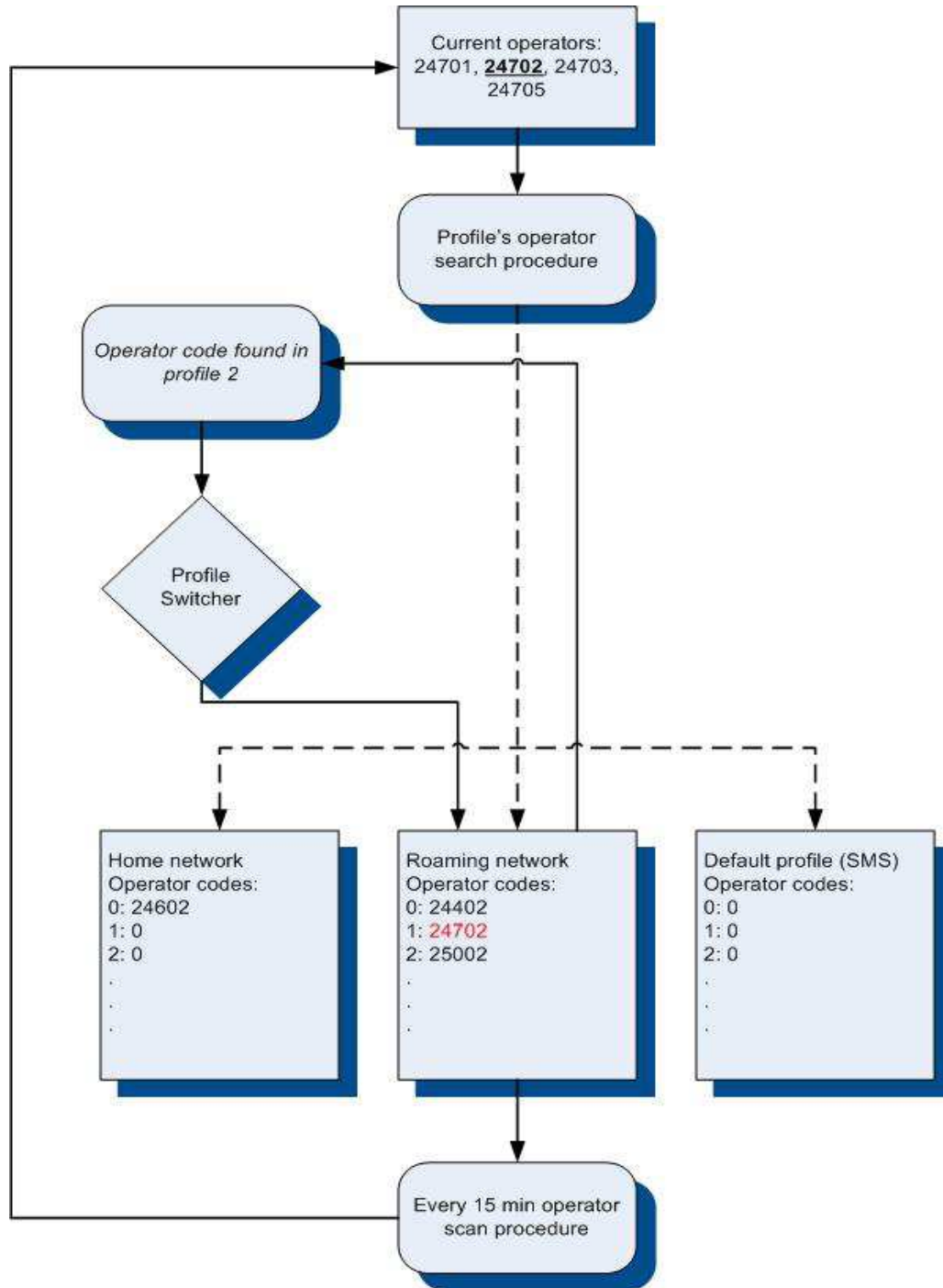

Figure 43 GSM Operator code profile switching (...)

7.2 Profile switching dependence on I/O event

Another profile switch method is based on I/O event. Events happen when the value of enabled I/O intersects thresholds (enter, exit, on both, hysteresis) predefined by High and Low level thresholds. SW21, SW22, SW23, SW24 stands for "Switch to profile No. X". After an event happens, FM6320 switches to a defined profile. Using profile switching you can create smart applications. SW2X actions can be performed only if "Profile change on event" is enabled in Global parameters. Pictures below illustrate profile switching depending on digital events:

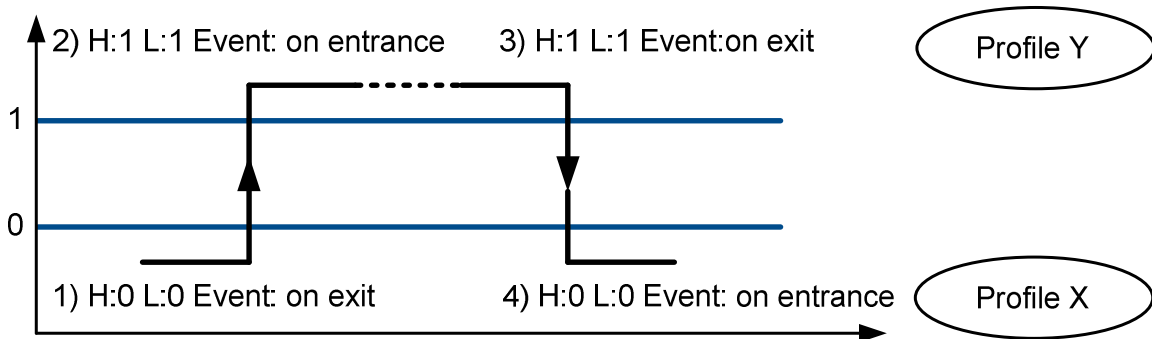

Figure 44 Digital input event criteria

7.2.1 Example #1

Configuration of Profile1 to switch to Profile2 on DIN1 value change from 0 to 1:

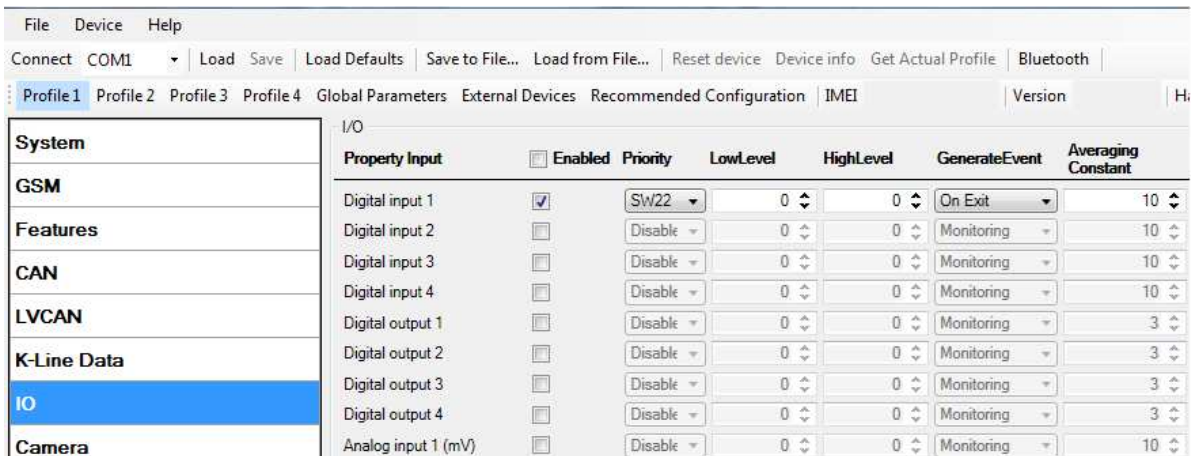

Figure 45 Switch to profile on event (1)

7.2.2 Example #2

Configuration of Profile2 to switch to Profile1 on DIN1 value change from 1 to 0:

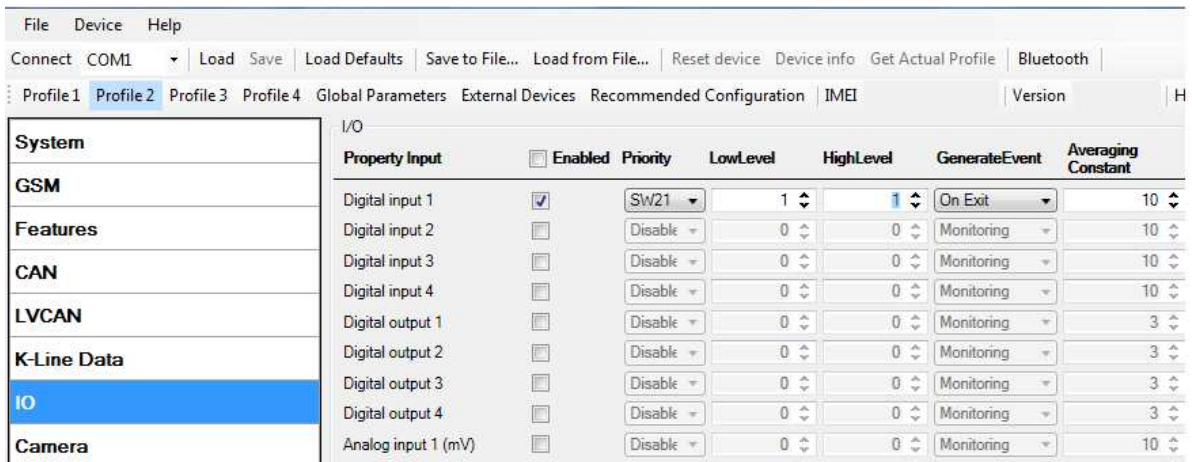

Figure 46 Switch to profile on event (2)

8 DUAL SIM FUNCTIONALITY

FM63 is able to operate in DUAL SIM switching mode to minimize the bill accounts for GSM/GPRS services. To use this mode, 2 SIM Operator list enumerated value must be chosen for Profile Change On setting in Global parameters tab after FM63 is connected to configurator (shown in Figure 47).

When DUAL SIM operating mode is set: profile 1 becomes Home, profile 2 becomes SIM 1 Roaming, profile 3 becomes SIM 2 Roaming and profile 4 becomes Unknown Operator. In this chapter the operation and configuration of DUAL SIM mode is presented.

FM6320 can be used with one SIM. SIM1 card has higher priority than SIM2. For one SIM card using it must be placed in SIM1 slot for FM6320 to switch minimum times.

If SIM card is inserted into SIM 2 slot and 1 SIM operator list mode is used, FM6320 will work normally, but there will be more switching activities. In addition, APN settings in Global parameters should be entered for SIM 1 and SIM 2 to avoid not sending records over GPRS.

When FM6320 connected to configurator choose Global Parameter section as shown on Figure 47, then in Profile Change ON select 2 SIM Operator List.

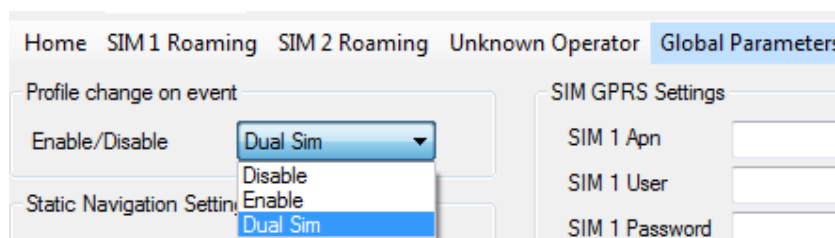

Figure 47 FM6320 Configurator window 2SIM mode setup

You can see four new profiles buttons after changing to 2 SIM Operators list: Home, SIM 1 Roaming, SIM 2 Roaming and Unknown Operator.

SIM 1 and SIM 2 APN settings are set in the Global parameters tab (Figure 48). Some operators use specific authentication for GPRS session – CHAP or PAP. If any of these is used, APN should be entered as 'chap: <APN>' or 'pap: <APN>'. I.e. if operator is using APN 'internet'

with CHAP authentication, it should be entered as 'chap:internet'. Information about APN and authentication type should be provided by your GSM operator.

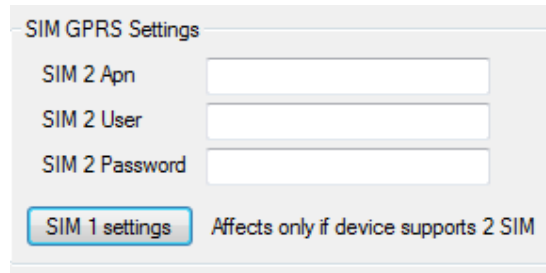

Figure 48 APN settings for SIM 1 and SIM 2

8.1.1 Home Network

Selecting Home profile gives Home Operator Code settings possibility for SIM 1 and for SIM 2 (Figure 49). These Home Operators have the highest priority and must be inserted. FM6320 gets possible operator codes list from the network and compares them with the operator codes inserted in Home profile's list. At first, it tries to connect to SIM 1 Home Operator, if operator is unreachable; the device switches to SIM 2 slot and tries to connect to SIM 2 Home Operator.

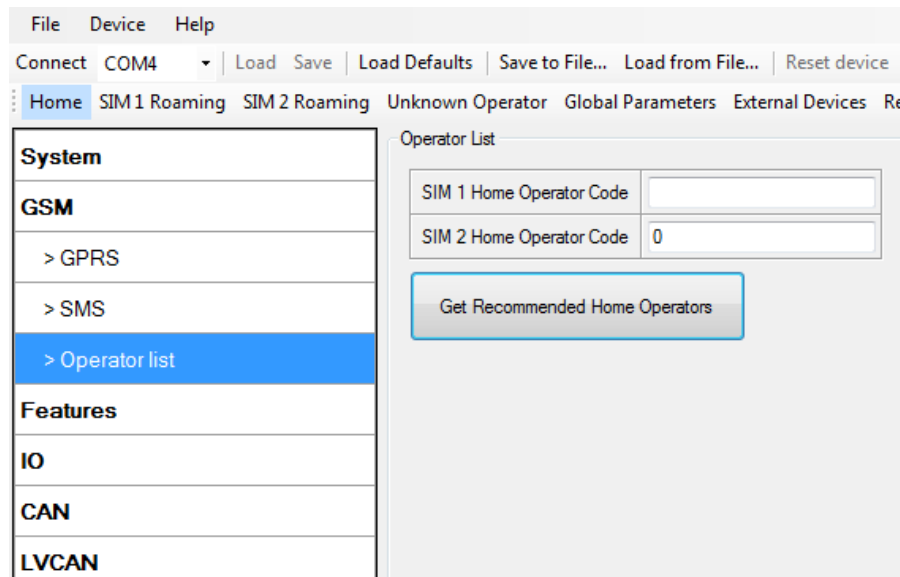

Figure 49 Home network setting

When the connection procedure is successful, FM6320 stays connected to the available Home operator using the SIM card, which was inserted for and works according to the Home profile parameter settings.

If none of the Home operators could be connected with, FM6320 switches to the SIM 1 card tries to connected to its roaming operators from SIM 1 Roaming profile.

8.1.2 SIM 1 Roaming

In this window you can fill the Preferred Operators List for SIM 1, up to 50 operators (Figure 50). SIM 1 Roaming operator list has the second priority after the Home operators. If

there are no available home operators, FM6320 checks if there are available SIM 1 Roaming operators from the list. If there are several available Roaming operators from the list, FM6320 connect to the higher priority operator from the SIM 1 Roaming operator list.

If there are no available operators from SIM 1 Operator list or the list is empty, FM6320 scans the SIM 2 Roaming operator list for available operators.

If the connection is lost, FM6320 will return to Home profile and try to connect to Home operators as it has higher priority. FM6320 checks a possibility to connect to Home network every 10 min. and goes further by priority.

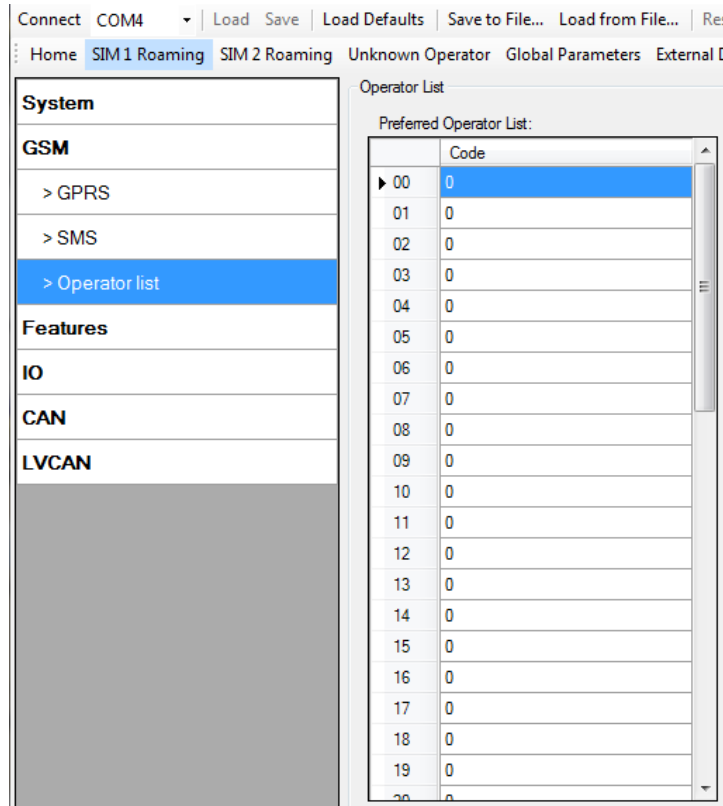

Figure 50 SIM 1 Roaming Operator list

8.1.3 SIM 2 Roaming

In this window you can fill the Preferred Operators List for SIM 2 up to 50 operators (Figure 51). SIM 2 Roaming operators list has the third priority after the Home network and after SIM 1 Roaming operators list. If there are no available operators from Home operator list and SIM 1 Roaming operators list, FM6320 scans for available operator in the SIM 2 Roaming operator list. If there is an available SIM 2 Roaming operator in the list, FM6320 switches the profile to SIM 2 Roaming, switches the SIM card to Slot 2 and connects to available operator from the SIM 2 Roaming operator list.

If the connection is lost, FM6320 will return to scan Home network as it has higher priority, after it goes to scan SIM 1 Roaming operators list as it has the second priority, only will be not connections in higher priorities lists it goes to scan SIM 2 Roaming operators list again. FM6320 every 10 min. checks a possibility to Home network connection and further, if it is necessary, operates by the priority.

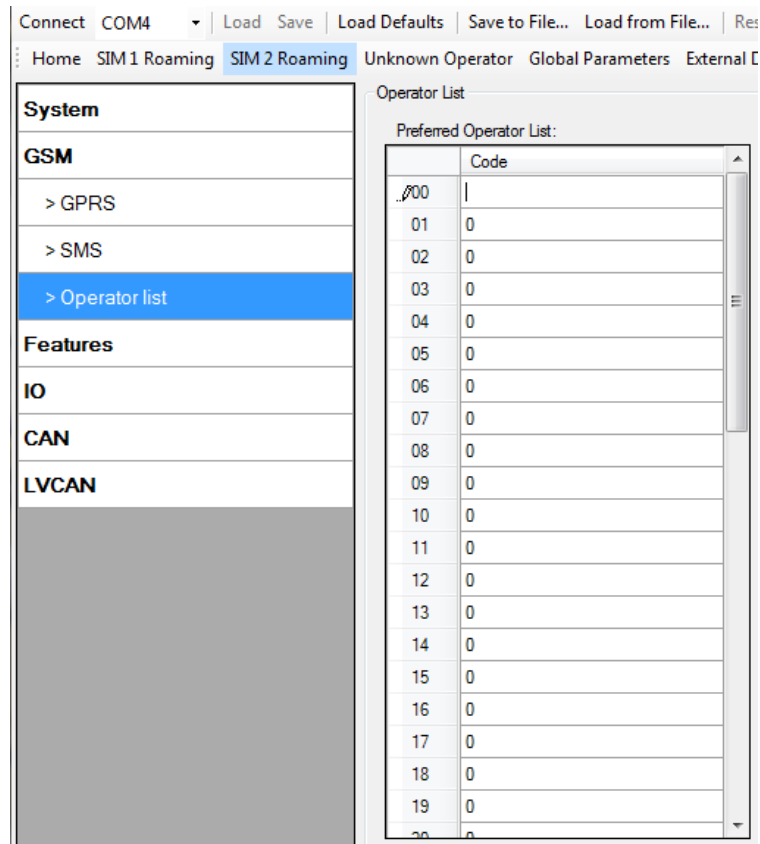

Figure 51 SIM 1 Roaming Operator list

8.1.4 Unknown Operator

Unknown Operator profile (Figure 52) has the fourth priority after the Home network, after SIM 1 Roaming operators list and after SIM 2 Roaming operators list. The user cannot insert operators in Unknown operator list, it is not usable.

The FM6320 switches to Unknown operator profile using the SIM card it has used before (FM6320 doesn't switch the SIM cards) when SIM 1 and SIM 2 operator lists are empty and there is no possibility to connect to SIM 1 and SIM 2 Home operators. In this profile FM6320 connects to an operator from the list, received from the network, with the best signal quality.

FM6320 every 10 min. checks a possibility to Home network connection and further, if it is necessary, operates by the priority.

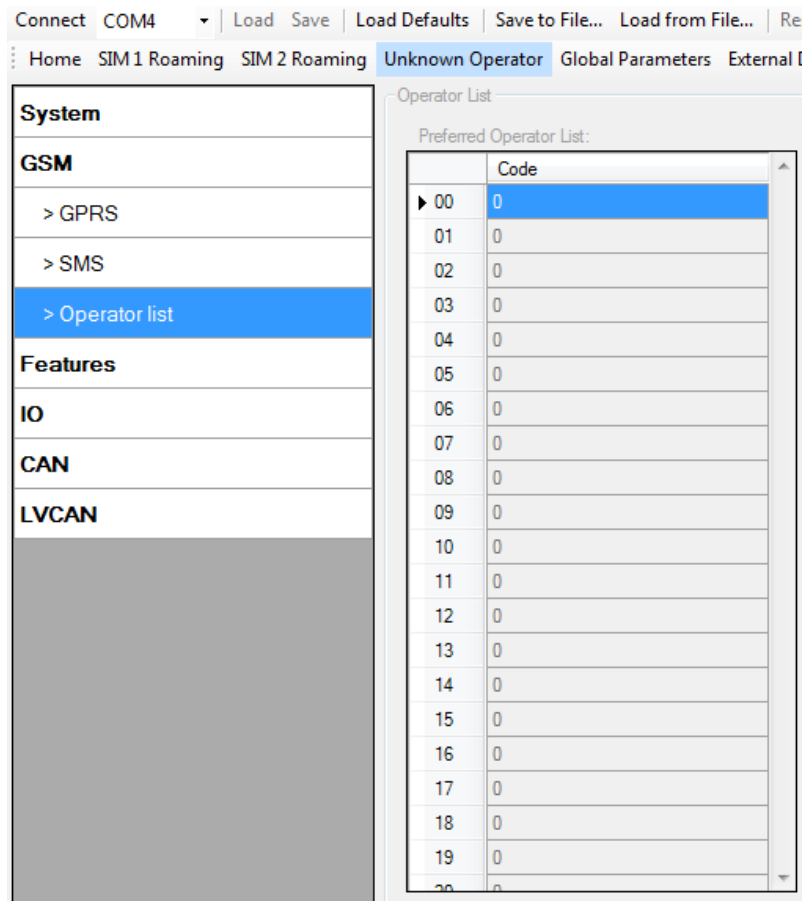

Figure 52 Unknown Operator List

8.1.5 Dual SIM algorithm

Two SIM cards use algorithm is shown in the diagram (Figure 53).

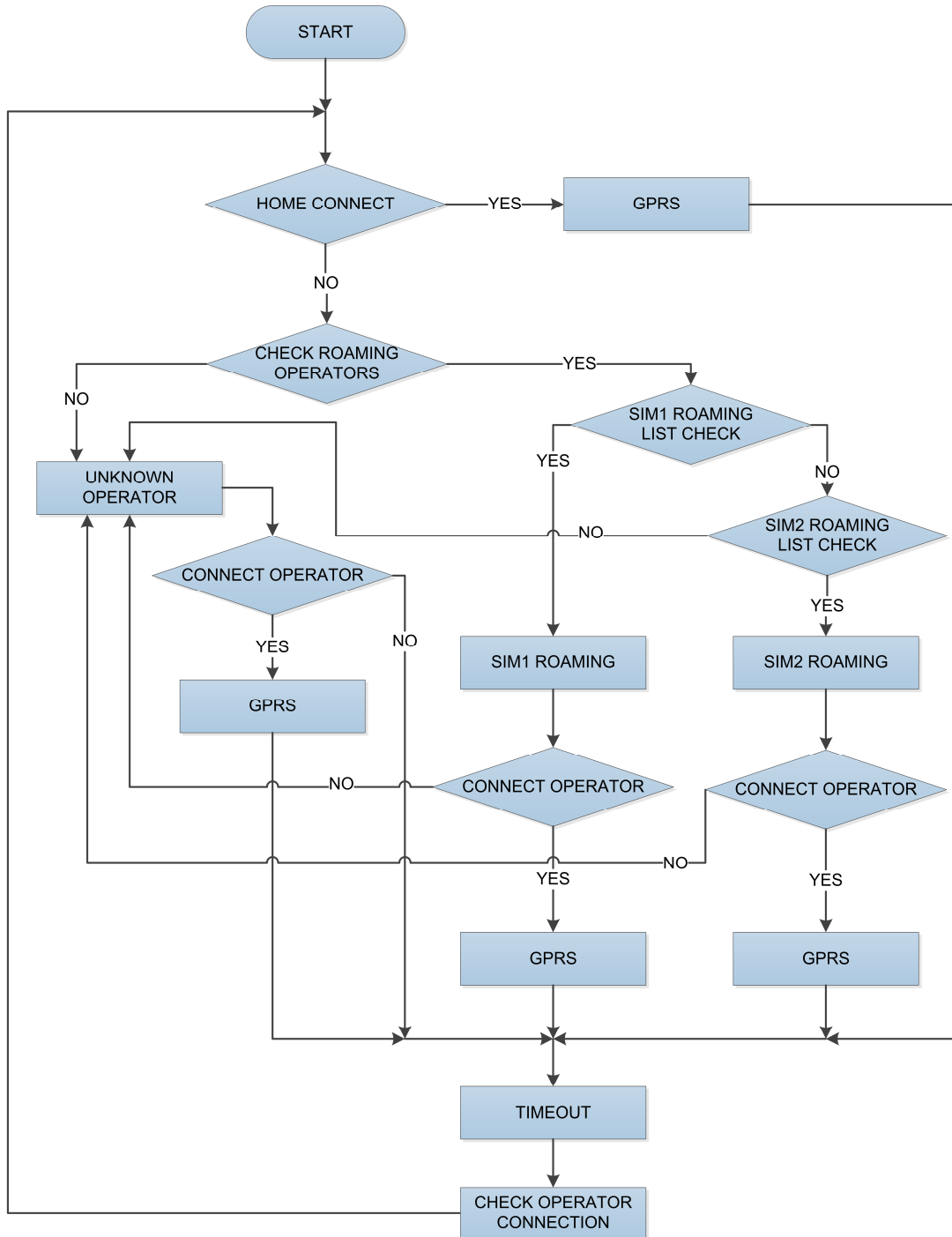

Figure 53 Dual SIM connection algorithm

The FM6320 is always trying to connect to Home operator. If it cannot connect, then it goes to Roaming Operator. The Roaming Operator is chosen by priority. Higher placed operator in the operators list has higher priority. If impossible to connect to Roaming Operator from operator's list or the operators list is empty, then the FM6320 connects to Unknown operator.

In all cases when a timeout has appeared the operator search procedure is done. If better home operator is found or the higher priority operator from the roaming operator list is found, the device connects to it. For example: Home is better than Roaming Operator, Roaming operator is better than Unknown operator. In other cases the primary operator's connection is continued.

9 DATA ACQUISITION

Data can be acquired using GPS or I/O elements. GPS data is for basic vehicle tracking, data acquisition by I/O elements gives more specific information.

9.1 GPS data acquisition

There are four ways of GPS data acquisition which are configured in *Features > sMode* menu (Figure 54).

Device checks angle, distance, and time and speed differences with last saved record. If differences are greater than configured a record is generated. Checking sequence: first angle is checked then distance then time differences and last – speed differences.

Data Acquisition Modes		
Min Period:	300	sec.
Min Distance:	100	m.
Min Angle:	10	deg.
Min Saved Records:	1	
Send Period:	10	sec.
Min Speed:	0	km/h.
Min Speed Source:	GPS Speed	

GPRS Week Time

Figure 54 GPS acquisition configuration window

9.1.1 Min. Period

Time based data acquiring (Figure 55) – records are being acquired every time when defined interval of time passes. Entering zero means that data will not be recorded according to time. This method is suitable best for basic position update.

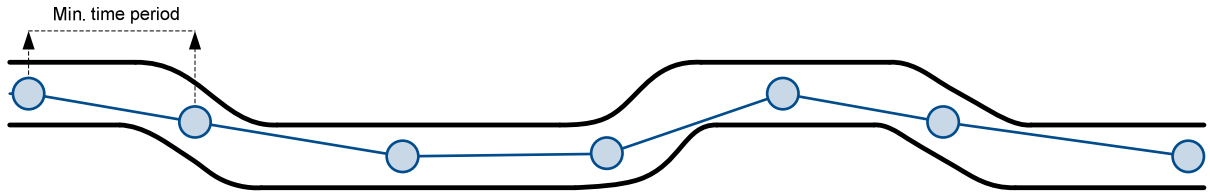

Figure 55 Time based tracking

9.1.2 Min. Distance

Distance based data acquiring (Figure 56) – records are being acquired when the distance between previous coordinate and current position is greater than defined parameter value. Entering zero means that data won't be recorded. This method is suitable for non-urban territories where moving trajectory is straight.

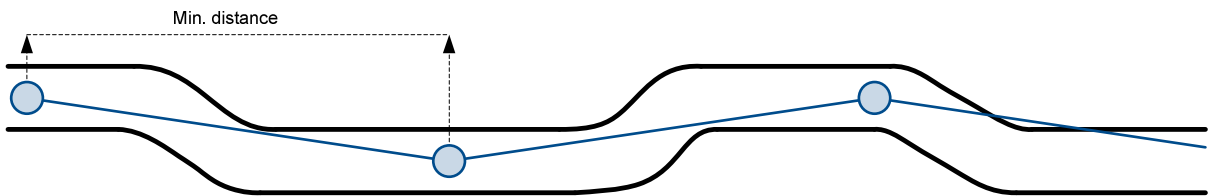

Figure 56 Distance based tracking

9.1.3 Min. Angle

Angle based data acquiring (Figure 57) – records are being acquired when angle difference between last recorded coordinate and current position is greater than the defined value. Entering zero disables data acquisition depending on angle. This method is suitable for urban territories. Note that record generation by angle is performed if vehicle is moving at least 6 km/h.

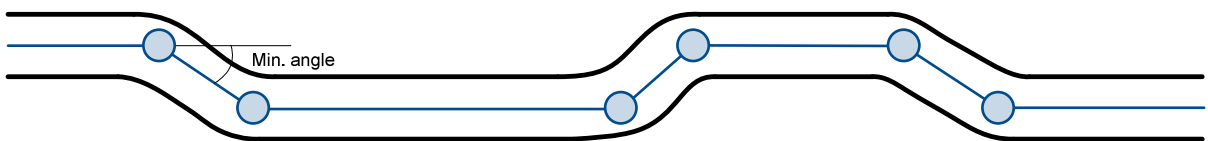

Figure 57 Angle based tracking

9.1.4 Min. Speed

Speed based data acquiring (Figure 58) – records are being acquired when speed difference between last recorded coordinate and current position is greater than the defined value. Entering zero disables data acquisition depending on speed. This method is suitable for urban territories.

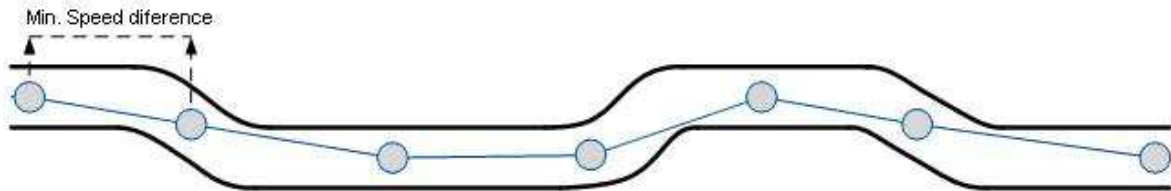

Figure 58 Speed based tracking

9.2 I/O data acquisition

Data also can be acquired using input output elements (it's change). All base elements are Declared in 6.3.8.1 I/O elements list description and in Table 22 EVENTUAL I/O elements list description.

9.2.1 Configuration

Data acquisition by I/O elements can be configured selecting I/O menu in configurator (refer to Chapter 6.3.8.2).

Priority: Low – as a regular data; High – generated record are sent immediately to server; Panic - generated record are sent immediately to server and simultaneously the same record as SMS message;

High Level: High range of value input;

Low Level: Low Range of value input;

Averaging constant: (see detailed description in Chapter 6.3.8.2)

9.2.2 Event generation

There are five record event generation type examples (I/O speed is taken as I/O value example), please refer to Figures below.

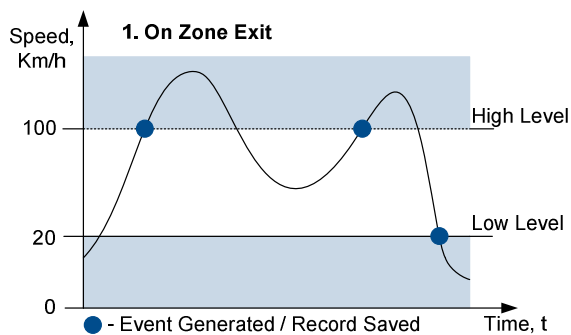

Figure 59 Event On Zone exit

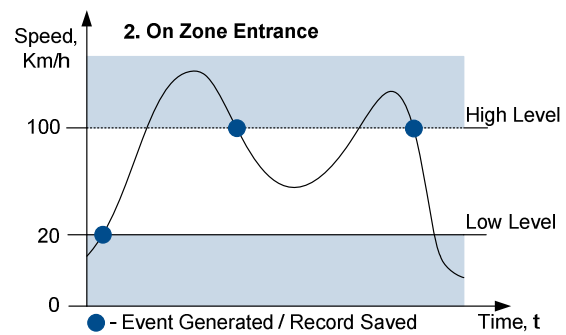

Figure 60 Event On Zone entrance

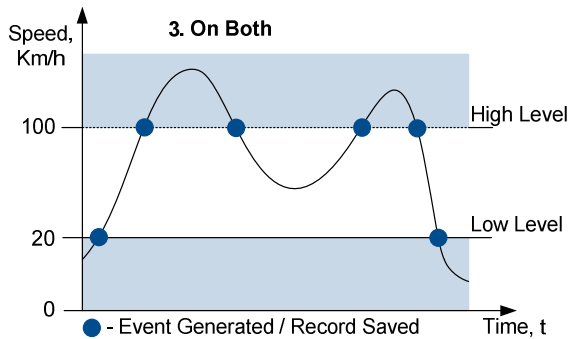

Figure 61 Event On both

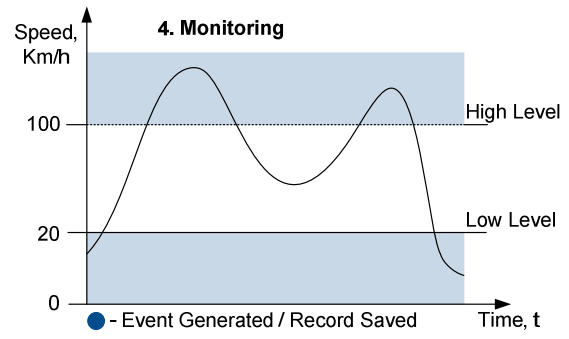

Figure 62 Monitoring

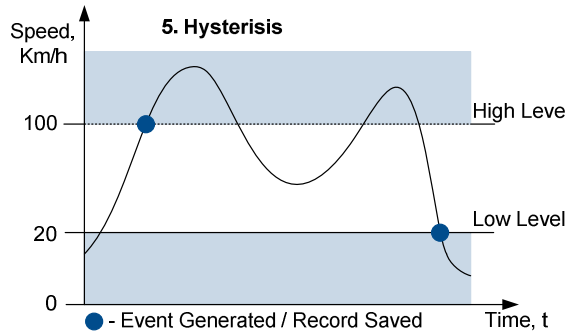

Figure 63 Event on Hysteresis

Event on Zone Entrance: record is generated when actual source value input is between High and Low level ranges which are set in configuration;

Event on Zone Exit: record is generated when actual source value input increases and becomes higher than High level and Low level values;

Event on Both: record is generated when actual source value input increases/decreases and becomes higher/lower than high and low level declared values;

Monitoring: no event at all; I/O values are recorded only when other trigger have worked (GPS acquisition or other I/O trigger)

Hysteresis: record is generated when actual source value input becomes higher than High level value, and decreasing becomes less than Low level value

Event on Change: record is generated on every source value change.

10 SLEEP MODE

While in sleep mode, FM6320 sets GPS receiver to sleep mode but GSM/GPRS module stays active, in Sleep mode power usage can be decreased to save vehicle's battery, because GPS module is turned off.

FM6320 can enter sleep mode if **ALL** of these conditions are met:

- FM6320 has to be configured to work in Sleep mode;
- Start-up timeout has elapsed (5 minutes after every restart of the device);
- No movement by accelerometer is detected;
- Ignition is off;
- USB cable is not connected.

FM6320 exits sleep mode if **ONE** of the following conditions are true:

- Movement by accelerometer is detected (depends on accelerometer start settings);
- Ignition (DIN1) is turned on (driven logic high);
- USB cable is connected;
- HIGH or PANIC priority eventual record is detected;

While being in sleep mode FM6320:

- cannot save periodical or eventual records;
- send data to server;

11 DEEP SLEEP MODE

While in deep sleep mode, FM6320 sets GPS receiver to sleep mode and turns off GSM/GPRS module (it is not possible to wake up device via SMS), therefore records with last good coordinates are being saved and sent to AVL server if configured (GSM/GPRS module is turned on to send data and after turned off). Depending on two configurable parameters, send period and min period, in Deep Sleep mode power usage can be decreased to save vehicle's battery.

FM6320 can enter deep sleep mode (standby mode) if **ALL** of these conditions are met:

- FM6320 has to be configured to work in Deep Sleep mode;
- Start-up timeout has elapsed (5 minutes after every restart of the device);
- No movement by accelerometer is detected;
- Ignition is off;
- Send period is more than 60 seconds (Data Acquisition Mode settings);
- USB cable is not connected.

FM6320 exits deep sleep mode if **ONE** of the following conditions are true:

- Movement by accelerometer is detected (depends on accelerometer start settings);
- Ignition is turned on (driven logic high);
- USB cable is connected;
- HIGH or PANIC priority eventual record is detected;

While being in deep sleep mode FM6320:

- can save periodical or eventual records;
- send data to server;



Note: If there is no need to save or send periodical data FM6320 has to be configured to switch to another profile on Deep Sleep Event where Min Period and Send Period parameters are 0 or big enough.



Note: In order to save GPRS traffic records saved in deep sleep mode contain below listed I/O elements information:

Digital Inputs (1-4), Analog Inputs (1-4), Battery Voltage, Battery Current, Digital Outputs (1-4), External Voltage, Movement Sensor, Deep Sleep.
Also, Deep Sleep I/O is always LOW PRIORITY!

12 FEATURES AND SCENARIOS

Six scenarios are available on FM6320 device. All scenarios can be activated at the same time and all activated scenarios can be configured to control the same DOUT (except excessive idling).

12.1 ECO driving/Green driving Scenarios



ECO driving/Green driving Scenario helps to prevent and inspect driver about harsh driving. Eco driving scenario continuously monitors: accelerating, braking and cornering forces depending on build in accelerometer or Green driving depending on GPS. The device inspects driver if needed. Monitoring sensitivity is configurable.

Any of the four DOUT can be configured and then controlled by scenario for user needs, buzzer or LED for example. Output activation time after harsh event is also configurable.

To save GPRS traffic ECO driving/Green driving event will be **generated (included into records) only** when FM6320 measured values are higher than those set in configuration, without additional I/O settings.

To prevent generating false events for Green driving, harsh acceleration and harsh braking is monitored only when following conditions are fulfilled:

- Ignition is ON
- Vehicle speed is equal or higher than 10km/h

Harsh cornering is monitored only when following conditions are fulfilled:

- Ignition is ON
- Vehicle speed is equal or higher than 30km/h

To prevent generating false events for ECO driving, harsh acceleration and harsh braking is monitored only when following conditions are fulfilled:

- Ignition is ON

Harsh cornering is monitored only when following conditions are fulfilled:

- Ignition is ON

ECO driving or Green driving Scenario: Eco driving is based on accelerometer value and Green driving based on GPS position.



PLEASE NOTE that Eco Driving functionality is dependent on accelerometer. Device must be mounted correctly on plain/horizontal surface. FM63 measures relative acceleration every second.

12.1.1 Mounting Requirements



PLEASE PAY ATTENTION, that ECO driving functionality will operate correctly only if device is mounted into the vehicle in a proper position.

ECO driving functionality operation is based on accelerometer. It is important to mount FM6320 device correctly to avoid functionality malfunctions (first condition). In the picture below (Figure 64) mounting recommendations are displayed. Please **note** that beside those recommendations

1. You can choose how FM6320 is deployed. It means that that there is no effect to measurements if FM6320 top/bottom side points up or down.
2. Device can be deployed at any place in the car.

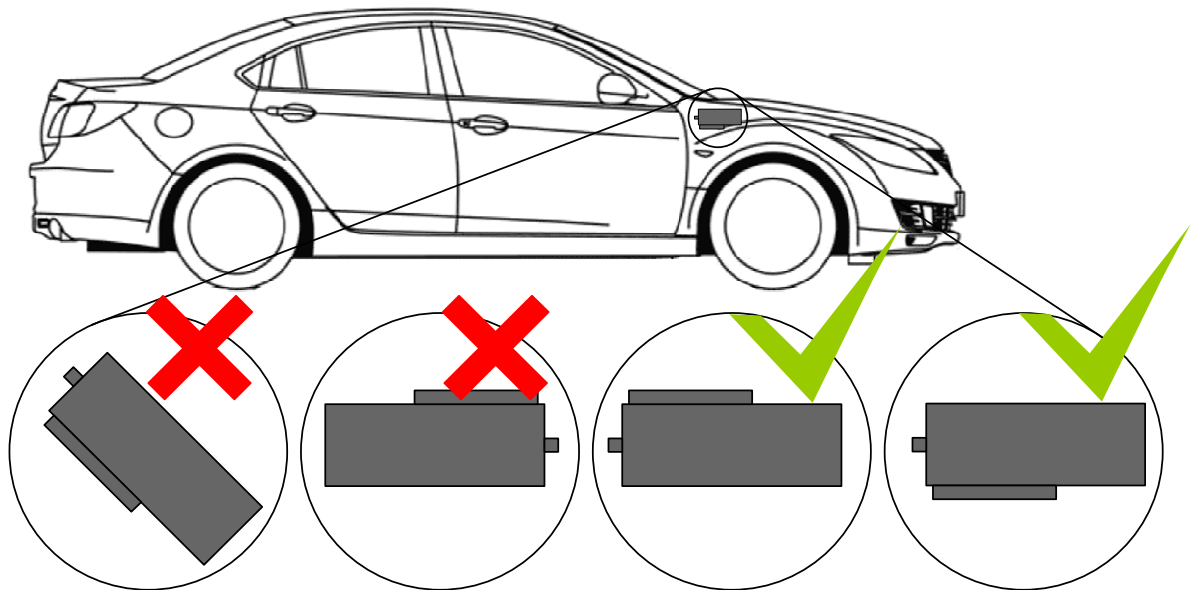

Figure 64 Correct mounting position of the FM6320 in the vehicle

For ECO driving to work properly, device connection pins socket must point towards the vehicles front side. Deviations of $\pm 2^\circ$ are allowed. But it should be as straight as possible.

Deviations of maximum $\pm 15^\circ$ are allowed (Figure 65).

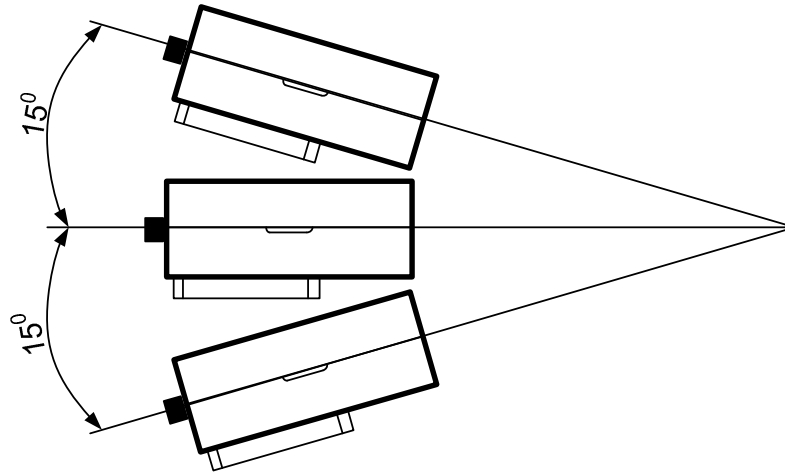

Figure 65 MAX deviation from horizontal plane of FM6320 mounting

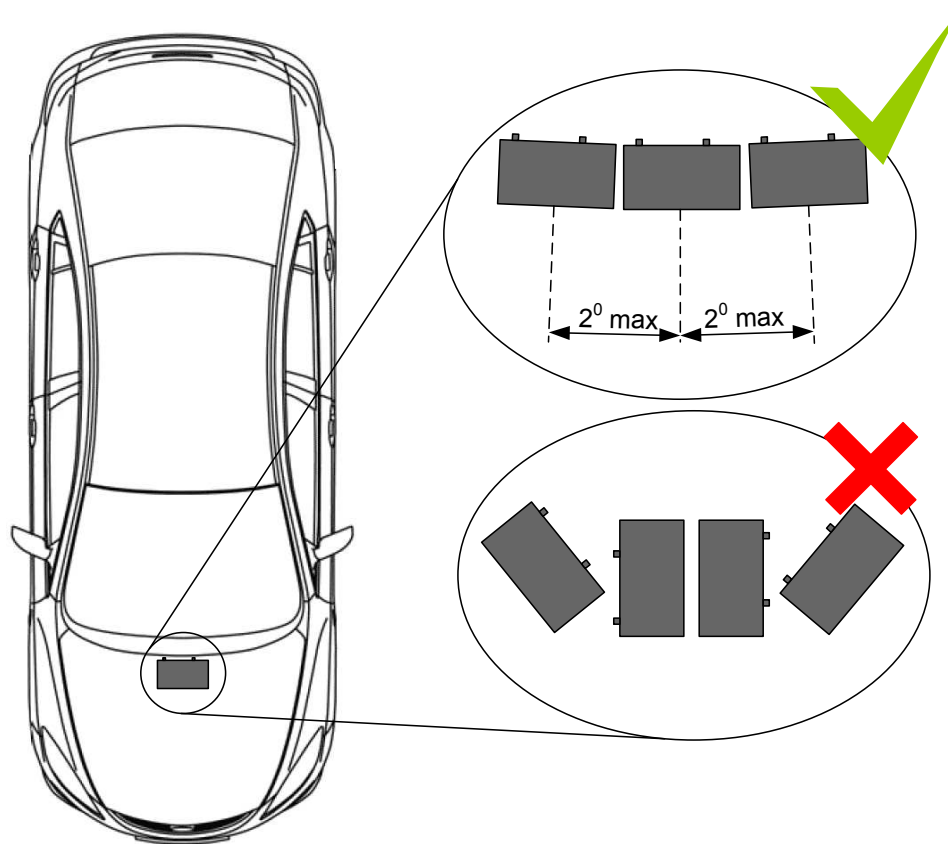

Figure 66 Horizontal position MAX deviation of FM6320 mounting

Horizontal position must be as flat as possible – parallel with vehicle plain.

12.1.2 Configuration

Parameters used with ECO driving/Green driving functionality.

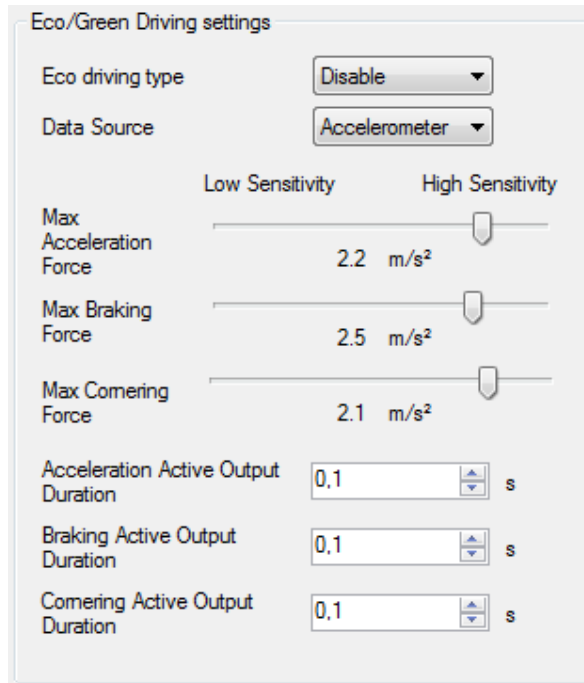

Figure 67 ECO driving/Green driving configuration parameters

Table 33 ECO driving/Green driving parameters description

ECO driving/Green driving configuration parameter name	Description
ECO driving type	Selects which DOUT will control scenario
Data source	Selects from where data will be taken
Max Acceleration Force	Value which can be reached while accelerating without triggering harsh acceleration event.
Max Braking Force	Value which can be reached while braking without triggering harsh braking event.
Max Cornering Force	Value which can be reached while cornering without triggering harsh cornering event.
Acceleration Active Output Duration	Set active output duration after harsh acceleration event detected
Braking Active Output Duration	Set active output duration after harsh braking event detected
Cornering Active Output Duration	Set active output duration after harsh cornering event detected

12.1.3 Data output

ECO driving/Green driving functionality generates events on three cases. If vehicles:

- Acceleration exceeds defined parameter value

- Deceleration (braking) exceeds defined value
- Cornering force exceeds defined value

Program continuously monitors and process data from accelerometer than decides whether harsh event is detected or not. If any of three cases are satisfied event is generated. Record is saved and sent to server (FM6320 must be configured properly). Event value is multiplied by 10 before sending/saving record to get more precision when displaying **data***.

Digital output No.1 is activated for a period of time to warn driver. Output on-time should/can be configured separately for each case.

***Example.** If acceleration harsh event of 3.55 m/s² detected. Record with value $3.55 * 10 = 35.5 \approx 36$ will be saved and sent to server.

12.2 Overspeeding Scenario

Overspeeding. Helps to prevent from exceeding fixed speed and inspects driver if needed. Any DOUT (which is configured) is controlled by scenario for user needs, to manage buzzer, LED etc.

12.2.1 Mounting Requirements and Working Conditions

1. All scenarios on corresponding Digital Output can be enabled at once.
2. Ignition must be on.
3. Device module mounting position doesn't have any influence for correct scenario operation.

12.2.2 Configuration

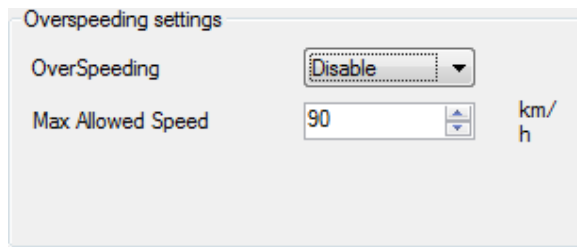

Figure 68 Overspeeding configuration parameters

Overspeeding. Selects which DOUT will control Overspeeding scenario.

Max Allowed Speed. Set speed limit to reach without triggering Overspeeding event.

12.3 Immobilizer/ Authorized Driving Scenario

Immobilizer (iButton list checking disabled) Vehicle can be used only if iButton is connected. In this scenario iButton list is not used; connect any iButton to pass Immobilizer security. Selected DOUT is controlled by scenario for user needs.

12.3.1 Configuration

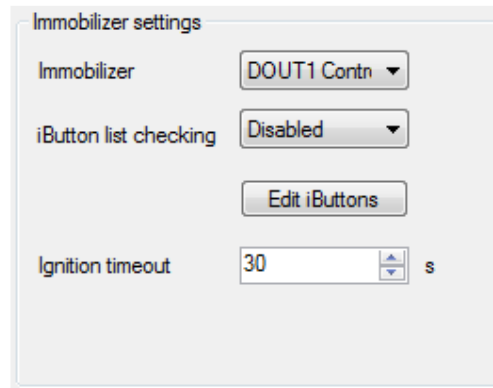

Figure 69 Immobilizer configuration parameters

Immobilizer. Selects which DOUT will control Immobilizer Scenario.

iButton list checking. When Disabled turn on Immobilizer Scenario.

Ignition timeout. Time that need to be passed when ignition (DIN1) turns off to reactivate scenario.

Authorized Driving (iButton list checking enabled). Gives ability to use vehicle for 500 specific iButton owners (specified in iButton list). Selected DOUT is controlled by scenario for user needs, to manage buzzer, LED etc.

12.3.2 Configuration

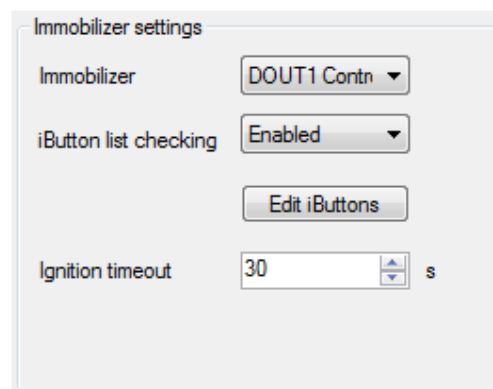

Figure 70 Authorized driving configuration parameters

Immobilizer. Selects which DOUT will control Immobilizer Scenario.

iButton list checking. When Enabled turn on authorized driving Scenario.

Ignition timeout. Time that need to be passed when ignition (DIN1) turns off to reactivate scenario.

12.4 Excessive Idling Scenario

Scenario is activated when vehicle stops for specific amount of time. You can configure time it takes to turn on this scenario (Time to Stationary). Scenario is activated until vehicle starts moving and keeps moving for amount of time that is configured (time to movement).

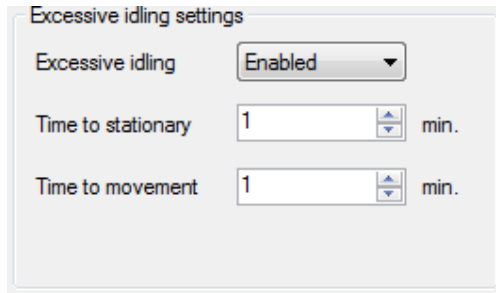

The image shows a configuration window titled "Excessive idling settings". It contains three settings:

- Excessive idling:** A dropdown menu set to "Enabled".
- Time to stationary:** A numeric input field set to "1" with "min." to its right.
- Time to movement:** A numeric input field set to "1" with "min." to its right.

Figure 71 Excessive Idling Configuration

12.5 Jamming Detection Scenario

Scenario is activated and DOUT can be control when jamming is detected

12.5.1 Configuration

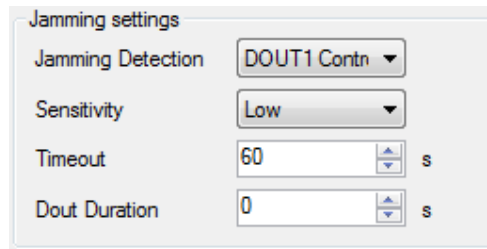

The image shows a configuration window titled "Jamming settings". It contains four settings:

- Jamming Detection:** A dropdown menu set to "DOUT1 Contr".
- Sensitivity:** A dropdown menu set to "Low".
- Timeout:** A numeric input field set to "60" with "s" to its right.
- Dout Duration:** A numeric input field set to "0" with "s" to its right.

Figure 72 Jamming Detection Configuration

Jamming Detection: Scenario Enable, Disable and DOUT selection

Sensitivity: Sensitivity to control false jamming detection

Timeout: Jamming timeout is the duration after how much time device should initiate jamming event after detecting jamming.

Dout Duration: Time, how long DOUT should stay active after jamming detection event is generated.

12.6 iButton Notification Scenario

Gives ability to use ibutton to control DOUT for configurable amount of time. When iButton is attached and is successfully read, configured DOUT goes ON

12.6.1 Configuraton

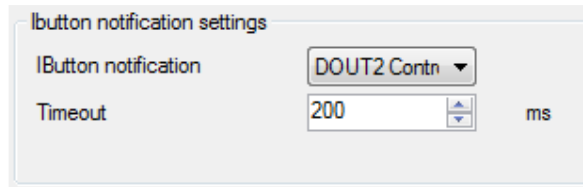

Figure 73 iButton notification configuration parameters

iButton notification: Selects which DOUT will control this scenario

Timeout: Configurable amount of time for which DOUT will be ON

12.7 Crash Detection Scenario

Scenario is activated when Crash is detected by device using accelartaion values

12.7.1 Configuration

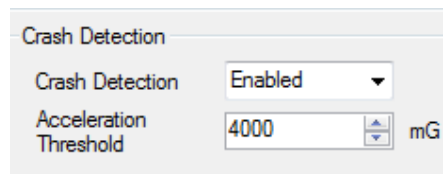

Figure 74 Crash detection configuration parameters

Crash detecion: : Scenario Enable or Disable

Acceleration threshold: Acceleration values, Scenario is activated if configured value exceeds

12.8 COM1 and COM2 Working Modes

12.8.1 Silent Mode

FM6320 doesn't do any activity in silent mode. Logs aren't saved and any data isn't sent.

12.8.2 FM Log Mode

This is default mode of the FM6320. It is suitable for debugging.

12.8.3 LLS Mode

12.8.3.1 LLS Mode Configuration

1. Globals->COM2 Settings->Baudrate = 19200
2. Globals->COM2 Settings->Mode = LLS

Note

COM2: Level will be with ID:203 Temperature will be with ID:204.

On Valid data Receive Status LED will blink.

12.8.4 LCD Mode Configuration

1. External Devices->COM2 Settings->Baudrate = 57600
2. External Devices ->COM2 Settings->Mode = LCD

How to use:

- * From Terminal need send command "WT^W your text here"
- * From Hercules (server) Send "#DO DAT=you text here" (in special packet)

Notes:

#DO DAT= command prints only to COM2

Link between FM and server has to be established for this functionality to work

On Valid data Receive Status LED will blink.

12.8.5 RFID HID Mode Configuration

1. External Devices ->COM2 Settings->Baudrate = 57600
2. External Devices ->COM2 Settings->Mode = RFID
3. External Devices ->COM2 Settings->Parity = Even

12.8.6 RFID MF7 Mode Configuration

1. External Devices ->COM2 Settings->Baudrate = 9600
2. External Devices ->COM2 Settings->Mode = RFID MF7
3. External Devices ->COM2 Settings->Parity = None

12.8.7 Garmin Mode Configuration

12.8.7.1 Settings

1. External Devices ->COM2 Settings->Baudrate = 9600
2. External Devices ->COM2 Settings->Mode = Garmin
3. External Devices ->COM2 Settings->Parity = None

Ping Filter Enable Parameter:

0 - [DISABLED] = Ping packet will not be blocked.

1 - [ENABLED] = Ping packet will be blocked.

Unicode Support Packet Enable Parameter:

0 - [DISABLED] = Unicode Packet will be send to server.

1 - [ENABLED] = Unicode Support Packet will not be send to server.

12.8.7.2 Firmware Configuration

Supported Garmin protocols: A***

(<http://developer.garmin.com/lbs/fleet-management/fmi-protocol-support-matrix/>)

Blocked Garmin ID's:

- Command 0A
- Date/Time Data 0E
- Unit ID/ESN 26
- Pvt Data 33
- Legacy Stop Message 87
- Legacy Text Message 88
- Ping 0260
- Ping response 0261
- Product ID Request 0001
- Product ID Data 0002

FM send ACK the these packets, ant these packets are not sent to server to reduce traffic.

Allowed Garmin ID's:

- ACK 06
- NAK 15
- Fleet Management Packet A1

Note:If packet are not listed here packet ID will be ignored.

12.8.8 TCP Link Mode

In this mode link with external device using text messages can be established.

Any string of data coming to COM will be routed to server. (if link is currently active) First message will be packet to special packet⁸. Packet will be sent as Codec12.

If you want to send message to COM, you need to pack in special packet.

1. External Devices ->COMx Settings->Baudrate = any of available baudrates
2. External Devices ->COMx Settings->Mode = TCP Link Mode
3. External Devices ->COMx Settings->Parity = any setting
4. When sending a packet through COMx don't forget to enter a new line otherwise the packet will not be recognized. Packet format: <enter your message> <enter new line> - send. For example: *message/n* or in HEX it should look like: *6D 65 73 73 61 67 65 0D 0A*

These parameters are automatically configured when TCP Link mode is selected:

- * Record refresh timeout 9999999 sec.
- * ignores weektime, timesync, and records

12.8.9 TCP Link Mode (Binary)

This mode is the same as above but binary message doesn't need new line. Packet will be sent as Codec12. Packet format: <enter your message> - send. For example: *message* or in HEX it should look like: *6D 65 73 73 61 67 65*

⁸ For additional information of special packet, please contact to your local sales representative

1. External Devices ->COMx Settings->Baudrate = any of the available baudrates
2. External Devices ->COMx Settings->Mode = TCP Link Mode(Binary)

FM63 supports buffering messages when there is no data link, messages will be saved to flash with a timestamp. Space reserved for buffering is 64 kB. By default buffering is disabled. To enable set "TimeStamp" property. Buffered messages will be sent using Codec13 protocol.

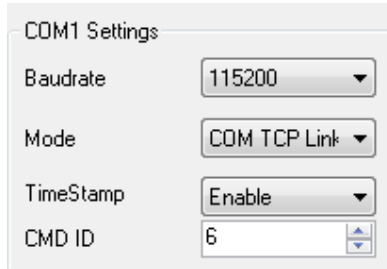

Figure 75

Note. There is a default timeout which is 30ms. When no packets are received for more than 30ms, its seen as the end of the packet.

12.8.10 NMEA Log Mode

In this mode NMEA logs are sent via COM2 ports.

12.8.11 Records to LCD mode

In this mode records are sent via ports.

13 SMS COMMAND LIST

SMS commands are used to identify FM6320 current state, possible configuration errors, perform reset, set parameters, switch on/off outputs, etc.

SMS commands should be sent along with module login and password and sender number must be entered in the authorized number list (if at least one other number is entered). Please see SMS settings in Chapter 6.3.5.3 for more details.

SMS structure is as follows:

<login><space><password><space><command>

Example:

opa opa getgps

Table 34 SMS command list and description

Command	Description	Response
getstatus	Modem Status information	Yes

Command	Description	Response
getweektime	Current device time, Day of Week and amount of minutes passed since start of week	Yes
getops	List of currently used and available GSM operators	Yes
readops#	Emergency gsm operator readout from active profile # - 1,2,3 1 – operators [1-20] 2 – operators [21-40] 3 – operators [41-50]	Yes
getnmeainfo	Nmea error debug sms	Yes
getcfgtime	Date and Time of last successful configuration	Yes
getgps	Current GPS data and time	Yes
loadprofile#	Load specified profile into RAM Engine Profile. # - number of profile to load	Yes
cpureset	Reset CPU	No
resetallprof	Reset all FLASH profiles to default profile	Yes
getver	Device / Modem / Code version information	Yes
getinfo	Device runtime system information	Yes
deleterecords	Delete all records saved on FLASH	No
getio	Readout digital inputs and outputs, analog inputs	Yes
radio #	Readout input value according entered ID, # - ID value	Yes
setdigout XXXX Y1 Y2 Y3 Y4	Set digital outputs 0 – OFF, 1 – ON Y1 – timeout for DO1 Y2 – timeout for DO2 Y3 – timeout for DO3 Y4 – timeout for DO4	Yes
getparam #	Readout parameter value according entered ID. # - ID value.	Yes
setparam # #	Set parameter value according entered ID and Value. 1.# - ID value. 2.# - New Parameter Value	Yes
flush #,#,#,#,#,#,#	Initiates all data sending to specified target server 1.# - IMEI 2.# - APN 3.# - LOGIN 4.# - PASS 5.# - IP 6.# - PORT 7.# - MODE (0-TCP/1-UDP)	Yes
sn x [x=0;1]	Enable/disable static navigation	Yes
banlist	Banlist information	Yes
crashlog	Crash log information	Yes
delete_all_sms	Delete all read SMS	No
getgns	Current GNSS information	Yes
odinfo	Current odometer information	Yes
prof2backup	Saves configuration to backup	Yes

Command	Description	Response
backup2prof	Recovers saved profile	Yes
backupinfo	Backup information	Yes

13.1 getstatus

Table 35 getstaus command response

Response details	Description
Data Link	Indicate module connection to server at the moment: 0 – Not connected, 1 – connected
GPRS	Indicate if GPRS is available at the moment
Phone	Voice Call status: 0 – ready, 1 – unavailable, 2 – unknown, 3 – ringing, 4 – call in progress, 5 – asleep
SIM	SIM Status: 0-ready, 1-pin, 2-puk, 3-pin2, 4-puk2
OP	Connected to GSM Operator: Numerical id of operator
Signal	GSM Signal Quality [0-5]
NewSMS	Indicate if new message received
Roaming	0 – Home Network, 1 – roaming
SMSFull	SMS storage is full? 0 – ok, 1 – SMS storage full
LAC	Location Area Code
Cell ID	Cell ID
Network Type	Information about connected network: 0 – 3G, 1- 2G

Answer Example: Data Link: 0 GPRS: 1 Phone: 0 SIM: 0 OP: 24602 Signal: 5 NewSMS: 0 Roaming: 0 SMSFull: 0 LAC: 0 Cell ID: 0 Network Type:0

13.2 getweektime

Table 36 getweektime command response

Response details	Description
Clock Sync	Indicates system clock synchronization status. 0 – System is not synchronized, 1 – System synchronized
DOW	Day Of Week – indicates current day of week starting from 1 – Monday, 2 – Tuesday, etc.
Time	Indicates current GMT time
WeekTime	Indicates time in minutes starting from Monday 00:00 GMT

Answer Example: Clock Sync: 1 DOW: 4 Time 12:58 Weektime: 6538

13.3 getops

Table 37 getops command response

Response details	Description
------------------	-------------

LIST	Returns list of current available allowed operators.
------	------------------------------------------------------

Answer Example: GSM OP LIST: 0. 24602

13.4 readops

Table 38 readops command response

Response details	Description
LIST	Returns acknowledgment of operators in active profile configuration.

13.5 getnmeainfo

Table 39 getnmeainfo command response

Response details	Description
BChSum	Nmea packets with bad checksum counter.
HAct	Actual HDOP
BT	Nmea packets with bad timestamp counter
BLat	Nmea packets with bad latitude counter
BLon	Nmea packets with bad longitude counter
BSpd	Nmea packets with bad speed counter
BAng	Nmea packets with bad angle counter
GJC	Nmea packets with GPS jumps counter
Rjc	Rejected Nmea packets counter

13.6 getcfgtime

Table 40 getcfgtime command response

Response details	Description
Date/Time	Returns last performed configuration date and time.

Answer Example: Last Configuration was performed on: 2010.4.15 5:45:19

13.7 getgps

Table 41 getgps command response

Response details	Description
GPS	Indicates valid (1) or invalid (0) GPS data
Sat	Count of currently available satellites
Lat	Latitude (Last good Latitude)
Long	Longitude (Last good Longitude)
Alt	Altitude, m
Speed	Ground speed, km/h
Dir	Ground direction, degrees
Date	Current date
Time	Current GMT time

Answer Example: GPS:1 Sat:7 Lat:54.71473 Long:25.30304 Alt:147 Speed:0 Dir:77 Date: 2007/8/24 Time: 13:4:36

13.8 loadprofile#

Returns acknowledgment of successful profile changing from currently used to preferred.
Example: Profile Nr.1 successfully changed to Profile Nr.3

13.9 cpureset

Resets cpu – does not send a response back to the sender.

13.10 resetallprof

Resets all FLASH profiles to default profile.
Answer Example: All Profiles Reseted.

13.11 getver

Table 42 getver command response

Response details	Description
Code Ver	Firmware version
Device IMEI	IMEI
Device ID	Device ID is used to detect which type of configuration to load
BL Ver	Bootloader Version
Modem App Ver	Version of modem application
Hw	Hardware type

Answer Example: Code Ver:01.02.12 Rev:1 Device IMEI:353976010139156 Device ID:000007 BL Ver:05.16 Modem Ver:TM11Q_R_01.03.04.00_004 Hw:Int Bat + GGG + LIS3DH

13.12 getio

Table 43 getio command response

Response details	Description
DI#	Digital Input state
DO#	Digital Output state
AI#	Analog Input state

Answer Example: DI1:0 DI2:0 DI3:0 DI4:0 AI1:0 AI2:0 DO1:0 DO2:0 DO3:0 DO4:0

13.13 getinfo

Table 44 getinfo command response

Response details	Description
INI	Device Initialization Time
RTC	RTC Time
RST	Restart Counter
ERR	Error Counter
SR	Number of Sent Records
BR	Number of broken records

CF	Profile CRC Fail counter
FG	Failed GPRS counter
FL	Failed link counter
UT	UPD Timeout counter
P#	Current profile
##;##;##;#	# - how many times appropriate profile (Profile0; Profile1; Profile2; Profile3; Profile4) was loaded
SMS	Sent SMS Counter
NOGPS	No GPS Timer
GPS	GPS receiver state. 0 – OFF, 1 – restarting, 2 – ON but no fix, 3 – ON and operational, 4 – sleep mode
SAT	Average satellites
RS	Reset Source Identification
RF	Number of records found on FLASH

Answer Example: INI:2007/8/24 10:15 RTC:2007/8/24 12:43 RST:2 ERR:11 SR:182 BR:0 CF:0 FG:0 FL:0 UT: P:1;0;1;0;0;0 SMS:2 NOGPS:0:0 GPS:3 SAT:7 RS:7 RF:11

13.14 deleterecords

Deletes all saved records from device memory. Device does not send a response back to the sender.

13.15 readio

Table 45 readio command response

Response details	Description
ID	IO element ID
Value	IO Element value

Answer Example: IO ID:3 Value:0

13.16 setdigout ##### X Y Z W

Sets digital outputs to ON or OFF state (for some time if needed). Value is written as a row for OUT1, OUT2, OUT3, OUT4 values.

Example: 'setdigout 0010 0 0 5 0' will set OUT3 to high level for 5 seconds, while OUT1, OUT3 and OUT4 to low level.

Ans. example: "DOUTS are set to:0010 TMOs are: 0 0 5 0. Out1 Scenario: Enabled Out2 Scenario: Disabled"

13.17 getparam

Read parameter value. ID consists of 4 digits – first digit identifies profile, second, third and fourth identifies parameter ID as described in Parameters Configuration chapter 6.3.

Table 46 getparam#####

Response details	Description
ID	Profile number and parameter ID

Value	Parameter value
-------	-----------------

Example: 'getparam 1245' command will request server IP address in profile1.

13.18 setparam ##### #

Sets new value for parameter. ID consists of 4 digits – first digit identifies profile, second, third and fourth identifies parameter ID as described in Parameters Configuration chapter 6.3. In value field a new parameter value is entered.

Example: 'setparam 1245 127.0.0.1' will change configured IP address in profile1 with new value

13.19 flush #,#,#,#,#,#

Initiates all data sending by GPRS to specified target server. Comma separated parameters go as numbered:

- 1.# - IMEI
- 2.# - APN
- 3.# - GPRS LOGIN
- 4.# - GPRS PASSWORD
- 5.# - IP
- 6.# - PORT
- 7.# - MODE (0-TCP/1-UDP)

Parameters are separated by comma (no spaces needed). In case you do not need to enter parameter (Login/Pass) – do not put space, simply put comma and write next parameter.

Example: opa opa flush 353976012555151,banga,,212.47.99.62,12050,0

Table 47 flush

Response details	Description
FLUSH SMS Accepted	FLUSH SMS Accepted
# records found on FLASH	Number of records found on FLASH
Minimum Records to Send: #	Number of minimum saved records to send
GPRS Enabled: #	State of the GPRS connection, 0 – disabled; 1 – enabled
Time Sync: #	Indicates time synchronization on the device, 0 – not synchronized; 1 – synchronized

Answer Example: FLUSH SMS Accepted. 11 records found on FLASH. Minimum Records to Send: 1. GPRS Enabled: 1. Time Sync: 1.

13.20 getgnss

Table 48 getgnss

Response details	Description
FIX	GPS fix
SAT GL	Total glonass sattelites
GP	Total gps sattelites

Answer Example: FIX:1 SAT GL:5 GP:10

13.21 sn x

Returns state of static navigation and previous state: Static Nav is Disabled. Was:X or Static Nav is Enabled. Was:X (1 – enabled, 0 – disabled). If sent X is not 0 or 1, then response is: WARNING: Undefined SN parameter: X.

13.22 banlist

Returns a list of possible banned operators. If device returns zeroes, there are no banned operators saved. Format: A.Bs.C.D

Table 49 banlist

Response details	Description
A	Banned operator code
Bs	Time left
C	Reason (1 – can't connect to operator; 2 – can't open GPRS connection; 3 – operator closed connection itself; 4 – connection to operator was successful, but after that device was disconnected from GSM network)
D	Counter (how many times this operator code was already banned)

13.23 crashlog

Returns list of possible device crashes.

13.24 braminfo

Table 50 braminfo

Response details	Description
Boot	Bootloader parameter
Uptime	Device uptime
RST	Device reset counter
IWDF_RST	Independent watchdog reset counter
BadRec	Bad record counter
AD	Authorized driving state
GD	ECO driving/Green driving state
IM	Immobilizer state

13.25 odinfo

Odometer Debug

Table 51 odinfo

Field Name	Full Name	Possible values
E	Odoemter Enable	0-Disable 1-Enabled
V	Odometer Value	0-UINT32_MAX
M:	Mode	0- Differential 1- Continuous
Mv:	Movement	0- Not moving 1- moving
GPS:	GPS Module Status	0-OFF 1-Restarting 2-Ready no FIX 3-Working FIX 4-Sleep
FIX:	GPS FIX	0- No FIX 1- FIX
Valid:	Valid Nmea data	0- Not Valid 1- Valid
Sp:	GPS Speed	[0-350]
Ns:	Nmea Stable Flag	0 – Not Stable 1 –Stable
Jl:	Jump Lock	0- Lock ON 2- Lock OFF
ALong:	Current Longitude	
ALat:	Current Latitude	
OLong:	Odometer Longitude	
OLat:	Odometer Latitude	

Answer Example: E:1 V:300 M:1 Mv:1, GPS:2 FIX:0 Valid:1 Sp:0 Ns:0 Jl:1 ALong:0.000000
ALat:0.000000 OLong:0.000000 OLat: 0.000000

14 FM6320 WITH LV-CAN 200 AND ALL-CAN 300 CAN ADAPTER

14.1 Purpose of Can Adapters LV-CAN200 and ALL-CAN300

LV-CAN200 is used to listening data from light vehicles, while ALL-CAN300 is used to listening data from any type of transport: light vehicles, Trucks, busses, agriculture and other special transport. With those adapters FM6320 device is able to collect and send vehicle data.

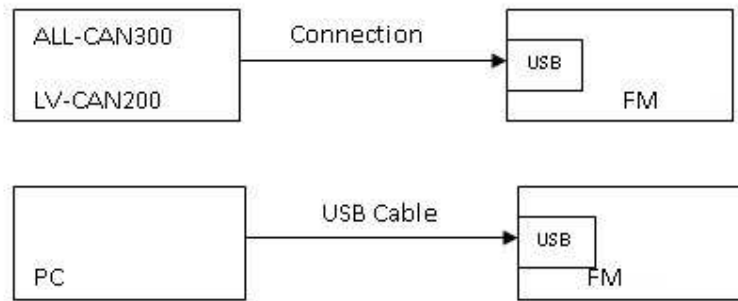

Figure 76 connection block diagram

FM6320 shares the same USB port for connecting adapter and configuring device with PC. LV-CAN200 and ALL-CAN300 Technical characteristics:

PARAMETER	VALUE
Supply voltage	9 to 50V
Power supply current	Average 10mA Max (peak) 100mA
Working temperature	-40..85 °C
Max working humidity	60 % (non condensate)

14.2 LV-CAN200 and ALL-CAN300 program number selection

LV-CAN200 or ALL-CAN300 must be set to program number which depends on vehicle model. **Needed program number is always written on LV-CAN200 or ALL-CAN300 mounting scheme.** Please contact Your Teltonika sales manager to get latest supported vehicle list and mounting scheme for your vehicle, please provide CAR manufacturer, model and year information.

14.2.1 LV-CAN200 and ALL-CAN300 program number configuration via SMS command

LV-CAN200 and ALL-CAN300 program number can be set remotely, using SMS command:

lvcansetprog X

X is new program number value.

14.2.2 Selecting LV-CAN200 and ALL-CAN300 program number manually

Steps to set program number:

- Hold SWITCH down till LED starts blinking
- Release the SWITCH
- Then LED starts blinking and counting first digit of program number, (one blink means digit 1, two blink digit 2 etc.)
- To stop counter push SWITCH
- Release the SWITCH, then LED starts blinking and counting second digit of program number
- To stop counter push SWITCH
- Release the SWITCH, then LED starts blinking and counting third digit on program number
- To stop counter push SWITCH
- Release SWITCH, if programming is succeeded LED will blink 10 times



Figure 77 Adapter signaling led

14.2.3 Program number logic change

Due to the growing number of supported cars, program numbers have exceeded 999. In order to maintain one number format, we are moving from 3 digits, to 4 digits program numbers.

In new LV-CAN200/ALL-CAN300 firmware (from 2017-09-01) all program numbers that were up to 999 are changed to start from 1000. So that further program numbers would continue the counting with 4 digit numbers.

However, all existing program numbers stays the same, it is just "1" appeared in front of them. Device still understands entered 3 digit program number (via SMS/GPRS), it will automatically add "1" before it. If you enter "247" - device will turn it into the "1247". In Bootloader it is only 4 digit format available, just add "1" in from of the needed program number.

Example:

If use oldest connection schemes where program number displayed as 3 digit program number:

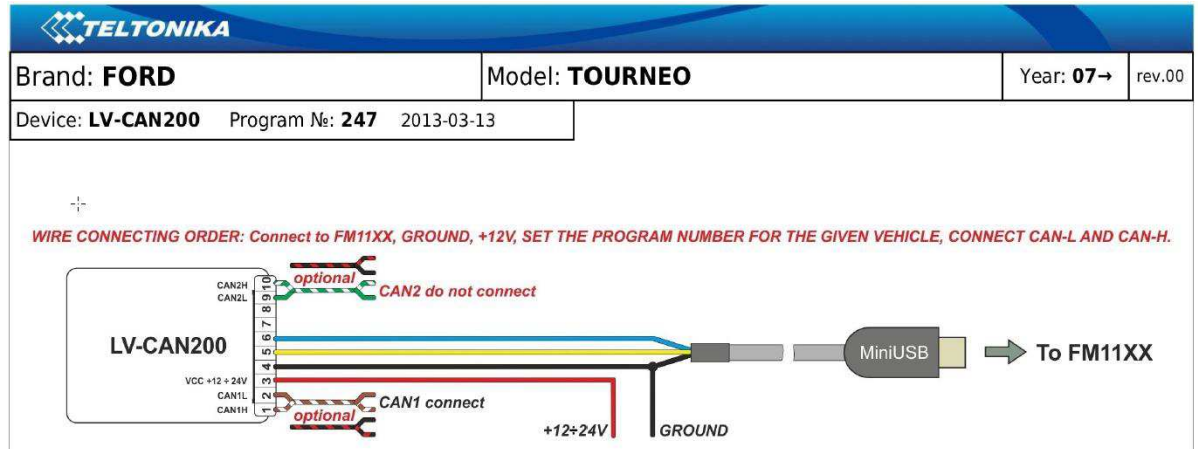

Using LV-CAN200/ALL-CAN300 Bootloader from soft version 2017-09-27 need add "1" before it:

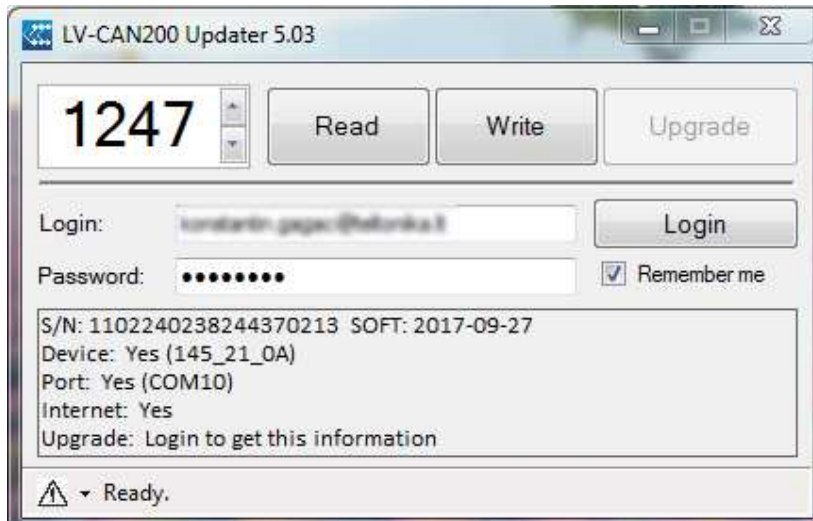

14.3 SIMPLE-CAN - contactless CAN-BUS reader

SIMPLE-CAN is contactless adapter used to read vehicle CAN data with LV-CAN200, ALL-CAN300. If LV-CAN200 or ALL-CAN300 connection requires two CAN lines to get all data, then you need two SIMPLE-CAN readers

TECHNICAL DETAILS

- Power supply voltage 9-63 V
- Power supply current:

Mode	12V	24V
Active	8.3 mA	4.3 mA
Standby	1.6 mA	0.91 mA
- CAN-BUS speeds from 33,33 to 500 kb/s
- Automatically sets CAN Low, CAN High polarity
- Automatically adjusts signal level and speed

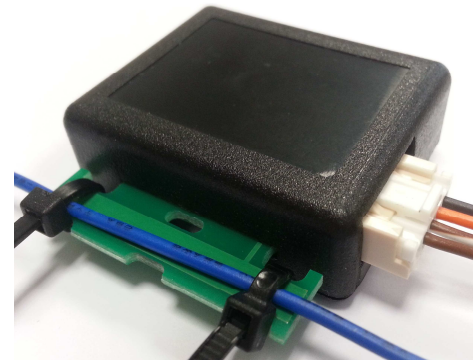

SIMPLE-CAN works in the **listening mode only**, so not all the data available on the CAN-BUS may be received using this solution. **The device automatically sets CAN L/H polarity**, but the calibration has to be always executed during installation process. Connection of previously calibrated unit to another car needs new calibration because the reader **automatically adjusts signal level and speed** to different CAN-BUSes. The device also **automatically adapts to the found noise level**.

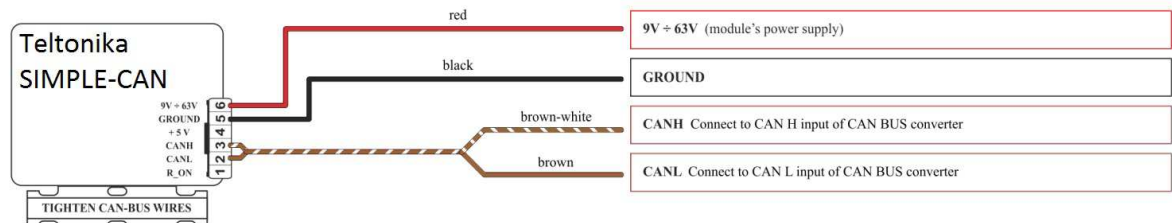

Figure 78 Simple can connection

After power supply connecting, LED shines continuously. It means that device awaits for calibration. **Calibration process** has to be carried out when CAN-BUS twisted pair is tightened on SIMPLE-CAN and when the ignition is ON. Please press the switch shortly and wait for the LED to start blinking every 1 second. Automatic calibration process takes up to 10 seconds depending on the vehicle's model. Correct calibration process is confirmed by LED's every 2 seconds blink (when the CAN-BUS is active). When the CAN-BUS enters sleep mode, SIMPLE-CAN device does it also and takes 1,6mA/12V. In the sleep mode LED does not shine. If after calibration process LED shines continuously, it means that device is not calibrated yet, CAN-BUS transmission has failed or ignition during calibration was not ON.

14.4 Connecting FM6320 Can adapters ALL-CAN300 and LV-CAN200

Connect USB Plug to FM6320 device, connect Light Vehicles Can adapter to other end of the cable.

Connect Light Vehicles Can adapter Pin 1 and Pin 2 to cars CAN bus. CAN interface location of the supported light vehicle is described on mounting scheme.

Connect car power supply lines to Pin 3 positive, Pin 4 Negative.

Pins 9,10 connection is optional it depends on exact car model.

For exact pinout see sticker on Light Vehicles Can adapter.

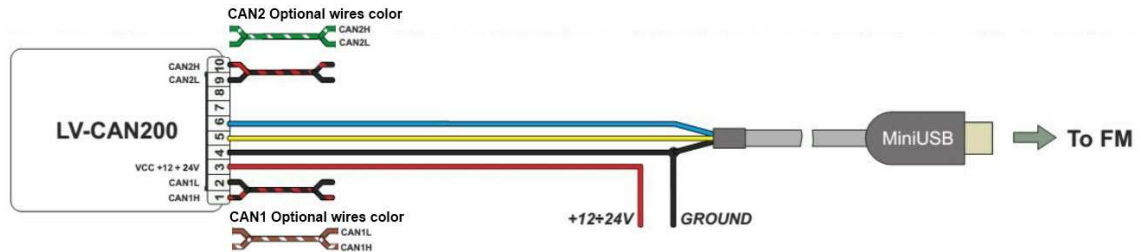

Figure 79 LV-CAN200 Adapter connection cable pinout

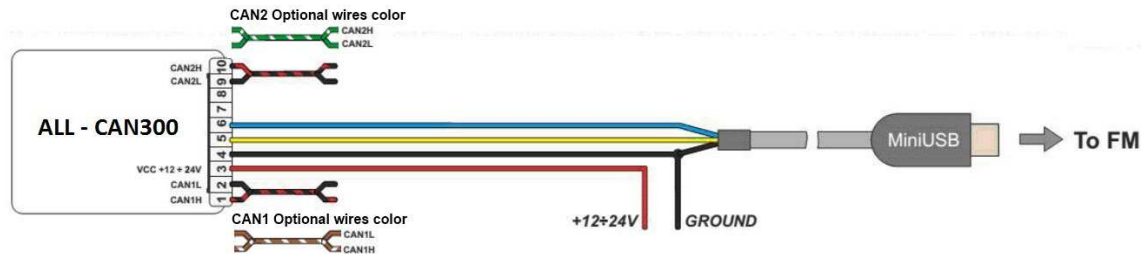

Figure 80 ALL-CAN300 Adapter connection cable pinout



Attention! Ordered LV-CAN200 and ALL-CAN300 packaging may vary:

1. Standard with mini-USB cable.
2. USB PCB (female) + mini-USB cable.



Attention! For detailed connection diagram of adapter to light vehicle please contact Teltonika, LTD sales representative and provide CAR manufacturer, model and year information.



**Attention! Do not swap CAN L and CAN H lines.
Do not swap power supply lines. Make sure that voltage do not exceeds 30V.
Power supply lines should be connected at the end of installation work.**

14.5 FM 6320 Configuraton

FM6320 shares the same USB port for connecting LV-CAN200 or ALL-CAN300 adapter and configuring device with PC.

FM6320 can be configured using “SCAN” function or “Offline Configuration”

SCAN function – is in use when FM6320 is connected to CAN adapter (Figure 79), then wait 10s (Note, that car engine must be started), disconnect adapter from FM6320, and connect PC USB cable to FM6320 Device (Figure79) It is very important not to disconnect FM6320 from power source during this operation, because if FM6320 is reconnected all received CAN bus data will be lost. FM6320 remembers received data from LV-CAN200 or ALL-CAN300 and at the end of the procedure when “SCAN” button is pressed, user will see all CAN data which is sent by adapter. Enable CAN data which needs send to server and save configuration pressing “Save” button.

To configure CAN data:

1. In car, connect LV-CAN200 or ALL-CAN300 to CAN bus and to the FM6320 device (Figure 80) wait 10 seconds. Note, that car engine must be started.
2. Disconnect LV-CAN200 or ALL-CAN300 from FM6320 and connect PC USB cable to FM6320 Device (Figure 81). It is very important not to disconnect FM6320 from power source, because then all CAN data will be lost.

Figure 81 Connect adapter LV-CAN200 to FM6320

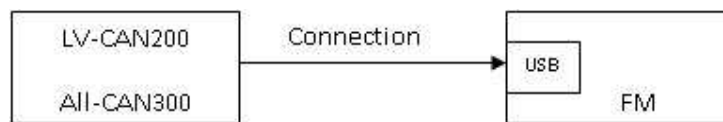
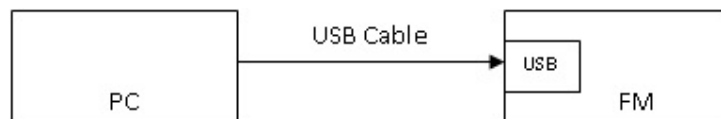

Figure 82 Connect FM6320 to PC and configure



CAN bus data which can be read from your car is shown in “Light or ALL Vehicles Can adapter supported cars” document.

Offline configuration – user can select which CAN data will be red from LV-CAN200 or ALL-CAN300 and directly sent to server without connection to adapter. Please note that parameters depend on vehicle manufacturer and vehicle model. Please for further information check “Light and All Vehicles Can adapter supported cars” document.

There are two types of operations with CAN data elements:

- Monitoring of CAN bus data
- CAN bus data event capturing

Monitoring method is used when user wants to receive CAN data on regular basis, for example every 20 seconds.

Event functionality is used to store additional AVL packet when state of CAN element is changing. For example Speed changes, low fuel level, engine temperate, etc.

Send data to server field – allows enabling CAN element so it is added to the AVL data packet and sent to the server. By default, all CAN elements are disabled and FM6320 records only GPS data.

It is possible to set CAN message priority: On Low Priority, On High Priority, and On Panic. Regular packets are sent as Low priority records. When low priority event is triggered, FM6320 makes additional record with indication what was the reason for that was CAN element change. When High priority is selected, module makes additional record with high priority flag and sends event packet immediately to the server by GPRS. Panic priority triggers same actions as high priority, but if GPRS fails, it sends AVL packet to server using SMS mode if SMS is enabled in SMS settings.

Data Acquisition Type – defines when to generate event – when value enters defined range, exits it or both, also is possible to select event which you want to generate then you change values, like crossing both values in high and low levels (Hysteresis).

High and Low levels – defines CAN value range. If CAN value enter or exits this range, FM6320 generates event by “Data Acquisition Type” settings. Figure 82 show example of FM6320 CAN configuration.

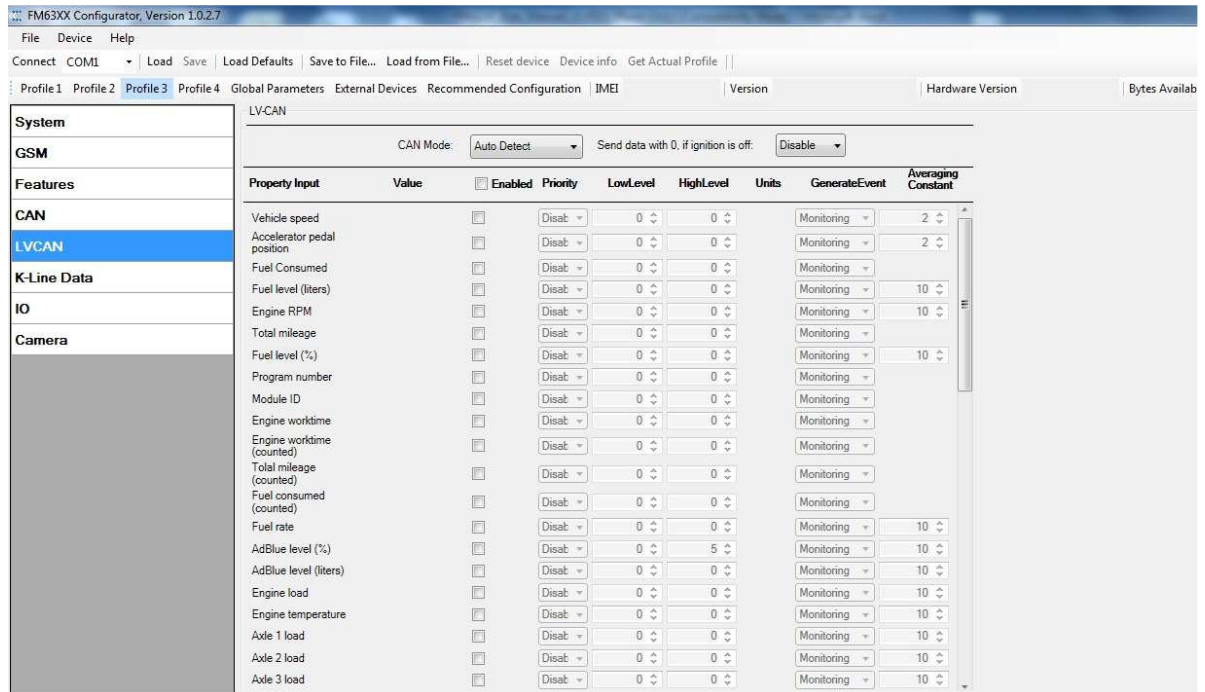

Figure 83 Configurator example

15 CAN

Controller Area Network (CAN or CAN-bus) is a computer network protocol and bus standard designed to allow microcontrollers and devices to communicate with each other and without a host computer. It was designed specifically for automotive applications but is now also used in other areas.

SAE J1939 and J1708* is the vehicle bus standard used for communication and diagnostics among vehicle components. Based on the same architecture FMS protocol dedicated to telematics systems is available. It has certain standardized parameters available, such as fuel

consumption, engine work-hours, etc. Please visit <http://www.fms-standard.com/> for more information and message structure.

The FMS-interface is an optional interface of different truck manufacturers. Supported information is dependent upon vehicle equipment. For the full information set, additional Electronic Control Units (ECU) may be required. Please contact the manufacturer or your dealer for more details.

Vehicle brands supported:

- Mercedes Benz
- Volvo
- MAN
- DAF
- Iveco
- Scania
- Renault

Available parameters:

- Total Fuel
- Total Distance
- Status of brake pedal *
- Engine Torque *
- Actual fuel
- Accelerator pedal position *
- Status engine brake
- Speed *
- RPM
- Engine hours
- Vehicle Weight *
- Fuel level
- Tachograph data *

* Availability of parameter depends on vehicle's model and configuration of FMS interface of the truck.

**J1708 is additional FMS protocol used by some vehicle manufacturers. If your vehicle supports J1939 and J1708 both protocols then you must disable J1708 in configuration to receive fuel data.*

15.1 General description

- CAN works if no USB cable is inserted and isn't in deep sleep mode;
- Uses six different speeds: 50 kbps, 100 kbps, 125 kbps, 250 kbps, 500 kbps, 1000kbps;
- Auto Baud rate detection;
- Filtering messages (StdId, ExtId) according to configuration;
- Using mask, filters required bytes;
- Different CAN configurations.

15.2 Configuration

Manual CAN data can be configured using "Manual CAN" in CAN tab, Figure 84 below (CAN configuration window).

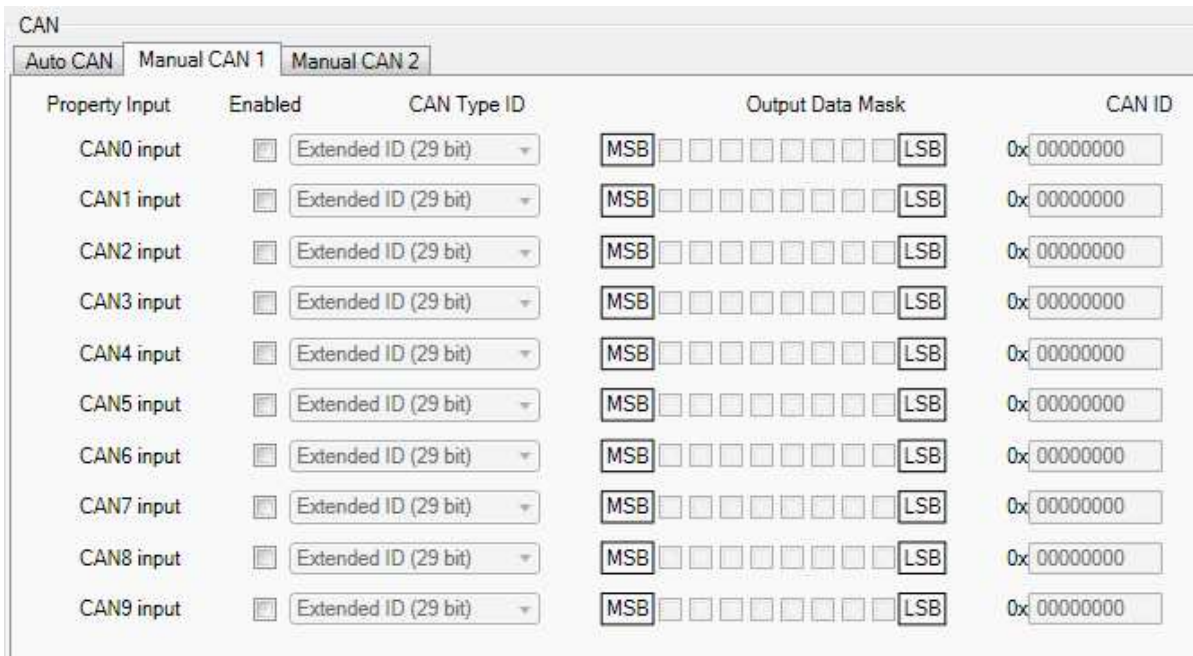

Figure 84 CAN configuration window

CAN message ID type: Message ID type (Figure 85) two types according to SAEJ1939 standard: Standard ID (value: 0 to 0x7FFh) and Extended ID (value: 0 to 0x1FFFFFFFh).

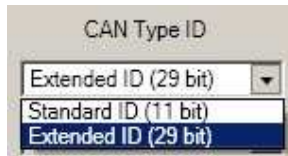

Figure 85 CAN message ID types

Message ID value is entered in hex format. This parameter is used to configure hardware message filter (Figure 86). All messages contain 8 bytes of data, to select particular data/bytes “Output Data Mask” is used, it’s done by ticking required bytes, only selected bytes are sent to server.



Figure 86 CAN message filter configuration

15.3 Example

A sample CAN message has the following structure: X18FEE9018FFFFFFFF23840300, where essential parts are ‘FEE9’ – identifier and ‘FFFFFFFF23840300’ – data bytes.

CAN messages are configured like any other I/O parameters. They consist of 4 identifier bytes and 8 data bytes. Below you will find a sample configuration for fuel consumption parameter:

ID type – is always 29 bits.

Output data mask – defines which data bytes are sent to the server (sometimes not all data bytes are necessary).

CAN ID – this is 4 byte identifier. Messages use 4 bytes, but the first and last bytes may differ in different vehicle models while the middle four bytes are the same for all vehicles. The first and last bytes may have any value. Because of this reason it is recommended to write FF in the first byte and the same in the last byte.



This information is provided only as an example and Teltonika takes no responsibility for information accuracy or damage that may be done to the vehicle or FM6320 module while integrating it.

Example:

All Mercedes Benz Actros 2 models with Vehicle Identification Number (VIN) starting with WDB93 have a possibility to connect FM6320 module to CAN bus. This can be done by connecting to special PSM module (which may or may not be included in the truck) or ground module of the vehicle. For CAN signal to be available, parameter 520 must be enabled in “kommunikationsschnittstelle” in the vehicle with Mercedes Stardiagnose.

CAN wires can be found on X5 connector located in the fuse box (Figure 87):

Pin 5: CAN Low signal (yellow wire)

Pin 2: CAN High signal (blue wire)

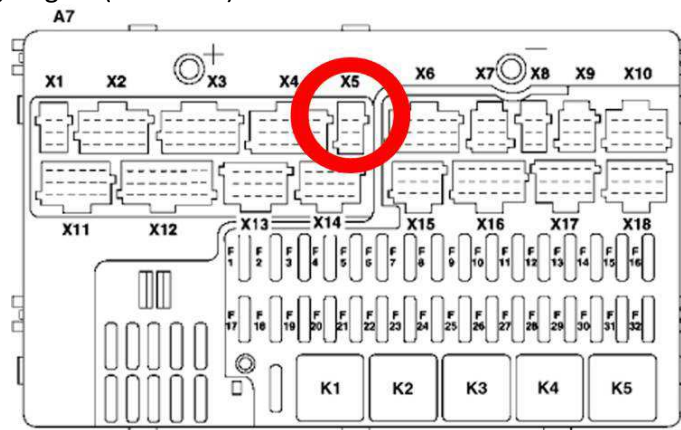

Figure 87 X5 plug on Mercedes Benz

In the example FM6320 will filter all CAN messages with identifier FFEE9FF (fuel consumption) (Figure 88).



Figure 88 CAN parameter configuration example



Note: Averaging constant cannot be used with CAN data, because this information comes in digital format.

Most parameters have certain resolution. FEE9 parameter has 0.5L/bit gain, so value that is sent to server has to be multiplied by 0.5.

Data parsing is preceded by selecting correct message from all available on CAN bus. FMS standard interface description indicates that fuel consumption is parameter with ID FEE9:

Table 52 FMS standard – fuel consumption

00FEE9								PGN Hex
65,257								PGN
1000 ms								Rep. Rate
Data Byte 1	Data Byte 2	Data Byte 3	Data Byte 4	Data Byte 5	Data Byte 6	Data Byte 7	Data Byte 8	Byte No.
Not used for FMS-Standard	Not used for FMS-Standard	Not used for FMS-Standard	Not used for FMS-Standard	Total fuel used 0,5 L/Bit gain 0 L offset 5.2.5.66 SPN 250	Total fuel used 0,5 L/Bit gain 0 L offset 5.2.5.66 SPN 250	Total fuel used 0,5 L/Bit gain 0 L offset 5.2.5.66 SPN 250	Total fuel used 0,5 L/Bit gain 0 L offset 5.2.5.66 SPN 250	Name Values Values Values SAE ref SPN

The example indicates how fuel consumption message is selected and how configuration impacts this selection (Figure 89).

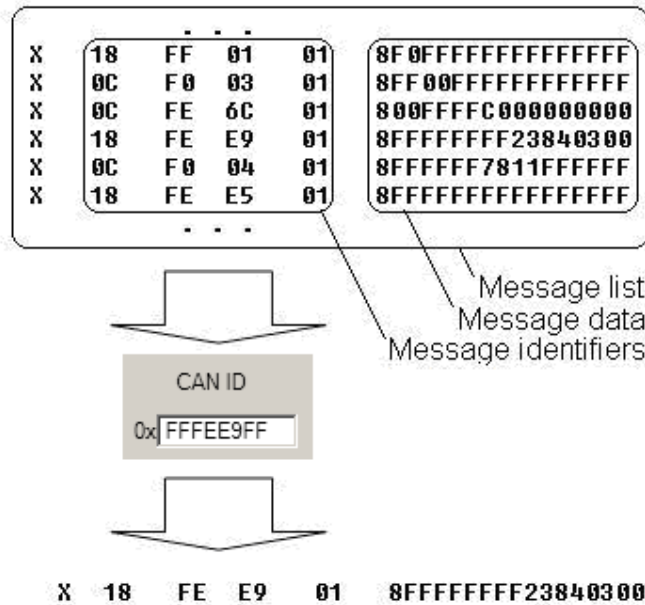

Figure 89 Example

When certain message is filtered, FM6320 checks which data bytes should be sent to server. Document indicates that 5-8 bytes are used in FMS standard.

Table 53 FMS standard – fuel consumption (5-8 bytes)

Data Byte 5				Data Byte 6				Data Byte 7				Data Byte 8				Byte No.																
8	7	6	5	4	3	2	1	8	7	6	5	4	3	2	1	8	7	6	5	4	3	2	1	8	7	6	5	4	3	2	1	Bit no.

Total fuel used 0,5 L/Bit gain 0 L offset 5.2.5.66 SPN 250	Total fuel used 0,5 L/Bit gain 0 L offset 5.2.5.66 SPN 250	Total fuel used 0,5 L/Bit gain 0 L offset 5.2.5.66 SPN 250	Total fuel used 0,5 L/Bit gain 0 L offset 5.2.5.66 SPN 250	Name Values Values Values SAE ref SPN
------------------------------------------------------------------------	------------------------------------------------------------------------	------------------------------------------------------------------------	------------------------------------------------------------------------	---------------------------------------------------------

X18FEE9018 FF FF FF FF 23 84 03 00

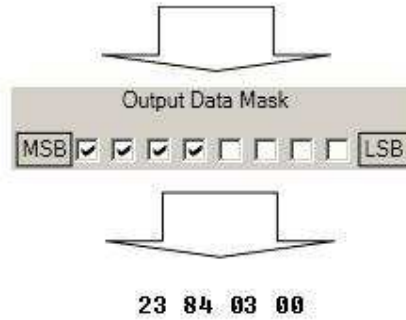

Figure 90 Example

Data bytes are filtered by selecting the checkboxes in Output data mask. Note, that configurator has them listed starting with MSB.

After message is filtered it is attached to the data packet and sent to the server. Values are returned in HEX. 00 03 84 23(HEX) = 230435(DEC). Notice, that data resolution is 0.5L/bit gain – value has to be multiplied by 0.5, therefore vehicle used a total 115217,5 liters of fuel.

15.4 FM6300 J1708 Connection

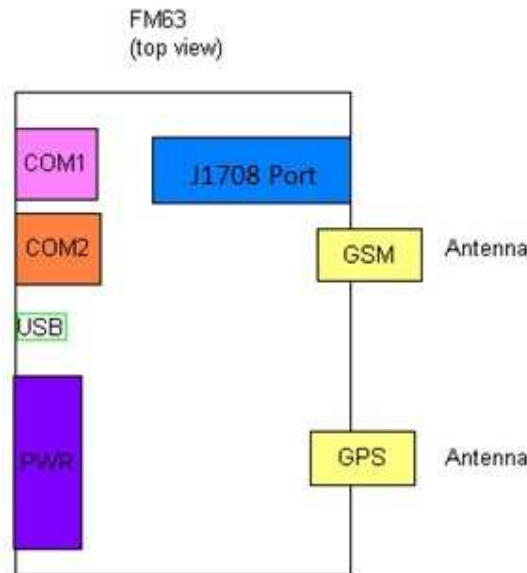

Figure 91 FM6300 diagram

J1708 Connector
(top view)

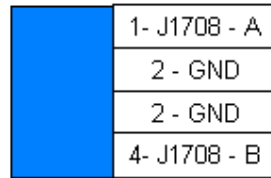

Figure 92 J1708 Connector diagram

Connection with Vehicle port

Check Vehicle diagnostic port pinout diagram and connect like is shown below.

FM63	Vehicle
J1708-A	J1708A J1708+
J1708-B	J1708B and J1708-

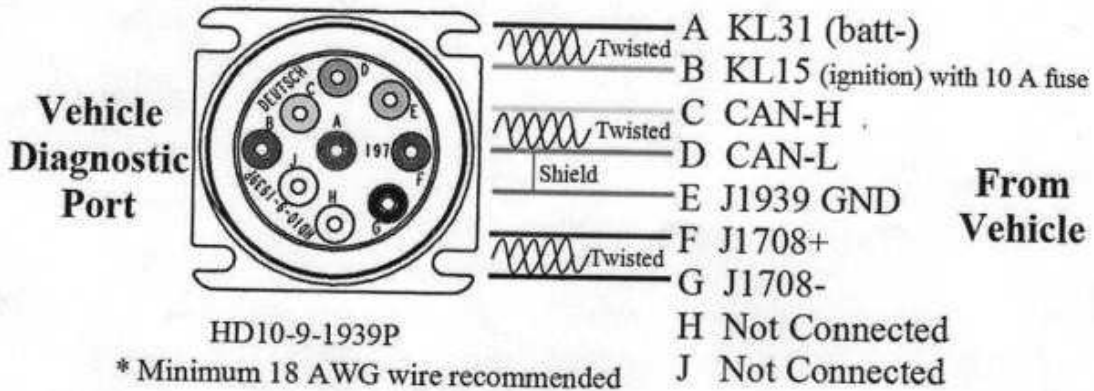

Figure 93 Example of Diagnostic port

15.5 Software Configuration of FM6300 with J1708

Firmware version: 00.00.24 or above

Configurator version: 1.0.0.12

Step 1

Enable J1708 Line in External Devices Tab

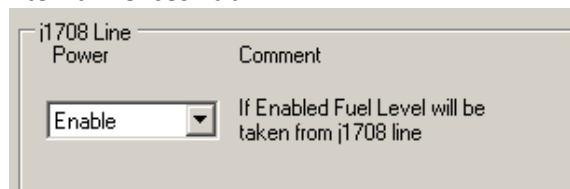

Figure 94

Option 1

Enable Fuel Level in AutoCAN

Fuel Consumption	Engine total fuel used	0 liters	On Low Prior	Monitoring	0	0
Dash Display	Fuel level 1	0 %	On Low Prior	Monitoring	0	0

Figure 95

For AVL ID please consult FMS document.

Option 2

Enable PGN in manual CAN

Property Input	Enabled	CAN Type ID	Output Data Mask								CAN ID		
CAN0 input	Low	Extended ID (29 bit)	MSB	<input type="checkbox"/>	<input checked="" type="checkbox"/>	<input type="checkbox"/>	<input type="checkbox"/>	<input type="checkbox"/>	<input type="checkbox"/>	<input type="checkbox"/>	<input type="checkbox"/>	LSB	0x FFFEFCFF
CAN1 input	Low	Extended ID (29 bit)	MSB	<input type="checkbox"/>	<input type="checkbox"/>	<input type="checkbox"/>	<input type="checkbox"/>	<input checked="" type="checkbox"/>	<input checked="" type="checkbox"/>	<input checked="" type="checkbox"/>	<input checked="" type="checkbox"/>	LSB	0x FFEE99FF

Figure 96

15.6 AutoCAN description

AutoCAN function allows user to automatically scan for available messages on CAN bus and configure CAN data sending to server. In order to configure AutoCAN connect FM6320 to computer with Port ½ cable. Launch FM6320xx configurator version 1.1.1.7 or higher. Push “Connect” button, then „CAN“ button (Figure 97). CAN configuration menu will be opened.

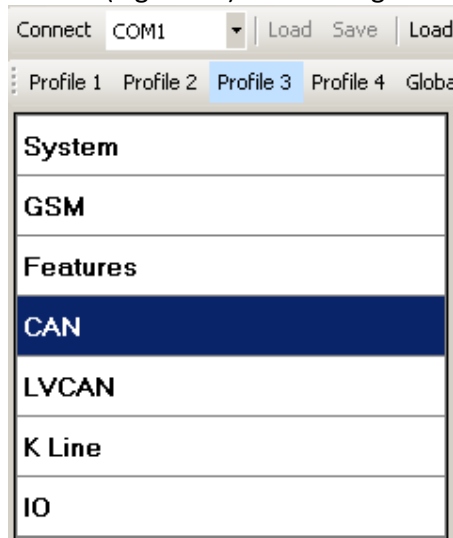

Figure 97 Entering CAN configuration

- SCAN scans once for available messages on CAN bus;
- Monitoring – toggles scanning of messages on CAN bus every 3 seconds;
- Offline Configuration – enables CAN configuration when FM6320xx is not connected to CAN bus;
- Auto CAN tab – configure CAN by selecting available messages from CAN bus;
- Manual CAN tab – Configure CAN by manually entering CAN message ID and data mask;

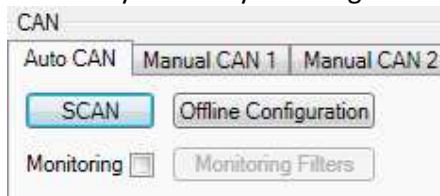

Figure 98 CAN configuration menu

15.6.1 Configuration

To start CAN configuration push “SCAN” button. A table of all available CAN messages will appear (Figure 98). Description of columns:

- Category – shows CAN message;
- Parameter – shows configurable parameter name;
- Value – shows scanned value of parameter;
- Send data to server – allows to choose the type of data when it’s generated:
 - Disabled – Data will not be collected
 - On low priority – records will be generated as low priority events;

- On high priority – records will be generated as high priority events and immediately sent to server via GPRS (if GPRS is available);
- On panic - records will be generated as panic priority events and immediately sent to server via GPRS, if GPRS is not available records will be sent via SMS messages;
- Data acquisition type – allows to choose when records are generated:
 - Monitoring – monitors data;
 - On change – record is generated when parameter value is changed;
 - Hysteresis – record is generated when increasing parameter value becomes higher than High value, and decreasing becomes less than Low value
 - Event on exit – record is generated when parameter value becomes higher than High value or lower than Low value;
 - Event on entrance – record is generated when parameter value becomes between High and Low values;
 - Event on both – record is generated when parameter value crosses High or Low values;
- Low – allows to choose low value for Data acquisition;
- High – allows to choose High level for Data acquisition;

Monitoring filters						
Category	Parameter	Value	Send Data To Server	Data Acquisition Type	Low	High
Cruise Control/Vehicle Speed	Brake switch	Pedal released	Disable	Monitoring		
	Wheel based speed	0 km/h	Disable	Monitoring	0	0
	Cruise control active	Off/disabled	Disable	Monitoring		
	Clutch switch	Pedal released	Disable	Monitoring		
	PTO state	Off/disabled	Disable	Monitoring		
Electronic Engine Controller #2	Accelerator pedal position 1	0 %	Disable	Monitoring	0	0
	Engine Percent Load At Current Speed	0 %	Disable	Monitoring	0	0
Fuel Consumption	Engine total fuel used	0 liters	Disable	Monitoring	0,0	0,0
Dash Display	Fuel level 1	0 %	Disable	Monitoring	1	1
Electronic Engine Controller #1	Engine speed	0 rpm	Disable	Monitoring	0,000	0,000

Figure 99 CAN data table

15.6.2 CAN monitoring

To start CAN bus monitoring mark *Monitoring* check box. Table of available CAN messages will appear (Figure 99). Data from CAN bus will be updated every 3 seconds. In order to see only desired data open “Monitoring filters” menu (Figure 100).

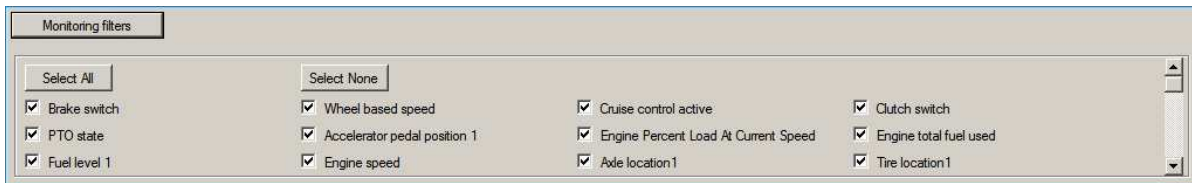

Figure 100 Monitoring filters

Monitoring filters menu allows choosing which data will be shown in configuration menu. To enable/disable particular data monitoring use checkbox next to data name. To enable all data monitoring click *Select all* , to disable all data monitoring click *Select none*.



Note: CAN monitoring is FM6320 configurator function; it does not enable data sending to server. In order to configure data sending to server refer to Configuration section.

15.6.3 Offline configuration

When FM6320 device is not connected to CAN bus you can configure CAN data sending by pushing “Offline configuration” button. When offline configuration is enabled a configuration table of all FMS standard CAN data is shown.

15.6.4 AutoCAN ID list

Table 54 AutoCAN ID list

Category name	Par Nr in P:FMS:	Par Nr. In P:FMSDAT:	(signal) name	Size (Bytes)	Param IO ID	Value range
65265 – Cruise Control/Vehicle Speed	1	1	Brake switch	1	79	0-1 0 = pedal released 1 = pedal depressed
	2	2	wheel based speed	4	80	0-65536 (km/h)*
	3	3	cruise control active	1	81	0-1 0 = switched off 1 = switched on
	4	4	clutch switch	1	82	0-1 0 = pedal released 1 = pedal depressed
	5	5	PTO state	1	83	0-3 0 = off/disabled 1 = Set 2 = not available
61443 – Electronic Engine Controller #2	6	6	accelerator pedal position 1 X	4	84	0-102 (%)*
	7	7	Engine Percent Load At Current Speed X	1	85	0-125 (%)*
65257 – Fuel Consumption	8	8	Engine total fuel used	4	86	0 – 2105540607,5 (Liters)*
65276 – Dash Display	9	9	fuel level 1 X	4	87	1-100 (%)*
61444 – Electronic Engine Controller #1	10	10	engine speed X	4	88	0 – 8031,875 (rpm)*
65258 – Vehicle	[11-25]	11	Axle location	1		1-15

Category name	Par Nr in P:FMS:	Par Nr. In P:FMSDAT:	(signal) name	Size (Bytes)	Param IO ID	Value range
Weight **	(Tire No 1 - 15)		Tire location	1		1-15
			Axle weight	4	[89 – 103]	32766 (kg)*
65253 – Engine Hours, Revolutions: HOURS	26	12	Engine total hours of Operation X	4	104	0 – 214748364 (Hours)*
65260 – Vehicle Identification	27	13	vehicle identification number X	Max 24	[105 - 108]	Max 24 ASCII bytes
64977 – FMS Standard interface	28	14	SW-version supported X	4	109	4 ASCII bytes (Version format – ab.cd)
	29	15	Diagnostics supported X	1	110	0-3 0 = diagnostics is not supported 1 = diagnostics is supported 2 = reserved 3 = don't care
	30	16	Requests supported X	1	111	0-3 0 = request is not supported 1 = request is supported 2 = reserved 3 = don't care
65217 - High Resolution Vehicle Distance	31	17	High resolution total vehicle distance X	4	112	0 - 21055406 km*
65216 - Service Information	32	18	Service distance	4	113	-160 635 – 167040 km*
65132 - Tachograph	33	19	Vehicle motion X	1	114	0 – Motion Not Detected 1 – Motion Detected
	34	20	driver 2 working state X	1	115	0 – Rest 1 – Driver Available 2 – Work 3 - Drive 4 – Error 5 – not available
	35	21	driver 1 working state X	1	116	0 – Rest 1 – Driver Available 2 – Work 3 - Drive 4 – Error 5 – not available
	36	22	Vehicle overspeed	1	117	0 – No Overspeed 1 – Overspeed
	37	23	Driver 1 time rel. states	1	118	0 – Normal 1 – 15min bef. 4,5h 2 – 4,5h reached 3 – 15min bef. 9h 4 – 9h reached 5 – 15min bef. 16h 6 – 16h reached 7 – Error 8 – not available
	38	24	Driver 2 time rel. states	1	119	0 – Normal 1 – 15min bef. 4,5h 2 – 4,5h reached

Category name	Par Nr in P:FMS:	Par Nr. In P:FMSDAT:	(signal) name	Size (Bytes)	Param IO ID	Value range
						3 – 15min bef. 9h 4 – 9h reached 5 – 15min bef. 16h 6 – 16h reached 7 – Error 8 – not available
65132 - Tachograph	39	25	Driver 1 card X	1	120	0 – Card Not Present 1 – Card Present
	40	26	Driver 2 card X	1	121	0 – Card Not Present 1 – Card Present
	41	27	Direction indicator	1	122	0 – Forward 1 – Reverse
	42	28	Tachograph performance X	1	123	0 – Normal Performance 1 – Performance Analysis
	43	29	Handling information X	1	124	0 – No Handling Information 1 – Handling Information
	44	30	System event X	1	125	0 – No Tacho Event 1 – Tacho Event
	45	31	Tachograph vehicle speed X	2	126	[0 – 65000] – Tacho Vehicle Speed km/h*
65262 - Engine Temperature 1	46	32	engine coolant temperature X	1	127	[-40 – 210] oC – Engine Coolant Temperature*
65269 - Ambient Conditions	47	33	Ambient Air Temperature X	2	128	[-273 – 1770]oC – Ambient Air Temperature*
65131 - Driver's Identification	48	34	Driver 1 Identification	32	129,130,131	24 ASCII Bytes per Driver ID
65131 - Driver's Identification	49		Driver 2 Identification X	32	132,133,134	24 ASCII Bytes per Driver ID
65266 – Fuel Economy	50	35	Fuel rate X	4	135	[0 – 3212,75] litres/h*
	51	36	Instantaneous Fuel Economy X	4	136	[0 – 125.5 km/litre]*
64932 - PTO Drive Engagement	52	37	At least one PTO engaged	1	137	0 – No PTO Drive is Engaged 1 – At least one PTO drive is engaged 2 – Error 3 – not available
64777 - High Resolution Fuel Consumption (Liquid)	53	38	High resolution engine total fuel used	4	138	[0 - 4211081,215] litres*

Brake switch:

Switch signal which indicates that the driver operated brake foot pedal is being pressed. This brake foot pedal is controlling the vehicles' service brake (total vehicle braking application, not park brakes). It is necessary for safe drivetrain behavior that the switch activates before the physical braking components are activated (i.e. Disengage the cruise control function prior to the activation of friction brakes).

00 – Brake pedal released

01 – Brake pedal pressed

10 – Error

11 – Not Available

Data Length: 2 bits

Resolution: 4 states/2 bit, 0 offset

Data Range: 0 to 3 Operational Range: same as data range

Type: Measured

Supporting information:

PGN 65265

Note: Firmware captures only [0,1] values. [2,3] – are ignored.

Wheel based speed:

Speed of the vehicle as calculated from wheel or tailshaft speed.

Data Length: 2 bytes

Resolution: 1/256 km/h per bit, 0 offset

Data Range: 0 to 250.996 km/h Operational Range: same as data range

Type: Measured

Supporting information:

PGN 65265

Note: Firmware sends data as U32, so value after floating point is ignored. Also value sent to server is already adjusted with bitgain.

Cruise control active:

Cruise control is switched on. It is not ensured that the engine is controlled by cruise control, as in the case of a large driver's demand the engine is controlled by the driver while cruise control is active(maximum selection of cruise control and driver's demand). The cruise control is set to 0 if a switch off condition occurs.

00 – Cruise control switched off

01 – Cruise control switched on

10 – Error

11 – Not available

Data Length: 2 bits

Resolution: 4 states/2 bit, 0 offset

Data Range: 0 to 3 Operational Range: same as data range

Type: Measured

Supporting information:

PGN 65265

Note: Firmware captures only [0,1] values. [2,3] – are ignored.

Clutch switch:

Switch signal which indicates that the clutch pedal is being pressed. It is necessary for a safe drivetrain behavior that the clutch switch is set before the clutch is opened (cruise control function).

00 – Clutch pedal released

01 – Clutch pedal pressed

10 – Error

11 – Not available

Data Length: 2 bits

Resolution: 4 states/2 bit, 0 offset

Data Range: 0 to 3 Operational Range: same as data range

Type: Measured

Supporting information:

PGN 65265

Note: Firmware captures only [0,1] values. [2,3] – are ignored.

PTO state information:

This parameter is used to indicate the current state or mode of operation by the power takeoff (PTO) governor. In lieu of support for PTO Drive Engagement parameters, this parameter may represent the status of a PTO drive. The broadcasting device must ensure that each achieved state is conveyed in at least one message broadcast before a transition to another state is allowed.

00000 Off/Disabled

00001 Hold

00010 Remote Hold

00011 Standby

00100 Remote Standby

00101 Set

00110 Decelerate/Coast

00111 Resume

01000 Accelerate

01001 Accelerator Override

01010 Preprogrammed set speed 1

01011 Preprogrammed set speed 2

01100 Preprogrammed set speed 3

01101 Preprogrammed set speed 4

01110 Preprogrammed set speed 5

01111 Preprogrammed set speed 6

10000 Preprogrammed set speed 7

10001 Preprogrammed set speed 8

10010 PTO set speed memory 1

10011 PTO set speed memory 2

10100-11110 not defined

11111 Not available

Off/Disabled 00000b — Used to indicate that the PTO governor enable switch is in the off position.

Hold 00001b — used to indicate that the PTO governor is active and currently maintaining a captured operating speed.

Remote Hold 00010b — used to indicate that the remote PTO governor is active and the PTO governor is currently maintaining a captured operating speed.

Standby 00011b — used to indicate that the PTO governor device enable switch is in the ON position and it is possible to manage the PTO governor.

Remote Standby 00100b — used to indicate that the remote PTO governor device enable switch is in the ON position and it is possible to manage the PTO governor.

Set 00101b — Used to indicate that the PTO governor is establishing current speed as the operating speed (captured value).

Decelerate/Coast 00110b — Used to indicate that the PTO governor is in the process of ramping down, or coasting, from the current operating speed.

Resume 00111b — Used to indicate that the PTO governor is in the process of resuming the operating speed to a previously captured value.

Accelerate 01000b — Used to indicate that the PTO governor is in the process of ramping up the operating speed.

Accelerator Override 01001b—used to indicate that the PTO governor is active but for the present time the engine is controlled by a large driver’s demand.

Preprogrammed PTO Governor Set Speed 1 01010b—used to indicate that the PTO device is establishing a first preprogrammed PTO governor set speed (user programmable) as the current operating speed.

Preprogrammed PTO Governor Set Speed 2 01011b—used to indicate that the PTO device is establishing a second preprogrammed PTO governor set speed (user programmable) as the current operating speed.

Preprogrammed PTO Governor Set Speed 3 01100b —used to indicate that the remote PTO device is establishing a third preprogrammed PTO governor set speed (user programmable) as the current operating speed.

Preprogrammed PTO Governor Set Speed 4 01101b —used to indicate that the remote PTO device is establishing a fourth preprogrammed PTO governor set speed (user programmable) as the current operating speed.

Preprogrammed PTO Governor Set Speed 5 01110b —used to indicate that the remote PTO device is establishing a fifth preprogrammed PTO governor set speed (user programmable) as the current operating speed.

Preprogrammed PTO Governor Set Speed 6 01111b—used to indicate that the remote PTO device is establishing a sixth preprogrammed PTO governor set speed (user programmable) as the current operating speed.

Preprogrammed PTO Governor Set Speed 7 10000b —used to indicate that the remote PTO device is establishing a seventh preprogrammed PTO governor set speed (user programmable) as the current operating speed.

Preprogrammed PTO Governor Set Speed 8 10001b —used to indicate that the remote PTO device is establishing a eighth preprogrammed PTO governor set speed (user programmable) as the current operating speed.

PTO set speed memory 1 10010b —Used to indicate that PTO set speed memory one set state is active.

PTO set speed memory 2 10011b — Used to indicate that PTO set speed memory two set state is active.

Data Length: 5 bits

Resolution: 32 states/5 bit, 0 offset

Data Range: 0 to 31 Operational Range: same as data range

Type: Status

Supporting information:

PGN 65265

Note: Firmware captures full data range [0x00..0x1F]. All states.

Accelerator pedal position 1:

The ratio of actual position of the analog engine speed/torque request input device (such as an accelerator pedal or throttle lever) to the maximum position of the input device. This parameter is intended for the primary accelerator control in an application. If an application has only one accelerator control, use SPN 91.

For on-highway vehicles, this will typically be the operator’s accelerator pedal. Although it is used as an input to determine powertrain demand, it also provides anticipatory information to transmission and ASR algorithms about driver actions.

In marine applications, this will typically be the operator’s throttle lever.

If a low idle validation switch is used in conjunction with accelerator pedal position 1, use Accelerator Pedal Low Idle Switch 1, SPN 558.

Data Length: 1 byte

Resolution: 0.4 %/bit, 0 offset

Data Range: 0 to 100 % Operational Range: same as data range

Type: Measured

Supporting information:

PGN 61443

Note: Firmware sends data as U32 (although it would be enough to send as 1B), so value after floating point is ignored. Also value sent to server is already adjusted with bitgain.

Engine percent load at current speed:

The ratio of actual engine percent torque (indicated) to maximum indicated torque available at the current engine speed, clipped to zero torque during engine braking.

Data Length: 1 byte

Resolution: 1 %/bit, 0 offset

Data Range: 0 to 250 % Operational Range: 0 to 125%

Type: Status

Supporting information:

PGN 61443

Note: Since bitgain is 1%/bit – raw data is sent to server. But, data is limited to max 125 (0x7D). If captured data is higher than 125 (decimal) – data is truncated to 125.

Engine total fuel used:

Accumulated amount of fuel used during vehicle operation.

Data Length: 4 bytes

Resolution: 0.5 L/bit, 0 offset

Data Range: 0 to 2,105,540,607.5 L Operational Range: same as data range

Type: Measured

Supporting information:

PGN 65257

Note: Value sent to server is already adjusted with bitgain. Since data is sent as U32, value after floating point is ignored.

Fuel level 1:

Ratio of volume of fuel to the total volume of fuel storage container.

When Fuel Level 2 (SPN 38) is not used, Fuel Level 1 represents the total fuel in all fuel storage containers. When Fuel

Level 2 is used; Fuel Level 1 represents the fuel level in the primary or left-side fuel storage container.

Data Length: 1 byte

Resolution: 0.4 %/bit, 0 offset

Data Range: 0 to 100 % Operational Range: same as data range

Type: Measured

Supporting information:

PGN 65276

Note: Value sent to server is already adjusted with bitgain. Since data is sent as U32, value after floating point is ignored.

Engine speed:

Actual engine speed which is calculated over a minimum crankshaft angle of 720 degrees divided by the number of cylinders.

Data Length: 2 bytes

Resolution: 0.125 rpm/bit, 0 offset

Data Range: 0 to 8,031.875 rpm Operational Range: same as data range

Type: Measured

Supporting information:

PGN 61444

Note: Value sent to server is already adjusted with bitgain. Since data as sent as U32, value after floating point is ignored.

Axle weight:

Total mass imposed by the tires on the road surface at the specified axle.

Data Length: 2 bytes

Resolution: 0.5 kg/bit, 0 offset

Data Range: 0 to 32,127.5 kg Operational Range: same as data range

Type: Measured

Supporting information:

PGN 65258

Note: Value sent to server is already adjusted with bitgain. Data sent to server is a sum of all weights per tire per specific axle [1-15]. I.e. axle[1].total_weight, axle[2].total_weight etc. Since data is sent as U32, value after floating point is ignored.

Engine total hours of operation:

Accumulated time of operation of engine.

Data Length: 4 bytes

Resolution: 0.05 hour/bit, 0 offset

Data Range: 0 to 210,554,060.75 hour. Operational Range: same as data range

Type: Measured

Supporting information:

PGN 65253

Note: Value sent to server is already adjusted with bitgain. Since data as sent as U32, value after floating point is ignored.

Vehicle identification number:

Vehicle Identification Number (VIN) as assigned by the vehicle manufacturer.

NOTE The ASCII character "*" is reserved as a delimiter.

Data Length: Variable – up to 200 characters ("*" delimited)

Resolution: ASCII, 0 offset

Data Range: 0 to 255 per byte Operational Range: same as data range

Type: Measured

Supporting information:

PGN 65260

Note: Firmware expects VIN to fit into 24 bytes. According to captured VIN length either 1/2/3 IO ID's will be sent to server (8 Bytes each). I.e. if VIN length <= 8, only one IO ID (105) will be sent

to server, if VIN length >9 and <= 16, then two IO ID's will be sent to server (105,106), and if VIN length > 16 and <= 24 then three IO ID's will be sent to server (105,106,107).

FMS-standard SW version supported:

Information that identifies which issue level of the FMS-standard document the software included in the FMS gateway

supports. Four bytes, representing xx.yy type revision level identification.

Information to be ASCII equivalent of the numeric revision level of the FMS document, 00.01 to 99.99. The first released version will be 01.00.

Note:

Byte 2 and byte 3 represents the SW version supported for trucks. Version number in the format ab.cd where Byte 2 represents "a" ASCII and Byte 3 represents "b" ASCII.

Byte 4 and byte 5 represents the SW version supported for bus and coaches; version number in the format ab.cd where

Byte 4 represents "c" ASCII and Byte 5 represents "d" ASCII.

Data Length: 4 bytes

Resolution: ASCII, 0 offset

Data Range: 0 to 255 per byte Operational Range: same as data range

Type: Measured

Supporting information:

PGN 64977

Note: Firmware sends 4 bytes, which should be interpreted as xx.yy.

FMS-standard diagnostics supported:

Status signal which indicates if the FMS Vehicle Interface (FMS Gateway) supports the handling of diagnostic messages from the vehicle network onto the FMS network.

The FMS gateway does NOT support the re-broadcast of diagnostics messages present on the vehicle network.

If this 'FMS-standard Diagnostics Supported' feature is supported by the FMS Gateway, the FMS Gateway will support the requests for diagnostics information (from the FMS device) onto the vehicle network and pass the responses onto the FMS network.

Note: This feature of the FMS Gateway is independent of the 'FMS-standard Requests Supported'. The FMS Gateway may support diagnostics without supporting the 'FMS-standard Requests Supported' function, or visa-versa.

00 Diagnostics Is Not Supported

01 Diagnostics Is Supported

10 Reserved

11 Don't care

Data Length: 2 bits

Resolution: 4 states/2 bit, 0 offset

Data Range: 0 to 3 Operational Range: same as data range

Type: Status

Supporting information:

PGN 64977

Note: Firmware captures all values [0x00-0x03].

FMS-standard requests supported:

Status signal which indicates if the FMS Vehicle Interface (FMS Gateway) will respond to requests from the FMS device for the PGNs listed in the FMS Interface Specification.

This mode is to support FMS gateway devices that only operate in a 'Request' mode.

The FMS PGNs may also be broadcast periodically in this mode.

The FMS Gateway will NOT support the requests for information not included in the FMS Interface Specification onto the vehicle network."

00 On request mode is not supported

01 On request mode is supported

10 Reserved

11 Don't care

Data Length: 2 bits

Resolution: 4 states/2 bit, 0 offset

Data Range: 0 to 3 Operational Range: same as data range

Type: Status

Supporting information:

PGN 64977

Note: Firmware captures all values [0x00-0x03].

High resolution total vehicle distance:

Accumulated distance traveled by the vehicle during its operation.

NOTE – See SPN 245 for alternate resolution.

Data Length: 4 bytes

Resolution: 5 m/bit, 0 offset

Data Range: 0 to 21,055,406 km Operational Range: same as data range

Type: Measured

Supporting information:

PGN 65217

Note: Value sent to server is already adjusted with bitgain.

Service distance:

The distance which can be traveled by the vehicle before the next service inspection is required. A negative distance is transmitted if the service inspection has been passed. The component that requires service is identified by the service component identification (see SPN 911-913, 1379, and 1584).

Data Length: 2 bytes

Resolution: 5 km/bit, -160,635 km offset

Data Range: -160,635 to 160,640 km Operational Range: same as data range

Type: Measured

Supporting information:

PGN 65216

Note: Value sent to server is already adjusted with bitgain.

Vehicle motion:

Indicates whether motion of the vehicle is detected or not.

00 Vehicle motion not detected

01 Vehicle motion detected

10 – Error

11 – Not available
 Data Length: 2 bits
 Resolution: 4 states/2 bit, 0 offset
 Data Range: 0 to 3 Operational Range: same as data range
 Type: Measured
 Supporting information:
 PGN 65132
 Note: Firmware captures all values [0x00-0x03].

Driver 1/2 working state:

State of work of the driver.
 000 Rest – sleeping
 001 Driver available – short break
 010 Work – loading, unloading, working in an office
 011 Drive – behind wheel
 100-101 Reserved
 110 Error
 111 Not available
 Data Length: 3 bits
 Resolution: 8 states/3 bit, 0 offset
 Data Range: 0 to 7 Operational Range: same as data range
 Type: Status
 Supporting information:
 PGN 65132
 Note: Firmware captures all values [0x00-0x07].

Vehicle overspeed:

Indicates whether the vehicle is exceeding the legal speed limit set in the tachograph.
 00 No overspeed
 01 Overspeed
 10 Error
 11 Not available
 Data Length: 2 bits
 Resolution: 4 states/2 bit, 0 offset
 Data Range: 0 to 3 Operational Range: same as data range
 Type: Measured
 Supporting information:
 PGN 65132
 Note: Firmware captures all values [0x00-0x03].

Driver 1/2 time related states:

Indicates if the driver approaches or exceeds working time limits (or other limits).
 0000 Normal/No limits reached
 0001 Limit #1 – 15 min before 4 ½ h
 0010 Limit #2 – 4 ½ h reached
 0011 Limit #3 – 15 min before 9 h
 0100 Limit #4 – 9 h reached
 0101 Limit #5 – 15 min before 16 h (not having 8h rest during the last 24h)

0110 Limit #6 – 16 h reached
0111-1100 Reserved
1101 Other
1110 Error
1111 Not available
Data Length: 4 bits
Resolution: 16 states/4 bit, 0 offset
Data Range: 0 to 15 Operational Range: same as data range
Type: Measured
Supporting information:
PGN 65132
Note: Firmware captures all values [0x00-0x0F].

Driver card, driver 1/2:

Indicates the presence of a driver card
00 – Driver card not present
01 – Driver card present
10 – Error
11 – Not available
Data Length: 2 bits
Resolution: 4 states/2 bit, 0 offset
Data Range: 0 to 3 Operational Range: same as data range
Type: Measured
Supporting information:
PGN 65132
Note: Firmware captures all values [0x00-0x03].

Direction indicator:

Indicates the direction of the vehicle.
00 – Forward
01 – Reverse
10 – Error
11 – Not available
Data Length: 2 bits
Resolution: 4 states/2 bit, 0 offset
Data Range: 0 to 3 Operational Range: same as data range
Type: Measured
Supporting information:
PGN 65132
Note: Firmware captures all values [0x00-0x03].

Tachograph performance:

Indicates the tachograph performance; including electronic or mechanical analysis, instrument analysis, speed sensor analysis, mass storage analysis, and printer analysis.
00 – Normal performance
01 – Performance analysis
10 – Error
11 – Not available

Data Length: 2 bits
 Resolution: 4 states/2 bit, 0 offset
 Data Range: 0 to 3 Operational Range: same as data range
 Type: Status
 Supporting information:
 PGN 65132
 Note: Firmware captures all values [0x00-0x03].

Handling information:

Indicates that handling information is present. Information could include “no printer paper”, “no driver card”, etc.

00 – No handling information

01 – Handling information

10 – Error

11 – Not available

Data Length: 2 bits

Resolution: 4 states/2 bit, 0 offset

Data Range: 0 to 3 Operational Range: same as data range

Type: Status

Supporting information:

PGN 65132

Note: Firmware captures all values [0x00-0x03].

System event:

Indicates that a tachograph event has occurred. This may include power supply interruption, interruption of the speed sensor, incorrect data on the driver card, driving without a driver card, illegal removal of a driver card, insertion of a driver card during driving, and time adjustment.

00 – No tachograph event

01 – Tachograph event

10 – Error

11 – Not available

Data Length: 2 bits

Resolution: 4 states/2 bit, 0 offset

Data Range: 0 to 3 Operational Range: same as data range

Type: Status

Supporting information:

PGN 65132

Note: Firmware captures all values [0x00-0x03].

Tachograph vehicle speed:

Speed of the vehicle registered by the tachograph.

Data Length: 2 bytes

Resolution: 1/256 km/h per bit, 0 offset

Data Range: 0 to 250.996 km/h Operational Range: same as data range

Type: Measured

Supporting information:

PGN 65132

Note: Since FM FW sends this parameter as U16 (2 Bytes), value after floating point is discarded. So data limit becomes [0-250]. This parameter could be send as 1Byte IO (as [0-250] fits into 1B, but it is sent as 2B).

Firmware sends value which is already adjusted with bitgain.

Engine coolant temperature:

Temperature of liquid found in engine cooling system.

Data Length: 1 byte

Resolution: 1 deg C/bit, -40 deg C offset

Data Range: -40 to 210 deg C Operational Range: same as data range

Note: This parameter is to be interpreted as either a uint8_t or a int8_t, depending on the binary value. Values from 0x00 up to and including 0xD2 are of the type uint8_t (unsigned integer). Values from 0xD3 up to and including 0xFF are of the type int8_t (signed integer, two's complement). The value sent to the server has already been adjusted for the bitgain and offset.

Ambient air temperature:

Temperature of air surrounding vehicle.

Data Length: 2 bytes

Resolution: 0.03125 deg C/bit, -273 deg C offset

Data Range: -273 to 1735 deg C Operational Range: same as data range

Type: Measured

Supporting information:

PGN 65269

Note: Firmware sends value which is already adjusted with bitgain.

Driver 1/2 identification:

Used to obtain the driver identity.

Data Length: Variable ("*" delimited)

Resolution: ASCII, 0 offset

Data Range: 0 to 255 per byte Operational Range: same as data range

Type: Measured

Supporting information:

PGN 65131

Note: Firmware expects driver identification to fit into 24 bytes. According to captured driver ID length either 1/2/3 IO ID's will be sent to server (8 Bytes each). I.e. if driver ID length <= 8, only one IO ID (129) will be sent to server, if VIN length >9 and <= 16, then two IO ID's will be sent to server (129,130), and if driver ID length > 16 and <= 24 then three IO ID's will be sent to server (129,130,131).

Engine fuel rate:

Amount of fuel consumed by engine per unit of time.

Data Length: 2 bytes

Resolution: 0.05 L/h per bit, 0 offset

Data Range: 0 to 3,212.75 L/h Operational Range: same as data range

Type: Measured

Supporting information:

PGN 65266

Note: Since FW sends this parameter as U32, value after floating point is discarded. Data limit becomes [0-3,212]. Firmware sends value which is already adjusted with bitgain.

Engine instantaneous fuel economy:

Current fuel economy at current vehicle velocity.

Data Length: 2 bytes

Resolution: 1/512 km/L per bit, 0 offset

Data Range: 0 to 125.5 km/L Operational Range: same as data range

Type: Measured

Supporting information:

PGN 65266

Note: FW sends this parameter as U32, value after floating point is discarded. Data limit becomes [0-125]. This could have been 1 B IO element, but it is 4 B. Firmware sends value which is already adjusted with bitgain.

At least one PTO engaged:

Indicates that at least one PTO is engaged

00 No PTO drive is engaged

01 At least one PTO drive is engaged

10 Error

11 Not available

Note: This parameter should only be sent by the controller that has knowledge of all PTO drives on the vehicle (e.g, the FMS gateway). Individual PTO drive controllers should broadcast this parameter as “not available”.

Data Length: 2 bits

Resolution: 4 states/2 bit, 0 offset

Data Range: 0 to 3 Operational Range: same as data range

Type: Status

Supporting information:

PGN 64932

Note: Firmware captures all values [0x00-0x03].

High resolution engine total fuel used:

Note: Firmware sends value which is already adjusted with bitgain.

15.7 AutoCAN Configuration over SMS

15.7.1 SMS command format:

“<login><space><password><space>setparam<space><profile number><Element ID><space><Element format>”

if there is no login and password configured in FM configuration, 2 spaces must be used before command :

<space><space><command>.

Element format:

<SendDataToServer>,<HighLevel>,<LowLevel>,<DataAcquisitionType><averaging constant>

Element format values: <[0-7]>,<int32>,<int32>,<[0-5]>,<int32>

For example: <space><space>setparam 3347 2,70,50,3,10

Here we set FM6320 to make a high priority event once the FM6320 either reaches higher than 70km/h speed or starts going lower than 50km/h.

**If we wanted to configure FM6320 to make a panic event everytime brake pedal is either pushed or released, the SMS we would have to send is:

<space><space>setparam 3346 3,0,0,1,10 (here we skip HighLevel and LowLevel so we write 0)

15.7.2 AutoCAN element Id's

Table 55 AutoCAN element Id's

Category name	Element ID	Element name
Cruise Control/Vehicle Speed	346	Brake switch
	347	wheel based speed
	348	cruise control active
	349	clutch switch
	350	PTO state
Electronic Engine Controller #2	351	Accelerator pedal position 1 X
	352	Engine Percent Load At Current Speed X
Fuel Consumption	353	Engine total fuel used
Dash Display	354	fuel level 1 X
Electronic Engine Controller #1	355	Engine speed X
Vehicle Weight **	356-370	Axle location
		Tire location
		Axle weight
Engine Hours, Revolutions: HOURS	371	Engine total hours of Operation X
Vehicle Identification	372	vehicle identification number X
FMS Standard interface	373	SW-version supported X
	374	Diagnostics supported X
	375	Requests supported X
High Resolution Vehicle Distance	376	High resolution total vehicle distance X
Service Information	377	Service distance
Tachograph	378	Vehicle motion X
	379	driver 2 working state X
	380	driver 1 working state X
	381	Vehicle overspeed
	382	Driver 1 time rel. states
	383	Driver 2 time rel. states
	384	Driver 1 card X
	385	Driver 2 card X
	386	Direction indicator
	387	Tachograph performance X
	388	Handling information X
	389	System event X

Category name	Element ID	Element name
	390	Tachograph vehicle speed X
Engine Temperature 1	391	engine coolant temperature X
Ambient Conditions	392	Ambient Air Temperature X
Driver's Identification	393	Driver 1 ID
Driver's Identification	394	Driver 2 ID
Fuel Economy	395	Fuel rate
	396	Instantaneous Fuel Economy
PTO Drive Engagement	397	At least one PTO engaged
High Resolution Fuel Consumption (Liquid)	398	High resolution engine total fuel used

16 USING TACHOGRAPH

FM6320 device can read tachograph data. User can connect FM to vehicle unit tachograph device. Supported devices are: Siemens VDO Digital Tachograph – DTCO 1381 (release 1.3a, 1.4 or later) and Stoneridge Tachograph – SE5000 (release 7.1 or later)

16.1 Connecting to tachograph

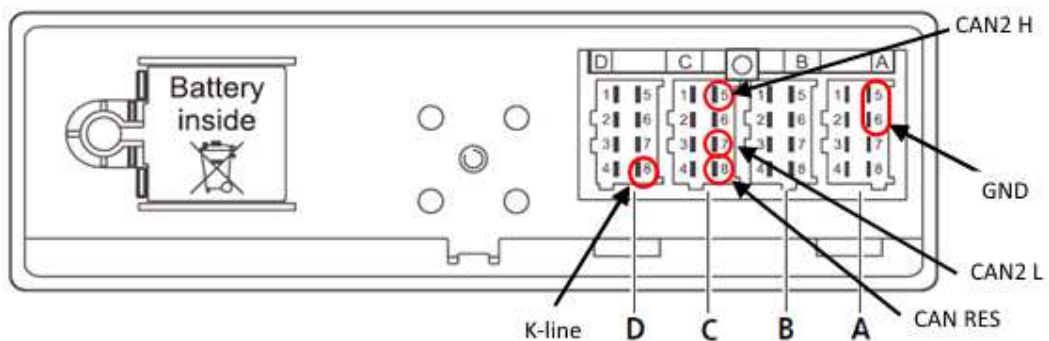

Figure 101 Tachograph connection

Connection to tachograph (Figure 101):

- Before connecting tachograph wires, it is required to measure CAN line resistance while tachograph is switched off:
 - Turn off the vehicle ignition;
 - Measure resistance between the C5 (CAN2 H) and C7 (CAN2 L) contacts;
 - If the multimeter shows ~120 Ohms, skip the next step;
 - If the multimeter shows kiloOhms resistance then it is needed to connect tachograph C8 (CAN-RES) and C7 (CAN2 L) contacts with wire and then perform further actions;
 - Re-measure the resistance of the line – it has to be ~120 Ohms.

- Connect CAN2 L and CAN2 H wires to tachograph (C5 (CAN2 H) and C7 (CAN2 L))
- All of the same level CAN-L and CAN-H wires must be interlaced with each other.



- CAN wires need to be installed as far as possible from GSM antenna.

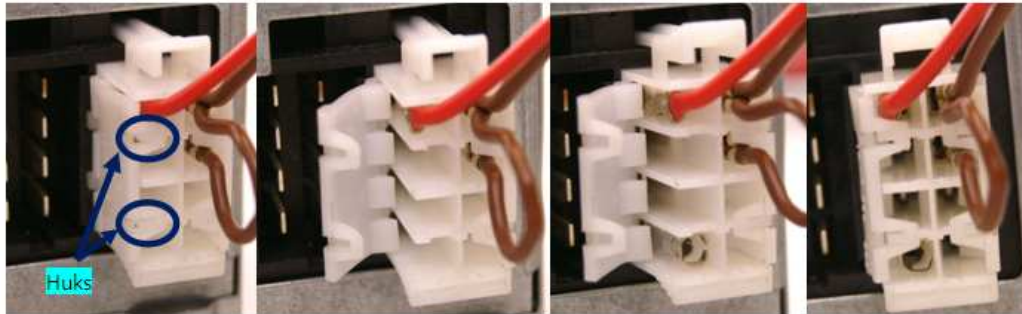

Figure 102 Adding contact on tachograph connector

- Tachograph D8 and adapter K-Line connectors connected directly.
- Tachograph mounted on vehicles does not have D8 contact. In order to add it, you have to undo the hooks and add the contacts (Figure 102). Contact code in Farnell system: 925596-1.
- Direct GND connection is required only if vehicle and tachograph grounds are not merged. (It can be checked using multimeter. Connection between different grounds should be 0 volts)

NOTE! Connecting to Stoneridge tachograph, for K-Line data, this configuration must take place:

1. Insert Company card in tachograph.
2. Configure tachograph in this way:

Menu->Settings->Parameters->D8 data format->SRE

Each described Vehicle Data element is packed to standard AVL packet and sent to server. Parameter values are sent depending on configuration element ID that are described in „K LINE ID“ column (IO parameter ID).

Vehicle data configuration window (Figure 103) can be opened by selecting “K Line” in the Configurator. There is the list which holds all elements, each one can be selected by ticking to its name.

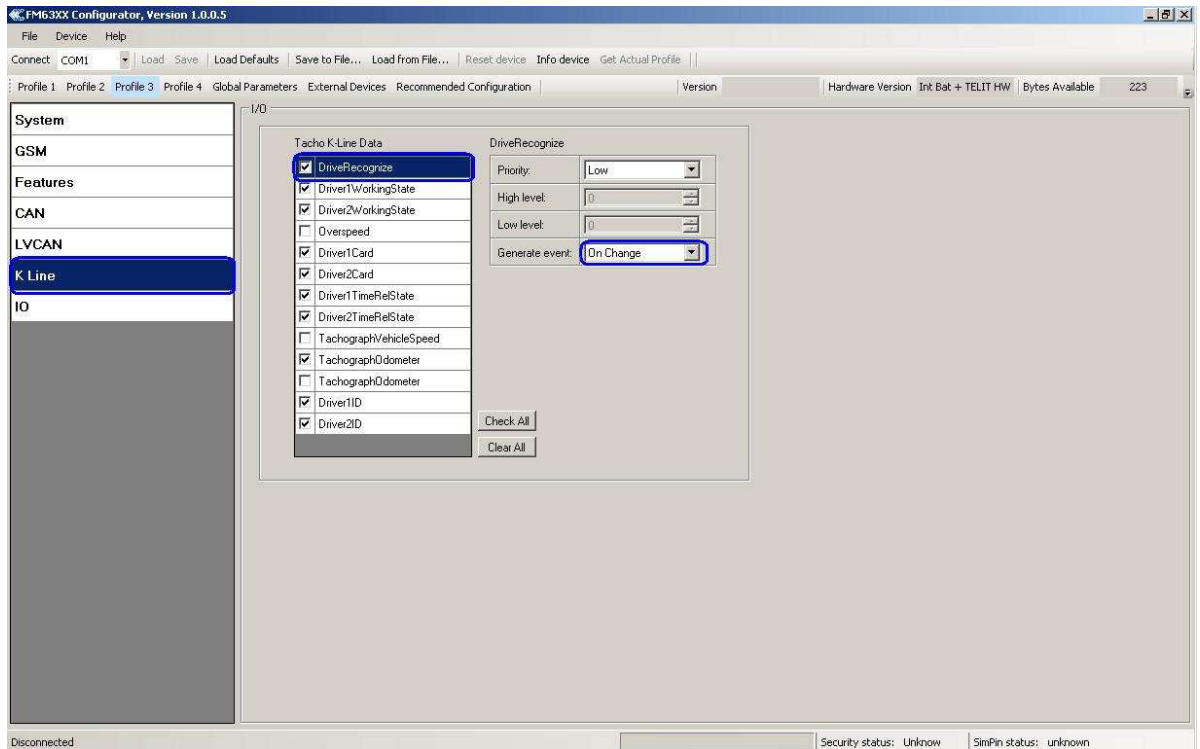

Figure 103 Vehicle data configuration window

Element configuration (Figure 104) shows selected element name (marked blue). By selecting other element name will change that way indicating which element is configuring. Priority: low and high. High, low level can be selected only by “Tachograph vehicle speed”, it depends on generate event selection which have “On change” and “Monitoring” modes, “Tachograph vehicle speed” has all (on exit, on enter, on both, hysteresis, monitoring, on change) modes.

To reduce GPRS traffic we recommend using default settings (most I/O elements should be generated “on change”)

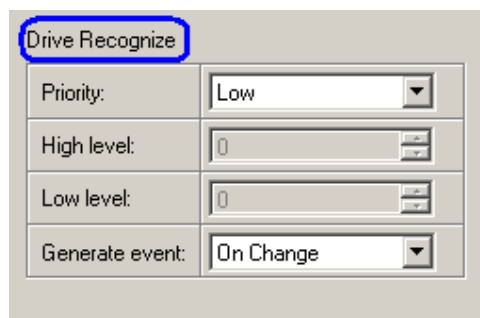

Figure 104 Vehicle data configuration window

Below configuration available byte size in record is shown, by selecting elements its decreasing and when reaches zero no more elements could not be selected.

Driver 1 ID and Driver 2 ID Tachograph data elements are packed to standard AVL packet and send to server dependent on configuration with element ID described in „K LINE ID“ column. Note that driver ID is 16 bytes long. For this reason it is split to 2 IO elements. On the server side it is required to merge those two IO elements to have full driver ID for whole 16 bytes.

It is also possible to configure Vehicle Data element using SMS or GPRS according to basic FM functionality, parameters described in table 32

16.2 Tacho WEB

WEB Solution for Tachograph files download. Teltonika Tacho WEB Solution is a big forward leap in remote tachograph data files download. Solution is easily manageable and does not require any complex software* installation. Everything is accessible via web page. Now you can download tachograph files from any place and from any PC with internet access.

*- **requires company card reader software installation on a single company PC**

Access and download tachograph files of your whole fleet from within a single, web browser-based interface. Compatible with browsers across all platforms, requires no installation or additional plug-ins

Once you create a schedule, selected tachograph files will be downloaded automatically. Data will be downloaded every defined period, for example once a week, once a month etc.

FM6320 device has a possibility to connect to WebDDD IP every 1 hour and check if there are any schedules for downloading DDD files. If FM6320 connects to WebDDD server, and there is a planned schedule but other device is already downloading and company card is in use, device keeps link with WebDDD server but still sends data to main server with AVL data. After successful download, device closes link with WebDDD and reconnects after 1 hour. Data is stored on secured server and can be accessed only by your authorized users. You don't need to worry that any file is lost and you have to download it from tachograph once again.

We support not only the standard DDD file extension, but also Spanish TGD and French V1B, C1B file formats. You simply set required one in Tacho Web user settings

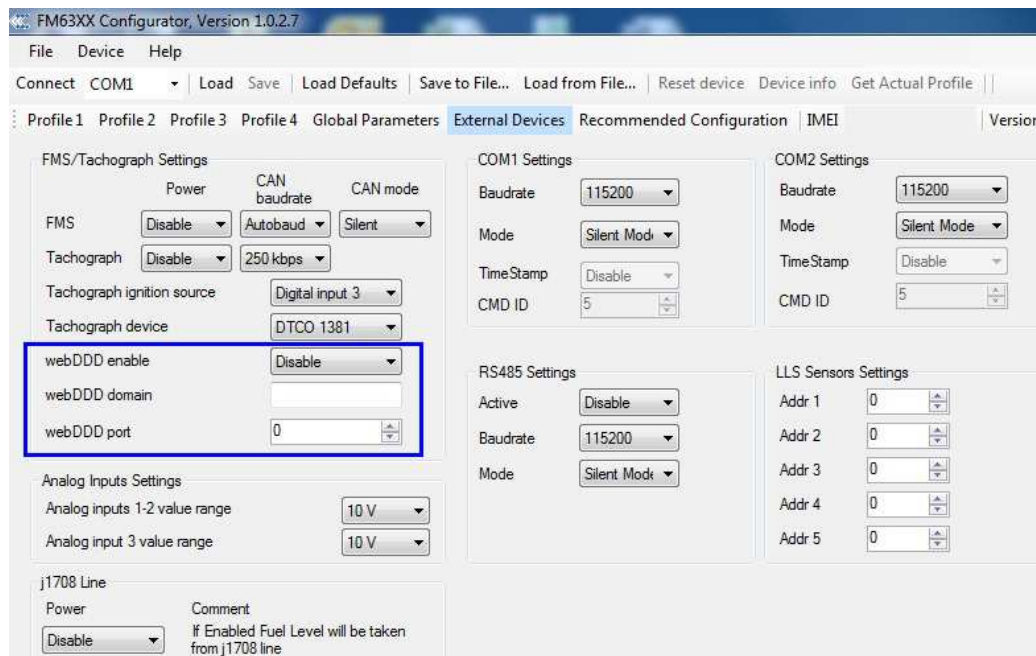

Figure 105 Connection to Web DDD

16.3 TACHOCHECK SMS

“tachocheck” sms message can be sent to device. It is used for getting status information. SMS response is of such structure:

CAN_2:[TRC],[ABCD], K-Line:[K]

[T] – Tachograph presence on bus:

- 0 – Tachograph doesn't respond on bus;
- 1 – Tachograph responds on bus.

[R] – Response to OpenRemoteSession validity check:

- 0 – Wrong or unknown response (failed to open RemoteSession);
- 1 – Tachograph responds positively (RemoteSession opened successfully).

[C] – Response to CloseLastAuthenticationSession validity check:

- 0 – Wrong or unknown response (failed to close last authentication session);
- 1 – Last authentication session closed successfully, device is ready to open new authentication session.

[K] – K-Line data presence on bus:

- 0 – K-Line data not present on bus;
- 1 – K-Line data present on bus.

[ABCD] – FMS data presence on bus:

- 0000 – FMS data not present on bus
- Non-zero – FMS data detected on bus.

FMS data value is shown in hexadecimal system and it is not important for the client.

17 RS485 INTERFACE

RS485 supports only Half Duplex communication. It means that at the same time you can't send/receive Data.

When activated RS485 driver chip draws constant 30mA current.

When Entering Sleep or Deep sleep Chip will be powered off too.

17.1 RS485 modes

In Configurator's windows select External devices window where is RS485 Settings as shown in Figure 106.

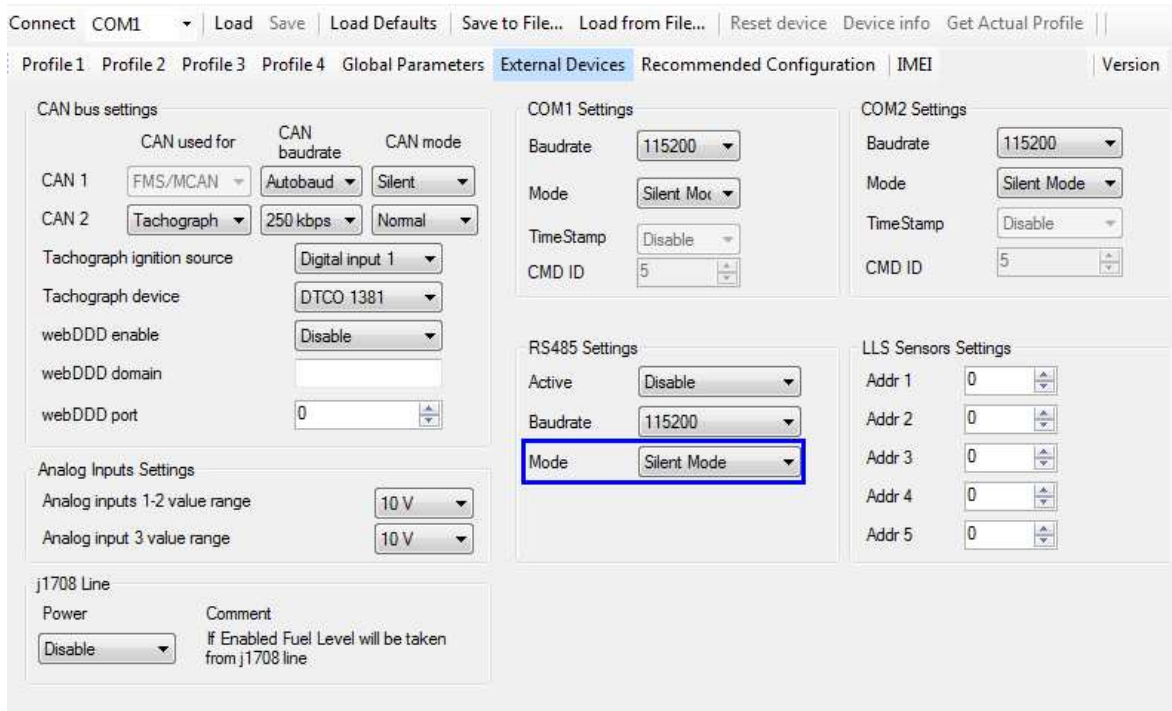

Figure 106 External Devices

The modes are described below are setting in the configuration window.

17.1.1 RS485 Receive (Silent) Mode

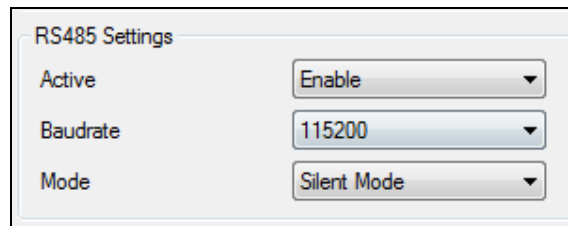

Figure 107 Silent Mode

RS485 Works in receive mode. Support debug and testing commands. When command is received answer is sent after that it back up to Receive mode.

17.1.2 RS485 Receive (TCP Link) Mode

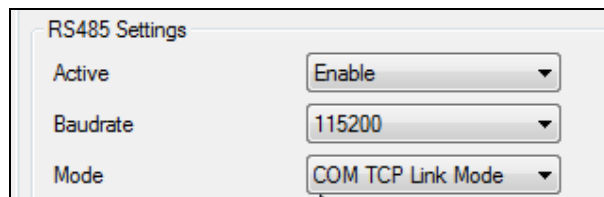
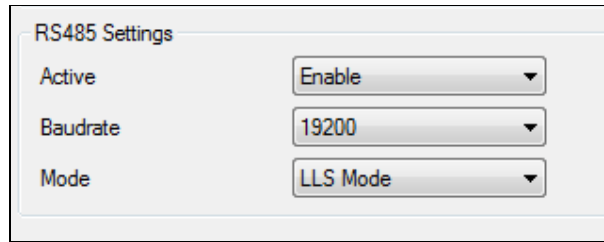

Figure 108 COM TCP Link Mode

RS485 works in receive mode. When data received from server RS485 is switched to transmit mode for 2 seconds.

17.1.3 RS485 Receive (LLS) Mode



The screenshot shows the 'RS485 Settings' window with three dropdown menus: 'Active' set to 'Enable', 'Baudrate' set to '19200', and 'Mode' set to 'LLS Mode'.

Figure 109 LLS Mode

The mode supports up to two LLS. Baud rate must be 19200. LLS have receiver id. Smaller ID will get ID: 201 and ID: 202. Bigger ID will get ID: 203 and ID: 204

17.1.4 RS485 Transmit (FM Log) Mode

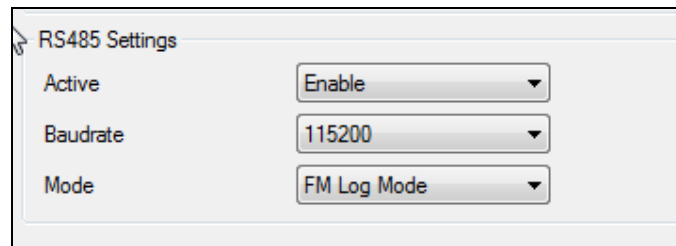

The screenshot shows the 'RS485 Settings' window with three dropdown menus: 'Active' set to 'Enable', 'Baudrate' set to '115200', and 'Mode' set to 'FM Log Mode'.

Figure 110 FM Log Mode

RS485 works in transmit mode, it prints FM log. It won't respond to commands

17.1.5 RS485 Transmit (GPS Nmea) Mode

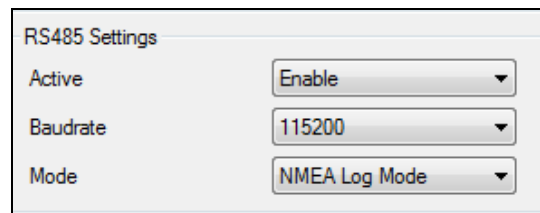

The screenshot shows the 'RS485 Settings' window with three dropdown menus: 'Active' set to 'Enable', 'Baudrate' set to '115200', and 'Mode' set to 'NMEA Log Mode'.

Figure 111 NMEA Log Mode

RS485 works in transmit mode, it prints NEMA. It won't respond to commands

17.1.6 RS485 Self-Test Mode

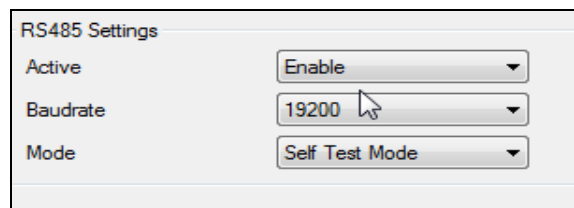

The screenshot shows the 'RS485 Settings' window with three dropdown menus: 'Active' set to 'Enable', 'Baudrate' set to '19200', and 'Mode' set to 'Self Test Mode'. A mouse cursor is visible over the '19200' dropdown.

Figure 112 Self Test Mode

Both transmitter and receiver are active. Transmitted info will be echoed back.

17.2 RS485 interface

Port connection diagram are shown on the Figure 113:

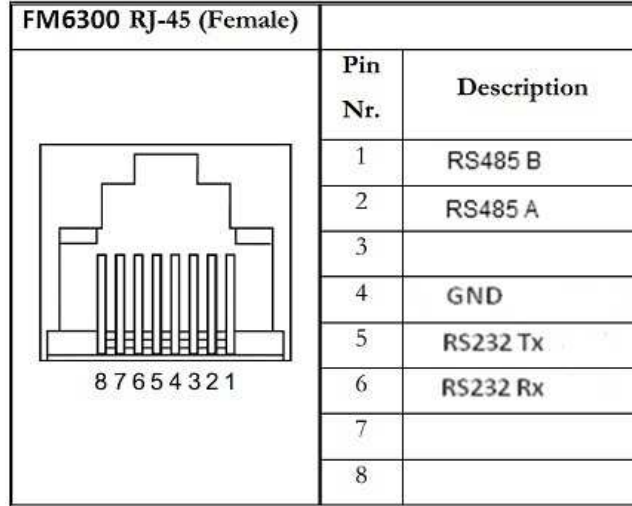

Figure 113 Port 1 connection diagram

Pins numbers 1 and 2 are intended to RS485 interface connection

18 RFID

Radio-frequency identification (RFID) is the use of a wireless non-contact system that uses radio-frequency electromagnetic fields to transfer data from a tag attached to an object, for the purposes of automatic identification and tracking. FM6320 can be configured in a way to use with an RFID reader. When an RFID of some sorts (typically a plastic card with a magnetic line) is used with an RFID reader which is connected to FM6320, the device creates a record with the data that the RFID reader has read and can be sent to a server with all other information. RFID ID is activated like an I/O parameter (Figure 114).

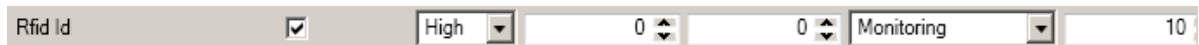

Figure 114 RFID I/O parameter

To set up FM6320 so it can be connected to an RFID reader, Global parameters have to be set up. Go to external devices and set up COM2 settings to RFID Mode or RFID MF7 Mode (the used mode depends on the mode that the RFID reader works). See Figure 115. The Baudrates for each mode are:

RFID Mode – 57600

RFID MF7 Mode – 9600

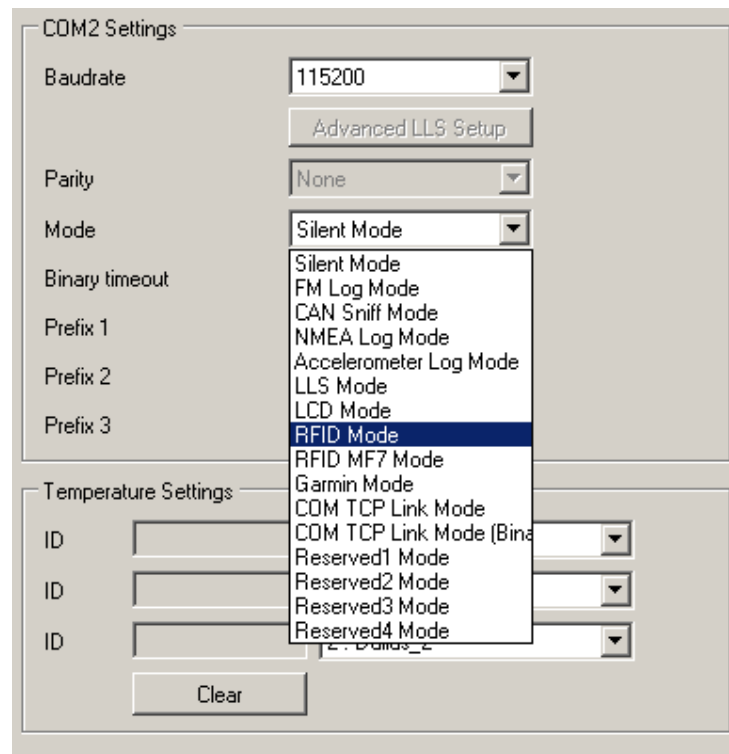

Figure 115 RFID Global parameter settings

The difference between RFID Mode and RFID MF7 Mode is that in RFID Mode FM6320 understands RFID messages that are in hexadecimal format and RFID MF7 Mode understands messages that are in decimal format. For example:

RFID Mode message – “\$aa\$02\$03\$04\$17\$89\$00\$01”

RFID MF7 Mode message – “1213141519”

The chosen mode has to correspond to the RFID reader’s mode. What type of RFID is sent to FM6320 depends on the reader.

For more information about RFID ID’s and devices, please contact to your local sales representative.

19 GARMIN

Garmin provides a Fleet Management Interface Tool Kit which connected to FM6320 enables the driver to have a "screen" in their vehicle for real-time navigation, messaging, and job dispatch capabilities to help them be more efficient.

FM6320 and Garmin operational scheme is shown in Figure 116 below:



Figure 116 FM6320+Garmin operational scheme

19.1 Supported Garmin FMI Protocols

The following is a list of protocols supported and the corresponding feature/benefit. FM6320 can fully support Fleet Management Interface (FMI) versions up to 2.1. Other or higher versions may be supported, but Teltonika is not responsible for the changes made by Garmin, which may affect the work of FM6320 and Garmin products. For more information about Garmin products and FMI versions, please go to <http://www8.garmin.com/solutions/pnd/supportedproducts.jsp>. Notice that some Garmin products use different connection cables than others.

19.1.1 Standard protocols

Text Message Protocol:

- Allows text messages sent to device to be displayed in "inbox" on unit.
- Garmin can provide confirmation that message was read.
- Garmin can also provide a yes/no box below the text of the message to enable a simple quick response.
- Messages can be up to 199 characters in length.
- Messages can also be generated from device and sent to dispatch/office.
- Messages received will be notified to driver through a pop-up alert on Garmin screen.
- Garmin provides a "virtual keyboard" on device through a touch-screen format for all text communication.

Stop (Destination) Protocol:

- Garmin can display a list of Stops/Jobs reported to the device in a separate icon called "My Stops".
- Driver has ability to navigate directly to Stop from list.
- Garmin can provide status on current Stop in progress.
- Is driver stopped at location?
- How far has Driver progressed through the list of Stops?
- Garmin can also provide confirmation that driver has received a particular Stop, read the details, or deleted it from list.
- Can provide confirmation that a Stop has been completed.

Estimated Time of Arrival Protocol:

- Dispatcher/office can request the ETA of the current stop/job in progress.
- Garmin will notify the actual time of arrival as well as distance remaining to stop.

Auto-Arrival at Stop Protocol:

- This feature is used to tell the Garmin PND to automatically detect that it has arrived at a Stop and then to prompt the driver if they would like to mark the Stop as done and begin navigating to next Stop on the list.
- Auto-arrival can be determined by how long the unit is stopped close to the destination (in the event driver has to park and walk) or by how close the unit needs to be to the destination before the Auto-arrival feature is activated.

Data Deletion Protocol:

- Dispatch/office has the ability to wipe clean the data on the Garmin PND.
- Clean up messages in inbox/remove stops.

19.1.2 Enhanced protocols

Canned Responses/Messages:

- Fleet managers can communicate by sending up to 200 "canned" responses from server to be stored directly on Garmin devices.
- Up to 50 of these canned responses can be utilized for any given scenarios.
- Drivers can store up to 120 canned messages, eliminating the need to type while driving.

Status Protocol:

- Up-to-the-minute communications that allow drivers to automatically send status updates.
- Driver's units can store up to sixteen status indicators such as start/stop shift, on/off break, etc.

19.2 Supported features on TavI client application

TavI client application lets user to use the following features of GARMIN FMI:

1. Text messaging.
2. Destination message.
3. ETA request.

19.3 Text messaging

Text messaging feature lets user to communicate with driver (user that uses Garmin device) by sending text messages via GPRS.

19.4 Destination message

Destination message is used to inform a driver of a new destination. When Garmin device receives a destination message from server it displays it as "Stop" to the driver and also gives the driver ability to start navigating to the "Stop" location. New destination in TavI client is represented as Geozone so new Geozone (as destination) has to be created first.

19.5 ETA request message

ETA (Estimated Time of Arrival) request message is used when user wants to know expected arrival time to currently active destination and distance (in meters) from current object location to currently active destination.

19.6 Connection and pinout

FM6300 RJ-45 (Female)	
Pin Nr.	Description
1	RS485 B
2	RS485 A
3	
4	GND
5	RS232 Tx
6	RS232 Rx
7	
8	

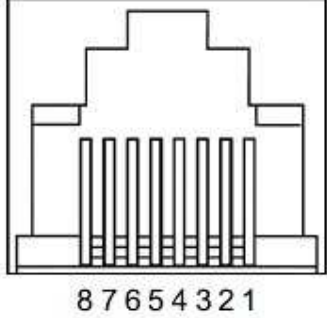

Figure 117 RJ45 Pinouts

In order to connect Garmin PND to FM6320, Garmin mode has to be set in Global parameter settings (Figure 118). Simply choose Garmin mode in COM2 settings mode, but you cannot activate Garmin mode in both ports at the same time.

FM6320 is able to filter out some of Garmin FMI packets that are not used in some applications (including Tavl system) and generates additional data transfer at the same time increasing bills of GSM services. In order to enable Garmin FMI Ping Packet Filtering set this feature from Global parameters at the bottom – enable Garmin Ping setting

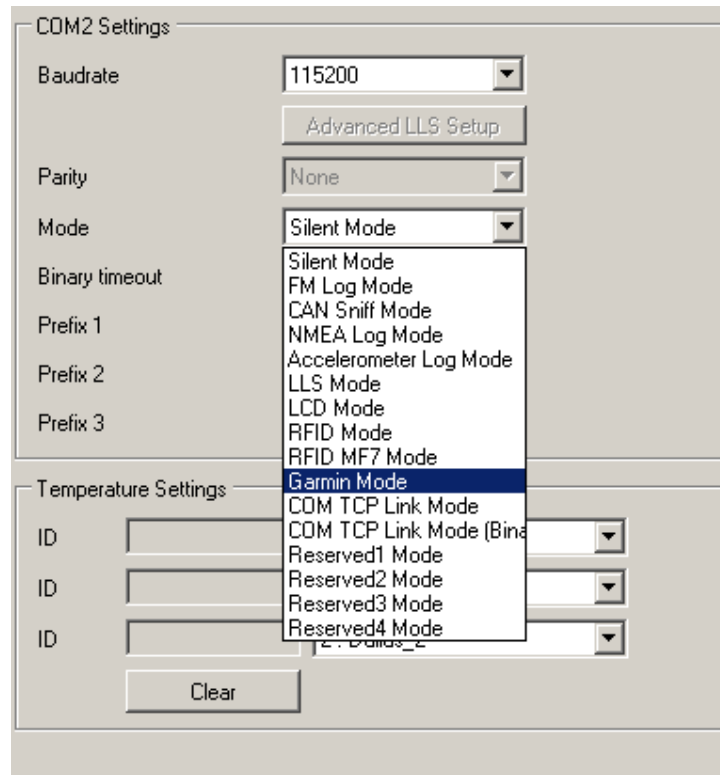

Figure 118
Configuration of Garmin in Global parameter settings



NOTE: Garmin FMI protocols are supported only in TCP data transfer mode.



Garmin Fleet management Interface documentation can be downloaded from Official Garmin web page: http://developer.garmin.com/download/FMI_v2-5.zip.

Software version updates: <http://www8.garmin.com/support/download.jsp>.

For more information about Garmin PND device connectivity to FM6320 and additional information, please contact to your local sales representative.

20 LLS SENSOR

LLS sensor series liquid level sensors are solid-state capacitive devices with no moving parts. The sensors use capacitive technology to produce accurate liquid level measurements of standard factory grade DIESEL OIL and PURE GASOLINE (BENZINE) carbon fuels.

The LLS sensor liquid level sensors are strictly prohibited to use in any liquids which are not the factory grade carbon fuels or contain: BIOFUEL, METHANOL, ETHANOL, UREA and similar aggressive components in pure form or as additives for factory grade carbon fuels for use in INTERNAL COMBUSTION ENGINES. Operating media – Diesel fuel (oil), pure gasoline (benzene).



IMPORTANT!

The power supply is 10-50 VDC stabilized. The wrong polarity (-) or (+) connection of power supply will damage or destroy the device. Prohibited for test or use in water and any other liquids, which are not factory grade carbon fuels. Fit the plastic insulation cap on the end of the central rod after installation accordingly to installation guide. To be installed, calibrated, tested only by qualified authorized person (installer, technician, mechatronic).

20.1 Specifications

Supply voltage, DC V	10...50*
Current consumption, mA (for 12/24 V)	25/50
Operation temperature, Celsius degrees	-40...+85
Working mode	continuous
Weight, kg	< 2.0
Working pressure	atmospheric

20.2 Hardware

- Operation principle: capacitive.
- Output: RS-232.
- Standard probe lengths: 700, 1000, 1500 mm.
- Optocoupler isolation on both power and signal circuits.

20.3 Connecting LLS to FM6320

In order to use LLS fuel counter the newest firmware version is needed which can be obtained from Teltonika or a representative. Firmware is updated over GPRS or using cable update method (see chapter 4 for more information).

The LLS fuel sensor must be connected to the FM6320 device. The FM6320-LLS fuel sensor schemes are shown below Figure 119.

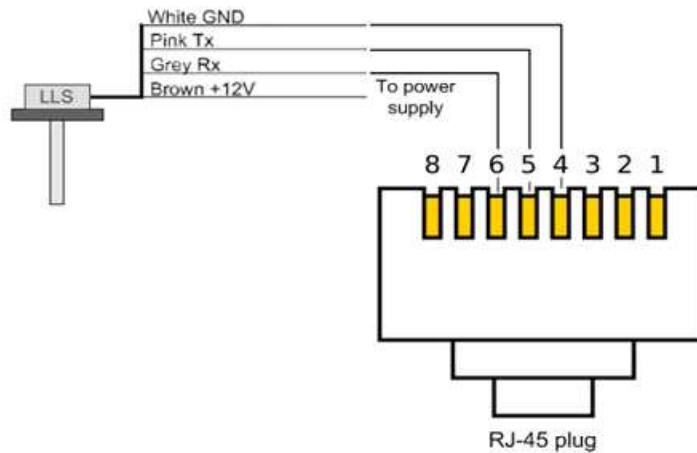

Figure 119
FM6320-LLS fuel sensor connection scheme RJ-45 male plug

*Teltonika is not responsible for any changes made by the manufacturer, which is not declared in fuel level sensor documentation.

Then FM6320 must be configured. Both fuel level and fuel temperature has to be set up by configurator's I/O menu (see Figure 120):

LLS #1 Fuel	<input checked="" type="checkbox"/>	Low	0	0	Monitoring	10
LLS #1 Temperature	<input checked="" type="checkbox"/>	Low	0	0	Monitoring	10
LLS #2 Fuel	<input checked="" type="checkbox"/>	Low	0	0	Monitoring	10
LLS #2 Temperature	<input checked="" type="checkbox"/>	Low	0	0	Monitoring	10
LLS #3 Fuel	<input checked="" type="checkbox"/>	Low	0	0	Monitoring	10
LLS #3 Temperature	<input checked="" type="checkbox"/>	Low	0	0	Monitoring	10
LLS #4 Fuel	<input checked="" type="checkbox"/>	Low	0	0	Monitoring	10
LLS #4 Temperature	<input checked="" type="checkbox"/>	Low	0	0	Monitoring	10
LLS #5 Fuel	<input checked="" type="checkbox"/>	Low	0	0	Monitoring	10
LLS #5 Temperature	<input checked="" type="checkbox"/>	Low	0	0	Monitoring	10

Figure 120 FM6320 I/O Configuration

21 MVC300 CAMERA

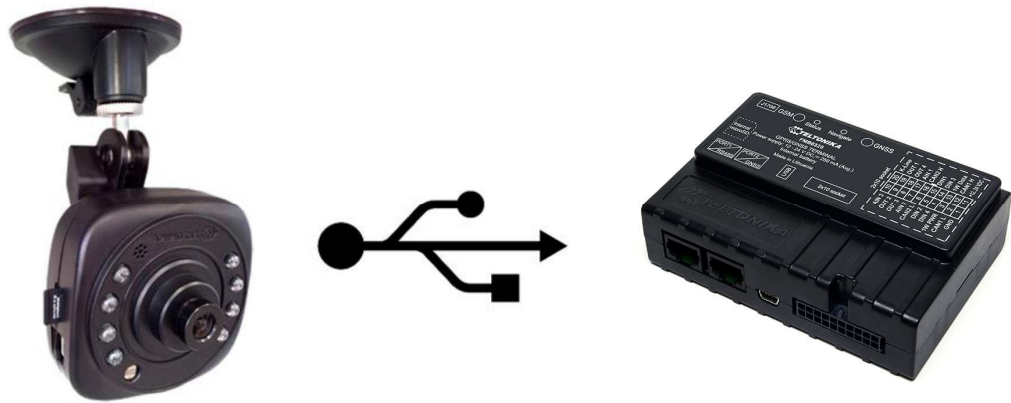

Figure 121 FM6320 and MVC300 Solution for Real time pictures

21.1 Introduction

This chapter contains information about FM6320 device and MVC300 camera interconnection, integration and use. Before using this solution, you should have some basic understanding of the following:

- FM6320 operational principals;
- MVC300 operational principals;

21.2 Startup and Configuration

To get FM6320 ready for downloading pictures from MVC300 camera, you need to use base fw 00.01.09 or newer. In configuration, you must set server IP, port and APN of SIM card, these parameters are in first configurator page as shown in Figure 122 Simple Configuration:

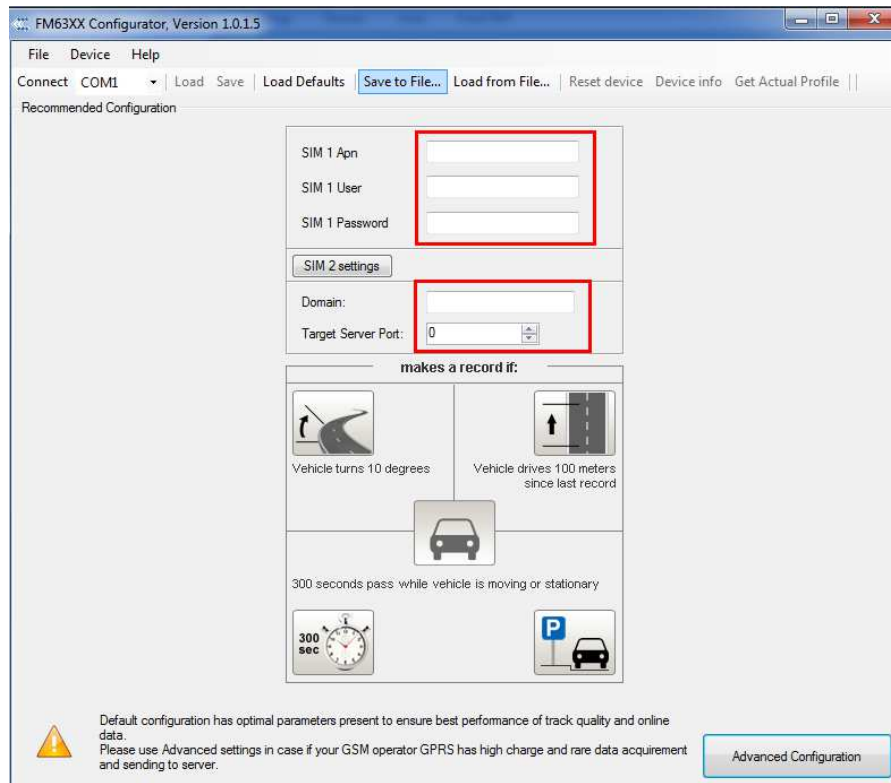

Figure 122 Simple Configuration

To set up picture creation configuration, select Advanced Configuration, which is in lower right corner of configuration. Select Camera page

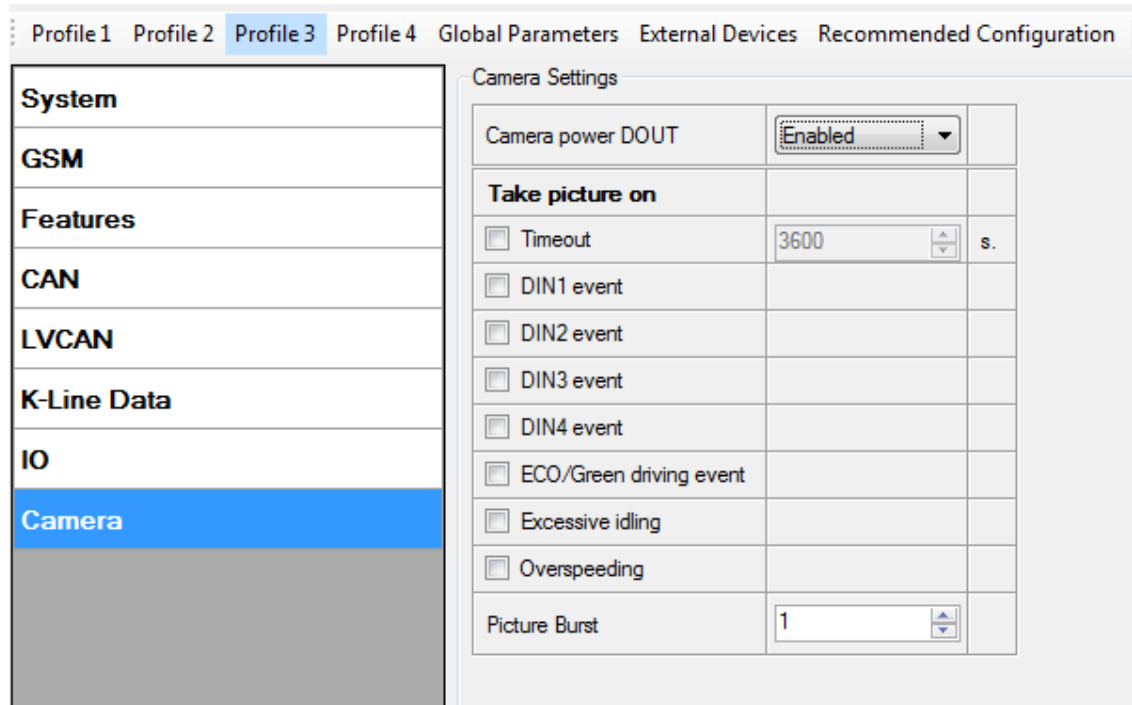

Figure 123 Camera Configuration

21.2.1 Camera parameters in FM6320:

Camera power DOUT – function which is used to enable Camera functionality and select defined DOUT for restarting physically MVC300 camera.

Timeout parameter – parameter enables periodical photo sending. Default parameter 3600 seconds.

DIN events – picture will be made, when selected DIN event will occur.

Eco/Green driving events – picture will be created, when one of eco/green driving event occurred (harsh acceleration, harsh cornering or harsh braking)

Excessive idling – picture will be made, when excessive idling event will be occurred (activated) and when event will be deactivated.

Overspeeding – picture will be made, when overspeeding event will be activated (entering) and when event will be deactivated (exiting)

Picture burst – parameter defines how much pictures will be made after configured picture event occurs. Between pictures will be 3 sec time gap.

21.2.2 Camera parameters in MVC300:

To prepare MVC300 connection with FM6320, following steps must be done: MVC300 must have firmware version - MVC330_WebUI_FW_MVC330_F_00.01.599 or newer. Main thing is, that firmware must be with F marking, which means, FM device support. To check what firmware version your MVC300 have, you need to go - <http://192.168.1.10>, it is camera's WEB UI.

In WEB UI select – Maintenance page, there you will find box of firmware version. If your firmware is not with F marking, you must update firmware. If you don't have compatible firmware, please contact our Teltonika sales manager.

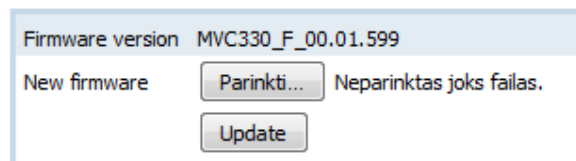

Figure 124 Firmware Update

After selecting firmware, press upgrade button as shown in Figure 124 Firmware Update.

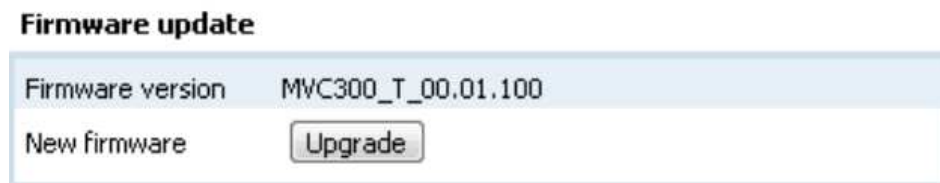

Figure 125 Firmware Upgrade

After successful update, you will be redirected to main WEB UI window, if some error occurs, please clear your browser cache or open browser in new incognito window.

In WEB UI of MVC300 camera you can select resolution of picture which will be made when used in FM6320 and MVC300 solution.

In WEB UI select page – Video settings, in streams resolution, you can select between 320x190 and 720x480 resolution, as shown in **Error! Reference source not found.**

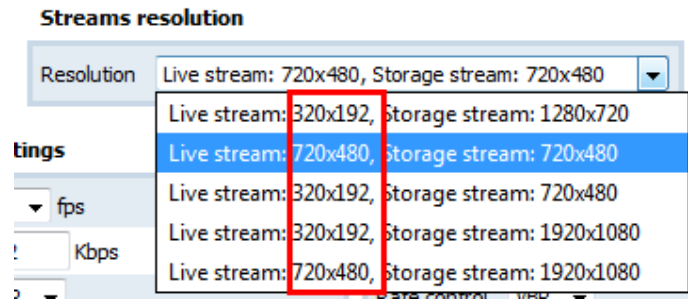

Figure 126 Resolution Selection

After successfully installing right firmware version and selecting resolution – MVC300 is ready to use with FM6320 device

21.3 FM6320 and MVC300 connection

To prepare solution you will need:

- FM6320 with 00.01.09 FW or newer version;
- MVC300 camera with original power cable or special cable which can be order severalty, for more info please contact Teltonika sales manager. Special cable have possibility to restart MVC300 camera and make solution more stable;
- Standard mini USB cable and USB plug to mini USB cable.

Connection is very simple, connect power wires of FM6320, connect MVC300 to power plug and connect camera with FM6320 over two USB cables. After connection is done, solution is ready to use.

22 GPRS COMMANDS

It is possible to send commands to FM6320 using GPRS. When FM6320 sends records periodically to a server, a message could be sent from the server and FM6320 will reply to it. FM6320 has to be connected to the server in order to receive commands.

Table 56 GPRS Commands

Command	Description
#GET DATAORDER	Get info about records sorting parameter
#GET RECTO	Get info about records refresh timeout parameter
#GET VERSION	Receive firmware version
#GET NETWORK	Get GSM operator to which device is connected
#GET IMSI	Get IMSI of the device
#GET OUT	Get DOUT values

Command	Description
#DO REPORT	Save a record
#GET ROAMINGX=Y	Get operator from the list of a certain profile, X – profile, Y – operator number in a list
#GET REMIPX	Get IP and port number from the configuration of a certain profile, X – profile
#GET AUPX	Get APN, user login and password from the configuration of a certain profile, X – SIMSLOT
#GET REPRTX	Get MinPeriod from the configuration of a certain profile, X – profile
#GET REPDISTX	Get MinDistance from the configuration of a certain profile, X – profile
#GET REPANGX	Get MinAngle from the configuration of a certain profile, X – profile
#GET SENDPERIODX	Get SendPeriod from the configuration of a certain profile, X – profile
#GET REPMRX	Get MinRecords from the configuration of a certain profile, X – profile
#GET IBTN=X	Get iButton value from the configuration of a certain profile, X – number on the list
#GET EXTERR	Get extended errors value

There is also a possibility to send the same messages as in SMS command list (chapter 13). The device sends a response to every command received.

Table 57 SMS Commands

Command	Description
getstatus	Modem Status information
getweektime	Current device time, Day of Week and amount of minutes passed since start of week
getops	List of currently used and available GSM operators
readops#	Emergency gsm operator readout from active profile # - 1,2,3 1 – operators [1-20] 2 – operators [21-40] 3 – operators [41-50]
getnmeainfo	Nmea error debug sms
getcfgtime	Date and Time of last successful configuration
getgps	Current GPS data and time
loadprofile#	Load specified profile into RAM Engine Profile. # - number of profile to load
cpureset	Reset CPU
resetallprof	Reset all FLASH profiles to default profile
getver	Device / Modem / Code version information
getinfo	Device runtime system information
deleterecords	Delete all records saved on FLASH
getio	Readout digital inputs and outputs, analog inputs
banlist	Banlist information
crashlog	Crash log information
delete_all_sms	Delete all read SMS

Command	Description
braminfo	BatRam info
getgnss	Current GNSS information
resetlimits	Resets data counters
sn x [x=0;1]	Enable/disable static navigation
radio #	Readout input value according entered ID, # - ID value
setdigout XXXX Y1 Y2 Y3 Y4	Set digital outputs 0 – OFF, 1 – ON Y1 – timeout for DO1 Y2 – timeout for DO2 Y3 – timeout for DO3 Y4 – timeout for DO4
getparam #	Readout parameter value according entered ID. # - ID value.
setparam # #	Set parameter value according entered ID and Value. 1.# - ID value. 2.# - New Parameter Value
flush #,#,#,#,#,#,#	Initiates all data sending to specified target server 1.# - IMEI 2.# - APN 3.# - LOGIN 4.# - PASS 5.# - IP 6.# - PORT 7.# - MODE (0-TCP/1-UDP)



ATTENTION!

In order to send these commands, they have to be converted to special format. How to convert to this format and for additional information on how to send GPRS commands, please contact to your local sales representative.

23 DEBUG MODE

FM6320 is able to transmit its current state when connected to PC using PORT1/2 and USB cable. To debug FM6320 with USB cable, in terminal you should set high level to DTR pin. It is used to detect errors and provide information to possible solutions when operating as unexpected. Contact our sales manager to get Terminal. After launching it choose baud rate 115200 and hardware control – none. Click on 'Start Log' button and save a new file. Then click 'Connect' to start receiving messages from FM6320 (see Figure 127)

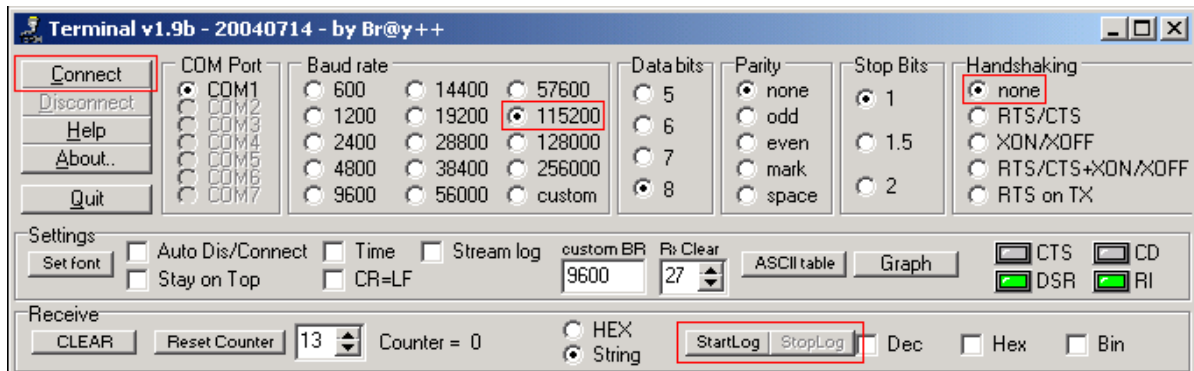

Figure 127 Terminal Window

To debug NMEA GPS data, connect PORT3 cable to COM2 port, or connect PORT2 cable and enable nmea log mode, or via USB cable activating nmea log mode by sending `.log_nmea:1` command in terminal.

24 FM6320 REMOTE LOG

LOG BOOK

Two types of log book: online, offline.

Online log book is initiated using command `log2srv` and set right configuration. Device establish GPRS connection and activates link to server, log started to stream to server until set time is elapsed. To stop streaming immediately `log2srvstop` is used.

Offline log book is initiated using command `log2srv` and set right configuration. Device start log writing to flash, this action is performed until set time is elapsed.

To read offline log `log2srvstart` command is used. It sends log to earlier preconfigured server (`log2srv`). Offline log sending also can be terminated using `log2srvstop` command.

COMMANDS

- `"SMSlogin<space>SMSpassword<space>log2srv<space><enable>,<mode>,<APN>,<username>,<password>,<IP>,<port>,<TMO>,<Log mode>"`
 - `<enable>` - enable (1), disable(0);
 - `<mode>` -
 - `silent (0)` – connect to server and send "Hello" message (all "Terminal" commands can be used)
 - `echo_time (1)` – send log with lines, where is TIME "for example: - [2013.1.23 14:49:45]-[PERIODIC.BAN.LIST.INFO]:"
 - `echo (2)` – send log with lines where is no TIME "for example: [DIN1.FUNC]->Waiting for DIN1 to be ON"
 - `echo/echo_time (3)` – send full log
 - `modem (4)` – send just AT commands
 - `NMEA (5)` – send NMEA log.
 - `<APN>` - operators' APN which will be used for data sending;

- <username> - operators' username;
 - <password> - operators' password;
 - <IP> - servers' IP address to which offline/online log will be send after request ("log2srvstart");
 - <port> - servers' port;
 - <TMO> - indicates time of offline log writing to flash or online log sending to server;
 - <Log mode> - configuration for online mode (0), configuration for offline mode (1);
- "SMSlogin<space>SMSpassword<space>log2srvstart"
 - "SMSlogin<space>SMSpassword<space>log2srvstop"

Example: opa opa log2srv 1,3,banga,,,212.47.99.62,7092,300,0



Note: Up to 5 minutes delay could appear if wrong "log2srv" commands settings will be sent, during that time no SMS or GPRS command could be received. SMS will be hanging, after timeout, hanging SMS's will be proceeded.

DOWNLOADING LOG USING "HERCULES" program

STEP 1:

- set special chars – ASCII
- Write down your PORT in the *Port* field and click on *listen* (screen below)

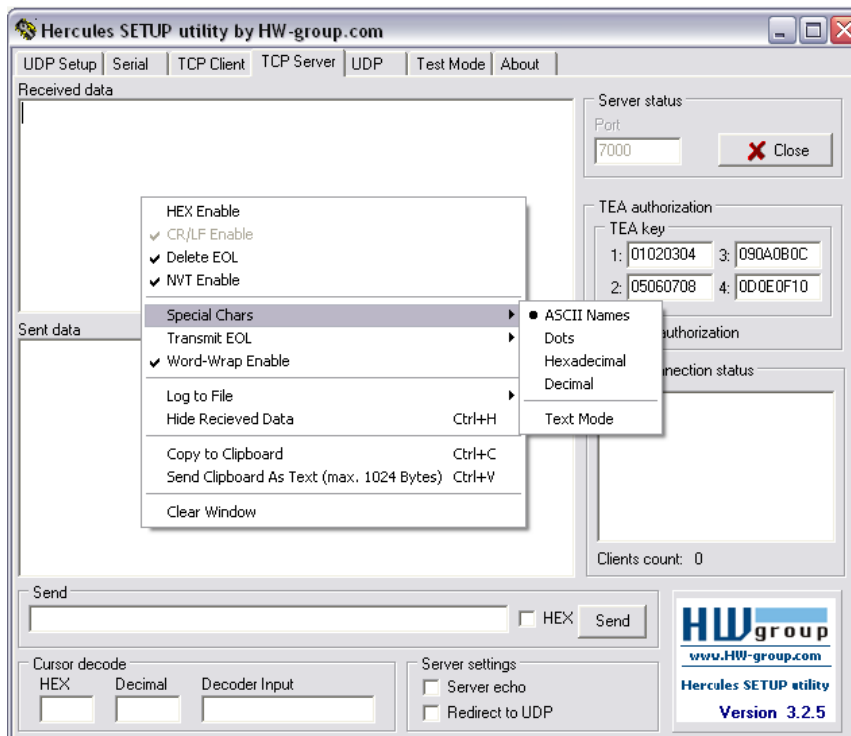

Figure 128

STEP 2

- click *Log to File*, then choose the directory where you want to log it in, give your log a name and click *open*
- Right click again and click on *Log Enable* OR just use *Ctrl + L* combination instead.

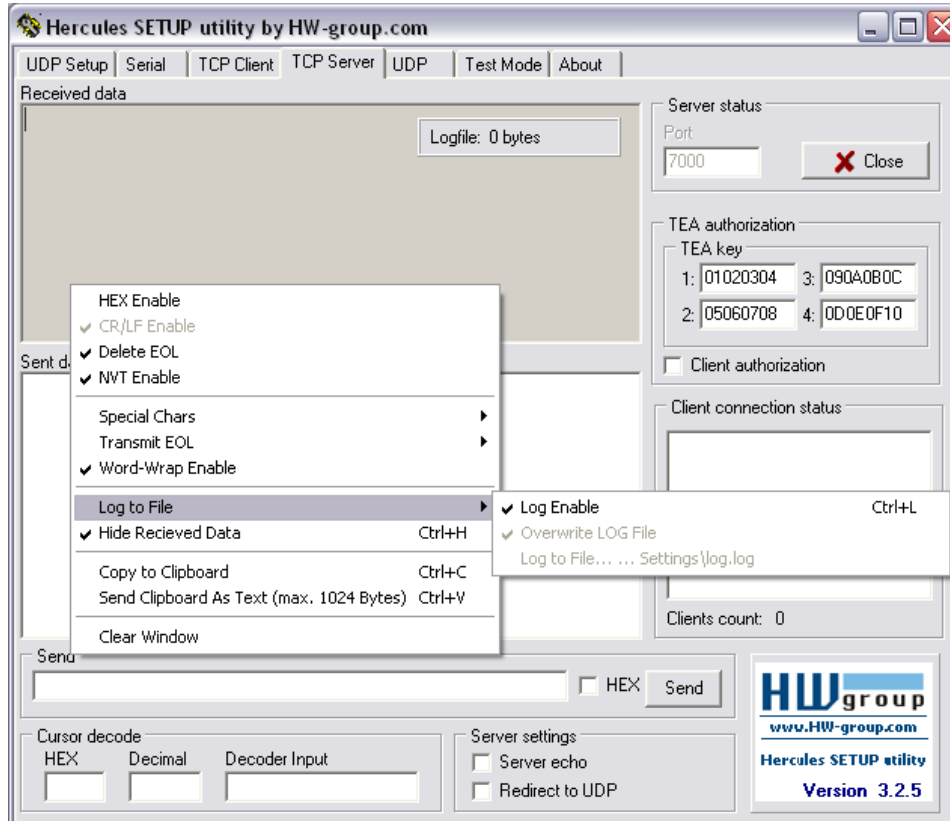

Figure 129

STEP 3

- Sending "Terminal's" commands through Hercules server

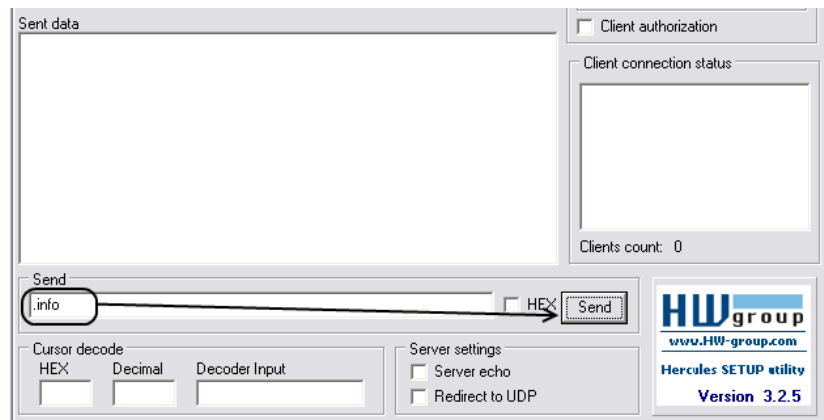

Figure 130

MOUNTING RECOMMENDATIONS

24.1 Connecting Wires

- Wires should be connected while module is not plugged in.
- Wires should be fastened to the other wires or non-moving parts. Try to avoid heat emitting and moving objects near the wires.
- The connections should not be seen very clearly. If factory isolation was removed while connecting wires, it should be applied again.
- If the wires are placed in the exterior or in places where they can be damaged or exposed to heat, humidity, dirt, etc., additional isolation should be applied.
- Wires cannot be connected to the board computers or control units.

24.2 Connecting Power Source

- Be sure that after the car computer falls asleep, power is still available on chosen wire. Depending on car, this may happen in 5 to 30 minutes period.
- When module is connected, be sure to measure voltage again if it did not decrease.
- It is recommended to connect to the main power cable in the fuse box.
- Use 3A, 125V external fuse.

24.3 Connecting Ignition Wire

- Be sure to check if it is a real ignition wire – power does not disappear while starting the engine.
- Check if this is not an ACC wire (when key is in the first position, most electronics of the vehicle are available).
- Check if power is still available when you turn off any of vehicles devices.
- Ignition is connected to the ignition relay output. As alternative, any other relay, which has power output, when ignition is on, may be chosen.

24.4 Connecting Ground Wire

- Ground wire is connected to the vehicle frame or metal parts that are fixed to the frame.
- If the wire is fixed with the bolt, the loop must be connected to the end of the wire.
- For better contact scrub paint from the place where loop is connected.



PAY ATTENTION! Connecting the power supply must be carried out in a very low impedance point on-board vehicle network. These points in the car are the battery terminals. Therefore, we recommend connecting the power of FM6320 (wire GND and POWER) directly to the battery terminals. Another valid option is to connect the wires to the main POWER cable inside the fuse box (if there is none, then to the power supply where the fuses of vehicle's computer are), wire GND must be connected in a special point, designed to connect GND vehicle computer. Connecting the GND at an arbitrary point to the mass of the car is unacceptable, as static and dynamic potentials on the line GND will be unpredictable, which can lead to unstable FMB630 and even its failure.

24.5 Connecting Antennas

- When placing antennas avoid easily reached places.
- Avoid GNSS antenna placement under metal surfaces.
- Avoid placing FM6320 device near car radio, speakers or alarm systems.
- GNSS antenna must be placed so its state is as horizontal as possible (if antenna is leant more than 30 degrees, it is considered incorrect mounting).
- GNSS antenna cable cannot be bent more than 80 degrees.
- GNSS antenna must be placed sticker facing down

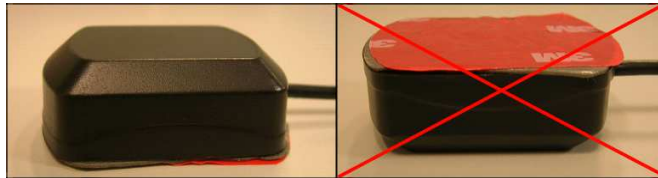

Figure 131

It is recommended to place GNSS antenna behind dashboard as close to the window as possible. A good example of GNSS antenna placement is displayed in a picture below (area colored green).

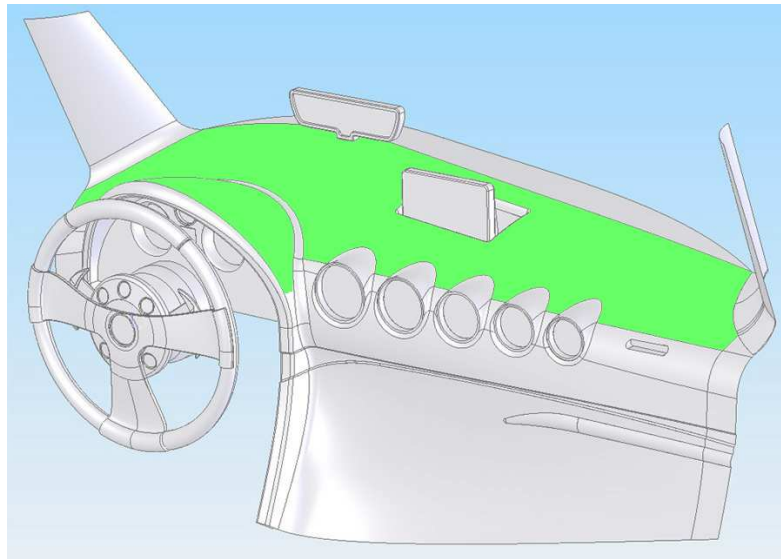

Figure 132: Correct placement of FMB630

24.6 Module Installation

- Module should not be seen or easily reached.
- Module should be firmly fixed to the surface or cables.
- Module cannot be fixed to heat emitting or moving parts.
- SIM card should be inserted in the module while the connector is plugged off (while module has no power).

25 CHANGE LOG

Nr.	Date	Version	Comments
1	2016-06-21	v1.01	Changed FM6320 interfaces list, I/O parameters list, all parameters ID, multiple parameters configuration format. Added descriptions to new configurator's tabs.
2	2016-06-21	V1.02	Changed KLN-200 and FM6320 connection to tachograph
3	2016-06-22	V1.03	Changed KLN-200 figure, fixed information about interfaces, changed accelerometer updating frequency, added some references, added examples of SMSevent and WeekTime configuration.
4	2016-07-26	V1.04	Added older tachograph version identification, changed scenarios functionality according to newest modifications.
5	2016-08-05	V1.05	Added one more supported tachograph version. Added all supported operating systems versions.
6	2016-08-29	V1.06	Added working time from internal battery, changed K line parameters configuration via sms explanation, corrected tables formatting, changed scenarios configurable parameters description.
7	2016-09-30	V1.07	Fixed speed based tracking, changed first page photo, changed interfaces list, changed modem version.
8	2016-10-05	V1.08	Added specifications and warnings for LVD.
9	2016-10-31	V1.09	Minor fixes regarding naming of figures and sms parameters table improvements;
10	2016-11-02	V1.10	Removed Kln-200 mounting description, added direct tachograph description;
11	2016-12-01	V1.11	Added CAN accessories, AutoCAN description, sleep mode, TCP link mode functionality, updated GNSS status tab, added TACHOCHECK sms description.
12	2016-12-13	V1.12	Fixed descriptions of TCP link modes, information about battery.
13	2017-01-07	V1.13	Added Stoneridge tachograph configuration description for K-Line data.
14	2017-03-23	V1.14	Added RJ45 connection description, RS485 description, J1939 and J1708 description, NTP description. Added SMS parameter IDs for tachograph. Added Web DDD functionality description. Added Dual Sim functionality and Sim installation instructions. Added Overvoltage protection information. Added GPRS command description.
15	2017-04-10	V1.15	Added iButton notification settings, Added description about webDDD and fixed SMS format for K-LINE and AutoCAN parameters
16	2017-04-13	V1.16	Added Jamming SMS configuration, Added iButton notification SMS configuration, Some minor changes in figures, Added LVCAN200, ALLCAN300 and Simple CAN description.
17	2017-04-21	V1.17	Updated configurable parameters table. Style changes, corrected references to figures and chapters.
18	2017-04-25	V1.18	Description and details about SMS events, Description and details about SMS events numbers, Description and details about Operator List and Black list, Jamming feature description, Excessive Idling feature description and Description about Trip feature added.
19	2017-04-28	V1.19	MVC300 Camera Solution with full functionality description added.
20	2017-05-25	V1.20	Updated LVCAN200 and ALLCAN300 description.
21	2017-06-22	V1.21	Updated getstatus SMS command, Updated camera functionality, added manual CAN2 sms parameters, Updated firmware update instructions, Updated eco driving/green driving scenario and some minor changes.
22	2017-07-11	V1.22	Added KLINE Tacho Timestamp command, Updated Operator list command description and Updated Banlist command description.
23	2017-08-18	V1.23	Manual CAN 1 and CAN2 SMS ID table are updated, SMS Format for configuring MCAN# updated, Added codec protocol description in Table 9, Updated Geofencing description, Introduced description about geozones and overspending and some figures are updated

24	2017-10-26	V1.24	SIM card insert scheme updated, Black list operator command added, Crash detection scenario added. GSM/GPS jacks descriptions edited. Total Odometer separated from Trip odometer. Trip odometer functionality description updated. New IO elements description added
25	2017-10-31	V1.25	Added LV -CAN200/ALLAN300 migration to 4 digit program nr. information