

GPS Vehicle tracker

(GPS+GSM+SMS/GPRS)

User Manual

(Version 2.2)



Please read this manual carefully before attempting installation and online activation. Pictures are for indication and illustration purposes only.

1. Accessories:



Please check the accessories before using. Pictures are for indication and illustration purposes only.

2. Features:

- GSM 850/900/1800/1900 Quad band
- Wide voltage (input range): 9-36V DC
- GPS continuous positioning, GPRS timing interval
- Check location via SMS
- Built-in vibration sensor, theftproof
- ACC ignition detection
- Tele-cutoff (petrol/ electricity) function
- SOS alarm and burglar alarm
- Voice monitoring function
- Alarm when the power supply is disconnected intentionally (with backup battery)
- Compatible with external connection through (serial port)
- Geo-fence

2.1 Red LED (power/working status)

LED Status	Meaning
Flashing (interval 0.1s)	Low battery indication
Continuously in bright state	Charging
Slow flashing(interval 0.2s)	Full charge
Continuously in dark state	Low battery / power off
Slow flashing(flash 0.1s after every 2s)	Working normally

2.2 Green LED(GSM status indicator)

LED Status	Meaning
Quick flashing (interval 0.1s)	GSM initialization
Slow flashing(flash 0.1s after every 2s)	Receive GSM signal normally
Continuously in bright state	GSM conversation/Start GPRS
Continuously in dark state	No GSM signal

2.3 Blue LED (GPS status indicator)

LED Status	Meaning
Flashing (interval 0.1s)	Searching GPS signal
Continuously in bright state	GPS located
Continuously in dark state	GPS not located

2.4 Ignition detection indication

Three (blue/red/green) LEDs are in cycling flashing

3. Interface introduction

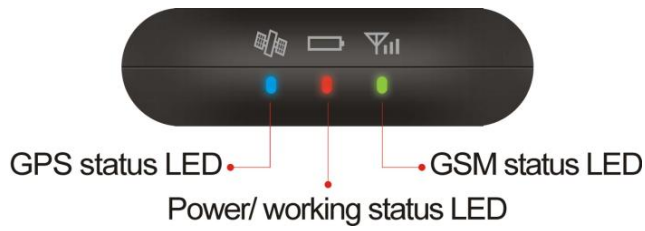
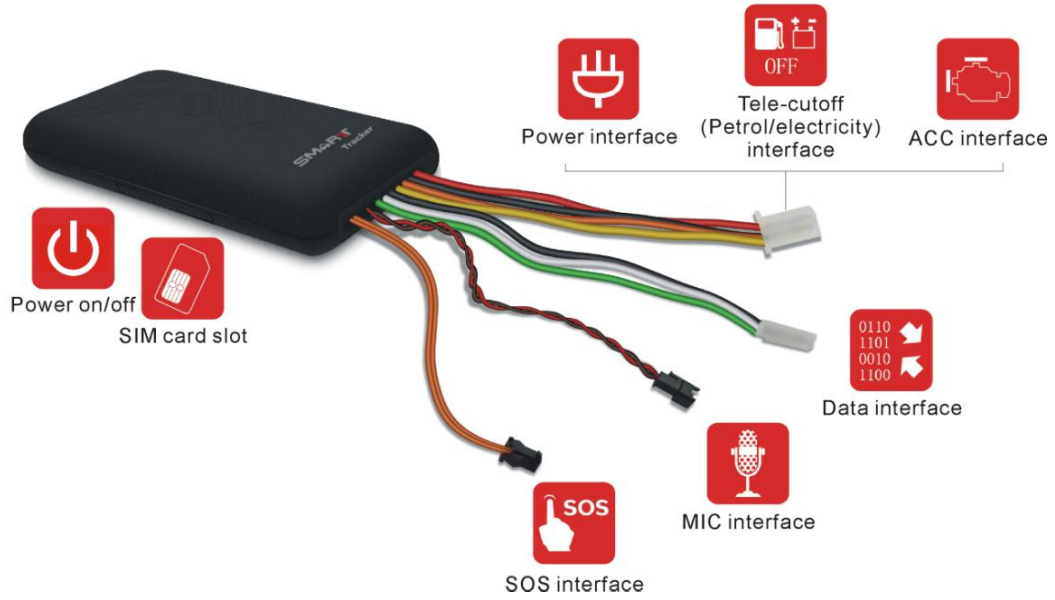

4. Method of installation

4.1. Preparation before installation

- 4.1.1 Open the packing box to check whether the type of device is correct and whether the accessories are included, or else please contact your distributor.
- 4.1.2 Choose SIM card: each device needs to insert a GSM SIM card. Please refer to the distributor's suggestions to choose the SIM card.
- 4.1.3 Installing SIM card: The SIM card slot is on the right side of device. Open the SIM card silicon seal, then insert the SIM card to the slot (do not insert the SIM card backwards). When the SIM card is ready you will hear a click. Or else please insert again and then replace the silicon seal.

Note:

Please use GSM network SIM card;
Power off before installing or removing the SIM card.
The SIM card used should be enabled for GPRS.
The SIM card used should be enabled for called ID.
If there is a power on password, or pin, please cancel it;
Ensure the SIM card can send and receive SMS.

4.2 Installation

The device installation is covert. Please refer installation to an auto electrical contractor.

NOTE:

- 4.2.1 To prevent theft of the device, it should be installed as covertly as possible. Covertly installation is suggested.
- 4.2.2 Avoid placing the device close to higher power electrical devices, such as reversing radar, anti-theft device or other vehicle communication equipment;
- 4.2.3 The device should be fixed into position with cable ties or wide double-side tape.
- 4.2.4 The device has built-in GSM antenna and GPS antenna. During installation, please make sure the receiving side face is up, with no metal object above the device to interfere with GPS reception. The following places are suggested for installation:

- shelter in the decorated board below the front windshield;
- shelter around the front instrument panel (non-metallic material face);
- in the decorated board below back windshield;

Notice: if the windshield is pasted with metal thermal-protective coating or heating coating, It may affect the receiving signal. In this case, please change the installation place.

4.3 Device outlet specification

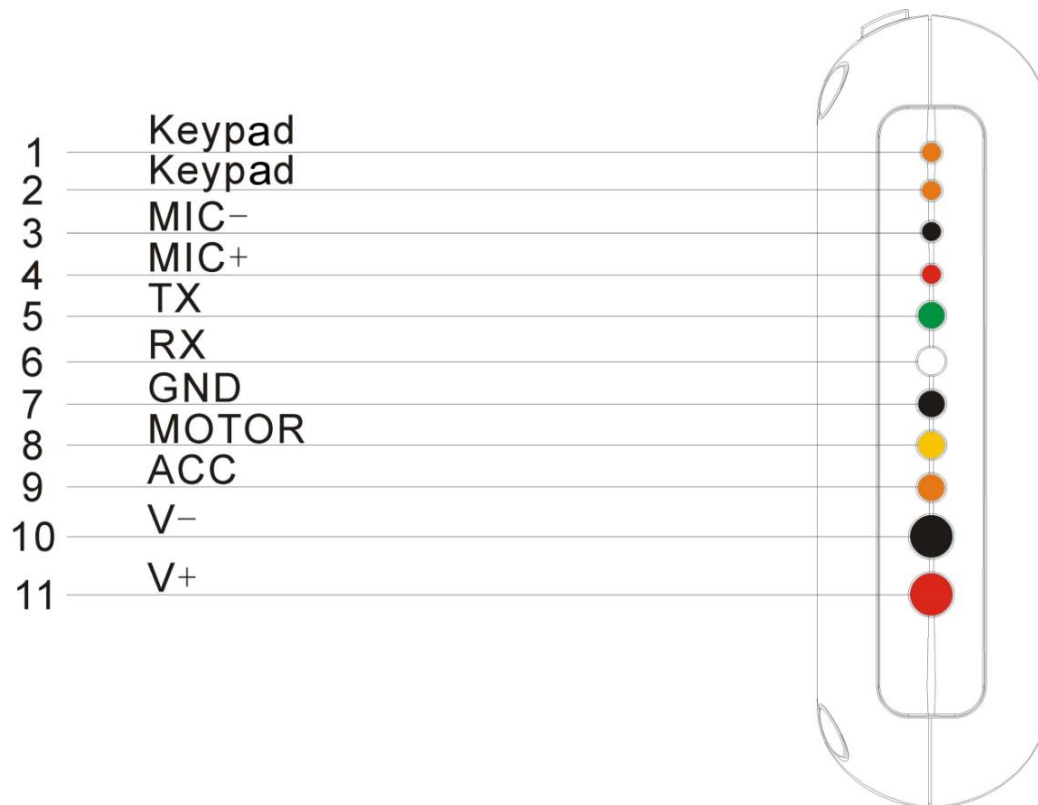

Line No.	Specification	Color	Instruction
1. 2	Keypad	Orange/ orange	Connect to SOS button
3. 4	MIC-,MIC+	Black/ red	Connect to Microphone
5	TX	Green	Sending data (TX)/backup
6	RX	White	Receiving data (RX)/backup
7	GND	Black	Ground wire
8	MOTOR	Yellow	Connect to relay control line
9	ACC	Orange	Connect to ACC ignition
10	V-	Black(thick)	Vehicle 12V/24V negative storage battery
11	V+	Red(thick)	Vehicle 12V/24V positive storage battery

Notes of the relay wiring

The relay wiring of pump: oil connectors of both ends are a fine white line (85) and a fine yellow line (86). The fine white line (85) is connected to vehicle positive power (+12V). The fine yellow line (86) is connected to the device relay control line.

Cut off the positive connection line of the pump; then connect in series to the relay N.C. contact (thick green line 87a) and the other end to relay COM contact ((thick green line 30).

4.4 Device wiring diagram

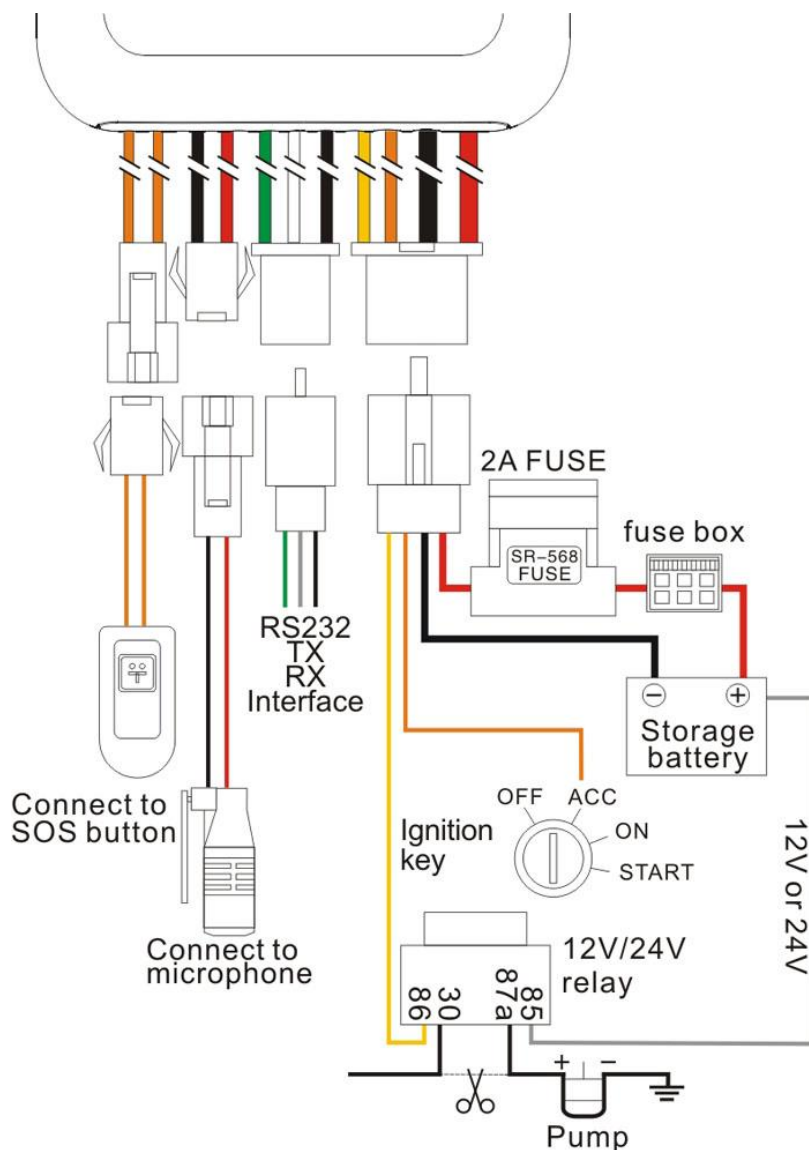

5. Cautions of device wiring

5.1 Power/ACC/Tele-cutoff (petrol/electricity) control line (4 pin)

5.1.1 The standard voltage is 9V-36V DC. Please use the power line which provided by the manufacturer. The red line is the positive. The black line is the negative. The negative should earth alone or link iron during installing. Do not connect it to other ground wire.

5.1.2 ACC line (orange) is connected to the ACC switch of the vehicle. Please make sure to connect the ACC line. The tracker will decide whether to enter ignition detection according to ACC status. If do not connect to ACC line, the device will enter ignition detection status. If the vehicle vibrates when moving, it will activate the vibration alarm. If there is no need for the theftproof function, connect the ACC line to the positive in parallel and keep high level.

5.1.3 Tele-cutoff (petrol/ electricity) control line (yellow) is connected to pin 86 of the Tele-cutoff (petrol/ electricity) relay (equal to the yellow line of the relay socket).

5.2 USB cable (3 pin)

Firmware updating interface/expanded function to reserve space.

5.3 MIC line (2 pin)

Externally connect to microphone for voice monitor function

5.4 SOS line (2 pin)

Externally connect to SOS switch for SOS function.

6. Parameter setting

The SMS command format is no case sensitive and it is divided by comma. There is a reply SMS after sending the command. If set successfully, there is a "ok" reply SMS; or else please set again.

The device will reply the corresponding information after sending the SMS command.

6.1 APN setting

After setting the APN of the sim card, device can be connected to the platform.

Please send the SMS command below:

APN command format: **APN,APN's Name#**

e.g: **APN,internet#**("internet" is the APN of carrier) the device will reply "OK" if setting successfully.

Note:The APN of some countries have user name and password, you may need to send SMS command as following:

APN command format: **APN,APN's Name,user name,password#**

e.g:**APN,internet,CLIENTE,AMENA#**

It will reply "OK" after set successfully.

6.2 DNS setting

To connect other platform, please send the two SMS commands below:

Command format:

In DNS way: ①**APN,APN's Name#**
②**SERVER,1,DNS,Port,0#**

Or in IP Way: ①**APN,APN's Name#**
②**SERVER,0,IP,port,0#**

e.g.:

In DNS way: ①**APN,internet#**
②**SERVER,1,www.cooaccess.net,8841,0#**

Or in IP Way: ①**APN,internet#**
②**SERVER,0,59.188.23.235,8841,0#**

It will reply "OK" after set successfully. Then the device will be connected to other platform.

6.3 ON /OFF GPRS

When you want to disable GPRS, you can sms command to the sim card number which used in the device.

Command format:

GPRS ON: GPRSON,1#

GPRS OFF: GPRSON,0#

It will reply "OK" after set successfully.

6.4 Add specific number

SMS command to the device to set the SOS number.

SOS,A,No.1,No.2,No.3#

"A" means to add new numbers, for example:

SOS,A,13510905991,13510905992,13510905993#

If there is only one SOS number, you can appoint a specific number as SOS number. And the null means no adding.

For example:

SOS,A,13510905991# means to set the first number as SOS number(After “A”, there is one comma)

SOS,A,,13510905992# means to set the second number as SOS number(After “A”, there are two commas)

SOS,A,,,13510905993# means to set the third number as SOS number(After “A”, there are three commas)

If set successfully, there is a “success” reply SMS.

6.5 Delete specific number

Before deleting specific number, please check its corresponding code. For the code, please SMS “**PARAM#**” to the device.

SMS command to the device to delete the number.

SOS,D,serial NO.1,serial NO.2,serial NO.3#

“D” means to delete the number, for example:

SOS,D,1# means to delete the first number

SOS,D,3# means to delete the third number

If you want to delete more than one numbers, you can send this command:

SOS,D,1,3# means to delete the first and third numbers.

If you forget serial number of the mobile number you want to delete, you can send this command:

SOS,D,mobile number# means to delete the mobile number directly.

For example:

SOS,D,13527852360# means to delete the 13527852360 directly.

After deleting the SOS number, it will receive “Delete number 135XXXXXXXXX success! specific number total 2” for successful deleting of the specific number.

6.6 Set the center number

If you want to cut off/restore oil by SMS command, you have to set a center number firstly. Only the center number can send the cut off/restore oil command to the device. You can set your own mobile number as center number.

The command for setting center number is:

CENTER,A,mobile number#

For example: **CENTER,A,15942703401#**

If set successfully, there is an “OK” reply message.

Note: Only the SOS number can be used to set center number successfully. Moreover, only the center number can send the cut off and restore oil commands to the device.

6.7 Delete the center number

Send a SMS command to the device to delete the center number.

The command is: **CENTER,D#**

For example: **CENTER,D#**

If set successfully, there is an "OK" reply SMS.

Note: Only the SOS number can be used to delete center number successfully.

6.8 Check parameter settings

Send a SMS command to the device to check the device's setting.

Command format: **PARAM#**

e.g.: PARAM#

Reply information:

IMEI: 35341903XXXXXXX // IMEI number of the device//

GPRS Interval:10; //GPS data uploading Interval, the time ranges from 10-18000s, default as 10s //

TIMESET:20; //the GPS working time when ACC is OFF, the time range from 1-999mins(default as 20 min)//

SOS Number: 1. 135xxxxxxx

2. 136xxxxxxx

3. 137xxxxxxx //maximum three SOS numbers used for

alarm //Center Number: 15942703401 //only one center number used for cutting off and restoring oil command//

Sensor time interval:10,180; //sensor detecting time, default as 10s; vibratio

alarm delay, default as 180s; the time ranges from10-300s//

Sensor alarm time interval:10; //sensor alarm time interval, the time ranges from 1-60mins; default as 10mins//

TimeZone:E,8,0; //set time zone; default as E8//

It contains IMEI number/ GPRS Interval/TIMESET/SOS/CENTER

number/Sensor time interval/Sensor alarm time Interval/Time Zone

6.9 Check GPRS parameters

SMS command format: **GPRSSET#**

e.g.: GPRSSET#

Reply message:

GPRS:ON //GPRS on/off status//

APN:CMNET,0,0.0.0.0,;, //APN setting information//

Server:1,egt06.szdatasource.com,8841,0; //platform information//

URL:http://maps.google.com/maps?q=; //preset web link setting information //

6.10 GPRS time interval

The default GPRS time sending interval is 10s which means the device will

upload positioning data to the platform server every 10s. Users can modify GPRS time sending interval by SMS "**TIMER,time(second)#**". The time ranges from 10-18000s

For example: **TIMER,10#**

It means the device will upload data to the server every 10s.

6.11 Sensor alarm time setting

When the vehicle power is off and ACC is in low-level, if ACC is off over 10 minutes, the device will enter sensor alarm state. In this case, if the vehicle vibrates for a few times, it will activate the vibration alarm system. If the vehicle battery is still not on (ACC is in low level) after 3 minutes, the device will start vibration alarm.

SMS format: "**DEFENSE,TIME(minutes)#**" The time ranges from 1 to 60 mins.

For example: **DEFENSE,15#**. It means when ACC is in low level for 15mins, it will enter sensor alarm status (vehicle power is off)

NOTE: 1. Preset SOS numbers when send SMS alarm messages and calls.

2. If there is no need for vibration alarm, please SMS command **SENSOR,0#** to close it.

6.12 Restore to factory setting

SMS command format: "**FACTORY#**" to set all parameter to default factory value. Once received "OK", it succeeds.

6.13 Reboot device

When there is something wrong with the link of GPRS, e.g., The parameter setting of the device is correct, but you can't track the car on the platform. At this moment you can send a command to the device to reboot the device.

The format is: **RESET#**

After receiving this command, the device will reboot after 1mins.

7. Operation of device

7.1 Power on/ Power off

Power on: Once insert a valid SIM card and connect all the wires, turn on the device, then Power LED will flash first, During signal searching process, GSM and GPS LED will flash. Once GPS LED keeps solid light, it means the device has been located and it starts to work.

Power off: Just turn off the power switch.

The device will begin to upload positioning data to server once inserting a valid

SIM card and power on. During the working time, it can upload data to server every 10 seconds.

7.2 Check location

7.2.1 Via SMS

7.2.1.1 Send SMS command “**POSITION**” to the SIM number of GT06. If the device succeed to get the address, it will reply a location Google Map link.

```
<Date                               Time:10-11-23                               23:42:51>  
http://maps.google.com/maps?q=N22.571490,E113.877103
```

7.2.1.2 Send SMS command “**WHERE#**”, to the SIM number of GT06. The terminal will send a location message automatically. You can get the address. If the device does not search any information of location, it will send “No data” to the cell phone.

Example:

```
Lat:N22.571285,Lon:E113.877115,Course:42.20,Speed:0.0740,DateTime:10-11-23 22:28:51
```

7.2.1.3 Send SMS command “**URL#**”, to the SIM number of GT06. The device will send a location Google Map link. If the device does not search any information of location, it will send “No data” to the cell phone.

Example:

```
<Date                               Time:                               10-11-23                               23:42:51>  
http://maps.google.com/maps?q=N22.571490,E113.877103
```

7.2.2 Via platform

Go to the platform website offered by dealers to check your vehicle’s location.

7.3 SOS alarm

In emergent case, press SOS for 3s to activate SOS alarm. Then the device will send SOS SMS to preset specific numbers and then dial the numbers in circles until the call is through. At the meantime, the device will upload SOS alarm data to the server. And it will send:

```
SOS Alarm! <DateTime:11-06-17 14:53:06>,  
http://maps.google.com/maps?q=N22576713,E113.916585
```

Note: The specific numbers should be preset, just refer to 6.4

7.4 Wire cut-off alarm

When the electricity supply of device is cut off, it will activate cut-off alarm. In this case, the device will send related SMS to the specific numbers and dial the

numbers in circles. If nobody answers, the call just keeps 3 loops at most. At the meantime, the device will upload SOS alarm data to the server. And it will send:

Cut Power! <Date Time:11-06-17

14:53:06>,http://maps.google.com/maps?q=N22576713,E113.916585

Note: The specific numbers should be preset, just refer to 6.4

7.5 Low battery alarm

When the device is only working with battery, once the internal voltage of battery is less than 3.7V, device will send low battery alarm sms to specific number and alarm on platform.

Low battery alarm sms content example: "Attention!!!battery too low, please charge." Which means the battery is too low, to inform user charging it in time.

Note: The specific numbers should be preset, just refer to 6.4

7.6 Vibration alarm

When vehicle power is off, ACC status is also low, and if the lead time of low ACC is more than 10 minutes (settable), device will activate security alarm. When the security alarm is on, once the vehicle vibrates for several times, the alarm will be activated, in the later 3 minutes, vehicle power is still off (ACC status is low, device will start alarm). At this time, it will send alarm SMS to SOS specific number, and dial the SOS specific number in cycle until through. If nobody answers, the call just keeps 3 loops at most. The tracking platform will also receive vibration alarm message.

e.g.: Sensor Alarm!<Date Time:11-06-17 14:53:06>, http://maps.google.com/maps?q=N22576713,E113.916585

Note: The specific numbers should be preset, just refer to 6.4

Send SMS command "[SENSOR,0#](#)" to turn off vibration alarm.

7.7 Voice monitoring

When the special number cellphone dial device, ringing for 10 seconds, it will enter voice monitoring status. At this time, caller can monitoring the sound in vehicle.

Incoming call from non special number will not activate voice monitoring function.

Note: To realize this function, the specific numbers should be preset, just refer to 6.4.The SIM card put into the device should be equipped with caller identification.

7.8 Oil cut-off

7.8.1. Via platform

Send oil cut-off command on platform. To make sure the security of vehicle, tracker can only indicate to cut off oil when GPS is in valid position status, and the speed is less than 20KM/H or in static. It needs password and platform account password is needed when sending oil cut off command.

7.8.2. Via SMS

Firstly, you should set a center number. Only center number can send the command to the device to cut off and restore oil.

The format is: **RELAY,1#**

After the command is carried out, it will reply "Cut off the fuel supply: Success! Speed:0 Km/h". If the command didn't carry out, it will reply the reason about fail to carry out.

Note: To ensure the safety of the driver and the car, this command is valid only under two conditions: the GPS is located; the speed is less than 20km/h

7.9 Restoring Oil

7.9.1. Via platform

When the alarm is off, sending recover oil commands manually. Device will restore oil supplying, and vehicle will work normally again.

Platform account password is required when sending oil cut off command.

7.9.2. Via SMS

Only center number can send the command to the device to restore oil.

The format is: **RELAY,0#**

After the command is carried out, it will receive "Restore fuel supply:Success!"

8. Web based tracking online activation

The GPRS web based tracking platform allows real time tracking with the latest Google maps. There is also a playback feature that allows you to view where the vehicle has been for up to 30 days in the past making it ideal for fleet management.

9. Trouble shooting

9.1. After installing it in the first time, if device can not get connected with platform server, at this time it is "logged off" status in platform.

Please check the installation of device:

- 1) Check whether the connection of power-line is correct, please do not connect it with the car control line.
- 2) Check whether SIM card is installed correctly, please refer to the installation manual;
- 3) Check whether the power switch is toggled to "ON", the switch is in the left

of the SIM card's slot.

- 4) Whether ACC ignition cable is connected, please turn on the ACC with key after it is connected.
- 5) Check the LEDs' status. In normal working status, the red LED is in solid bright or flashing; green LED and blue LED are both in solid bright.
- 6) Check whether GPS is located, if not, please drive to the open areas for positioning.

9.2 If it is "offline" status in platform:

First of all, check the three LEDs' status. If it is not convenient to check that, please check the SIM card status :

- 1) Call the SIM card number of the device to check whether you can get through;
- 2) Check whether the vehicle is in no GSM area, such as basement;
- 3) Check the GSM/GPS disconnection area, whether it is all disconnected or few of them disconnected, to make sure whether it is the fault of operator's internet.
- 4) Check whether your SIM card charge is overdue;
- 5) Check whether the SIM card supports GPRS;
- 6) Check the parameter setup, whether the device IMEI number, GPRS sending interval is correct;

9.3 If the device's GPS function is normal, but can not locate for a long time, please check whether the installation setup of device is correct:

- 1) Please make sure the GPS antenna face is up;
- 2) Please make sure there is no electromagnetic wave- absorbent object (metal) above the device, especially the thermal-protective coating on the windshield, it may affect the GPS reception of the device;

9.4 If GPS can not receive the signals normally (there is high building around to interfere with GPS reception), please drive to the open areas for positioning. Generally, it needs 1-2 minutes to receive the first coordinates.

9.5 If GSM can not receive the signals normally, please check whether SIM card is installed correctly or there is no GSM signal at the location you are, such as basement parking, please drive to a place covered by GSM signal reception.

9.6 When cellphone with special number receives tele- cutoff alarm sms, please make sure whether it is illegal wire cutoff, or the FUSE on power line is blown. If the FUSE in it is blown, please contact your distributor to exchange with the same model FUSE, after the internal trouble is shoot, it can be power on to work again.

Warranty card of GPS Vehicle tracker

Special statement:

1. Specifications of this product subject to change without further notice.
2. Any change about the appearance and color is subject to the real object.
3. Warranty card applies to the product with the IMEI number listed below.
4. Please keep this card safely for after-sale service, as well as your receipt.
5. Refer to the table below for the warranty reference.

This card is the basic certificate for warranty, please fill it carefully and keep it safely.

Name		Phone number	
Address			
model		IMEI number	
Date		Invoice number	
Sales unit name			
Sales unit address			
Sales unit phone number			
	<p>1. Main engine is guaranteed for one year for non-human damage since the date of purchase.</p> <p>2. The situations listed below are not in the scope of warranty, the user has to pay maintenance cost:</p> <p style="margin-left: 20px;">(1) exceed the warranty period;</p> <p style="margin-left: 20px;">(2) disassemble or maintain without authorization;</p> <p style="margin-left: 20px;">(3) immersion, break or burn of circuit board;</p> <p style="margin-left: 20px;">(4) damages from improper installation, use, maintenance or storage;</p> <p style="margin-left: 20px;">(5) damages of shell, lens or internal antenna;</p> <p style="margin-left: 20px;">(6) IMEI number is torn or faded;</p> <p style="margin-left: 20px;">(7) warranty certificate is inconsistent with product model, or the certificate is altered;</p> <p style="margin-left: 20px;">(8) the damages due to force majeure</p>		

Maintenance records

Record one			
Maintenance unit		Date	
Fault description			
Maintenance status			
IMEI number		Serviceman	

Record two			
Maintenance unit		Date	
Fault description			
Maintenance status			
IMEI number		IMEI number	